

Single Pack SC15CLX.2 208-230V 60Hz CSCR

Single pack code number: **195B4163**

Position	Title	Code	Amount
1	Compressor SC15CLX.2	104L2897	1
2	SC starting device (550mm)	117-7039	1
3	Cord relief	103N1004	1
4	Cover	103N2008	1
5	Bolt joint for one compressor M6 ø16mm	118-1917	1

Secop GmbH • Lise-Meitner-Straße 29 • 24941 Flensburg, Germany • Tel: +49 461 4941 0 • www.secop.com

Secop accepts no responsibility for possible errors in catalogs, brochures, and other printed material. Secop reserves the right to alter its products without notice. This also applies to products already on order provided that such alterations can be made without subsequent changes being necessary to specifications already agreed. All trademarks in this material are the property of the respective companies. Secop and the Secop logotype are trademarks of Secop GmbH. All rights reserved.

Model

Designation	SC15CLX.2	208-230V/60Hz 1~	Sales code:	104L2897
-------------	------------------	------------------	-------------	-----------------

Compressor design

Oil type	Polyolester	Refrigerant(s)	R404A, R507
Oil viscosity	32cSt	Displacement	15,28cm ³ / 0,93cu.in
Oil quantity	544cm ³ / 18,4fl.oz	Compressors on pallet	80
Refr. charge - tech. limit	1300g / 45,9oz		
Free gas volume comp.	1510cm ³ / 51,1fl.oz		
Weight	13,8kg / 30,4lbs		
Motor protection	1# internal		
Winding resistance main	3,4Ω (at 25°C)		
Winding resistance aux	14,4Ω (at 25°C)		
Max. winding temp.	125°C / 257°F		
Max. discharge temp.	130°C / 266°F		



General - Configurations with SC15CLX.2

	Conf. 1	Conf. 2
Motorconfiguration	CSCR	CSCR
Power supply (nominal)	208-230V/60Hz	208-230V/60Hz
Number of phases	1	1
Voltage range	187-254V	187-254V
Approvals	UL, KC	UL
Starting torque	HST	HST
Note	- / -	

Applications with SC15CLX.2

	Conf. 1	Conf. 2
Refrigerant	R404A	R452A
Application	LBP	LBP
System cooling	fan 3m/s	fan 3m/s
Hot gas defrost	OK	OK
Long interval pull down	OK	OK

Electrical data - Configurations with SC15CLX.2

	Conf. 1	Conf. 2
Starting device type	relay	relay
Run capacitor	10μF	10μF
Start capacitor	80μF	80μF
LRA (locked rotor amps / 4s)	23,4A	23,4A
RLA (rated load amps / 1s)	4,3A	4,3A
Cut in current	23,4A	23,4A
IP class	21	21

Model

Designation	SC15CLX.2	208-230V/60Hz 1~	Sales code:	104L2897
-------------	------------------	------------------	-------------	-----------------

Compressor dimensions

Housing	A Height	219mm / 8,62in
	B Height	213mm / 8,39in
	C Length shell	239mm / 9,41in
	D Length w. cover	255mm / 10,04in
	E Width	151mm / 5,94in

Connectors		Suction	Discharge	Process
		X	Y	Z
Diameter	[mm]	øi 9,54-9,72	øi 6,41-6,59	øi 6,41-6,59
(i:inside, o:outside)	[in]	øi 0,38-0,38	øi 0,25-0,26	øi 0,25-0,26
Material		copper	copper	copper
Horizontal angle	±2°	37°	37°	143°
Vertical angle	±2°	30°	0°	150°
Position l/h/w	[mm]	107/193/55	115/110/63	-107/193/55
	[in]	4,2/7,6/2,2	4,5/4,3/2,5	-4,2/7,6/2,2
Straight tube l.	[mm]	12	12	12
	[in]	0,5	0,5	0,5



Compressor fixation



Baseplate	[mm]	[inch]
BI	204	8.03
BW	150	5.9
øE	ø 9.7	ø 0.38
Large holes		
LI	165	6.5
LW	101.6	4
øL	ø 19	ø 0.75
Small holes		
SI	170	6.7
SW	70	2.76
øS	ø 16	ø 0.63
QI	127	5
Qw	127	5

Bolt joint

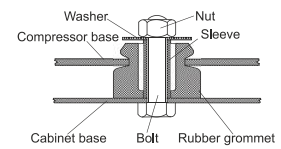

Snap-on



Mounting accessories	one comp.	multi pack
Bolt joint M6 ø16mm	118-1917	118-1918
Bolt joint ø1/4" ø16mm	118-1946	
Bolt joint ø1/4" ø19mm	118-1949	
Snap-on ø7,3 ø16mm	118-1947	118-1919

Application notes

LRA value on compressor label and datasheet may differ due to different test conditions for UL approval.

Model

Designation	SC15CLX.2	208-230V/60Hz	Conf. 1	Sales code:	104L2897
-------------	------------------	----------------------	----------------	-------------	-----------------

Configuration

Motorconfiguration	CSCR	
Power supply (nominal)	208-230V/60Hz 1~	
Refrigerant	R404A	
Application	LBP	
Voltage range	187-254V	
Starting torque	HST	
Approvals	UL	SA3693
	KC	

Electrical accessories / wiring diagram

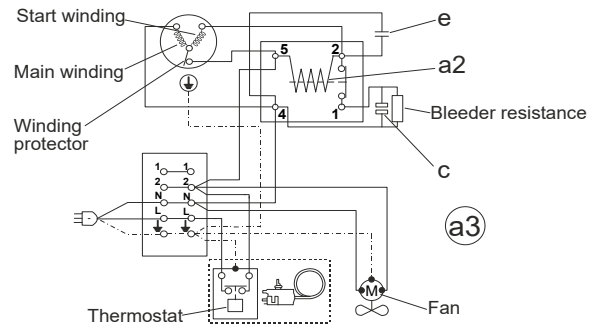
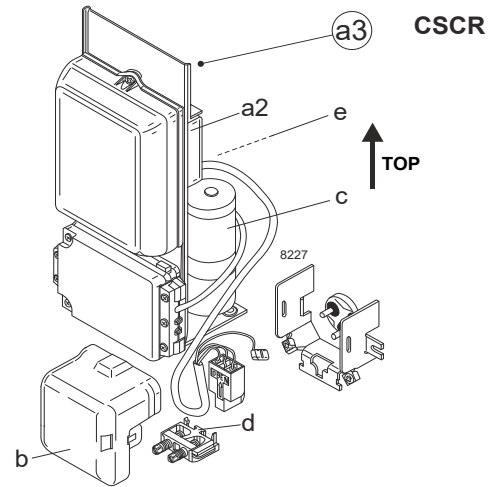

Ambient temperatures / system cooling

Ambient temperature min.:	10°C / 50°F
Ambient temperature max.:	38°C / 101°F

System cooling (n/a: outside limits)			
T ambient	LBP	MBP	HBP
32°C / 90°F	fan 3m/s	n/a	n/a
38°C / 100°F	fan 3m/s	n/a	n/a
43°C / 110°F	n/a	n/a	n/a

Operation pressure range

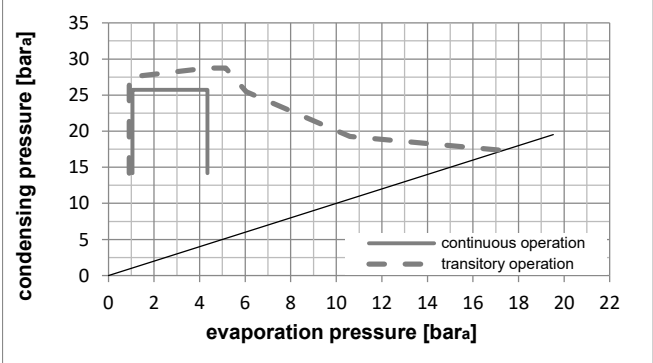
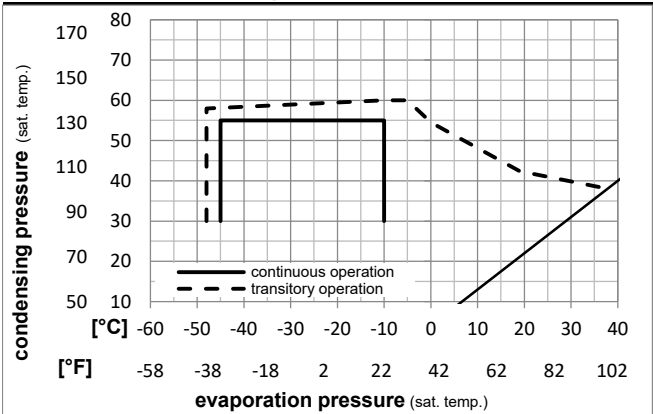

Components

a3	SC starter kit (550mm)	117-7039
b	plastic cover	103N2008
d	cord relief	103N1004

Alternative components

a3	SC starter kit (1000mm)	117-7043
----	-------------------------	----------

Model

Designation **SC15CLX.2 208-230V/60Hz** Conf. 1 Sales code: **104L2897**

Optimization + standard conditions

230V/60Hz, CSCR, fan 3m/s, UL, KC

Evaporating pressure (saturation temperature)				Condensing pressure (saturation temperature)				Power consumption				ASHRAE LBP		
Return gas temp.				Liquid temp.				Current consumption					Ref. mass flow	
Cooling capacity				COP	EER		P1	I	m					
pe	pc	RGT	Tliq	[W]	[Btu/h]	[kcal/h]	[W/W]	[Btu/Wh]	[kcal/Wh]	[W]	[A]		[kg/h]	
[°C]	-23,3	54,4	32,2	32,2	880,0	3005	757,4	1,33	4,54	1,14	662,7	3,09	20,51	ASHRAE LBP
[°F]	-10	130	90	90										
[°C]	-25	55	32	55	592,4	2023	509,8	0,93	3,18	0,80	636,3	2,96	18,51	cecomaf LBP
[°F]	-13	131	89,6	131										
[°C]	-35	40	20	40	478,1	1633	411,4	1,03	3,50	0,88	466,1	2,22	12,99	EN12900 LBP
[°F]	-31	104	68	104										
[°C]	-23,3	48,9	4,44	48,9	664,9	2271	572,2	1,03	3,51	0,89	646,5	3,04	23,54	ARI540 LBP
[°F]	-10	120	40	120										
[°C]	-23,3	40,6	32,2	32,2	1017,4	3475	875,6	1,63	5,57	1,40	624,1	2,95	23,71	AHAM LBP
[°F]	-10	105	90	90										
[°C]	-35	45	32	45	436,6	1491	375,8	0,93	3,18	0,80	468,6	2,22	11,67	opt
[°F]	-31	113	89,6	113										

Performance tables

230V/60Hz, CSCR, fan 3m/s, UL, KC

	pe	Cooling capacity			COP	EER		P1	I	m	
	[°C]	[°F]	[W]	[Btu/h]	[kcal/h]	[W/W]	[Btu/Wh]	[kcal/Wh]	[W]	[A]	[kg/h]
[°C / °F]	-45	-49	193,6	661	166,6	0,59	2,03	0,51	325,5	1,60	5,14
cond. pressure	-34,4	-30	452,7	1546	389,6	0,95	3,25	0,82	476,4	2,26	12,11
pc= 45/113	-28,9	-20	631,1	2155	543,1	1,14	3,88	0,98	555,1	2,62	16,96
return gas temp.	-23,3	-10	844,2	2883	726,5	1,33	4,54	1,14	635,6	3,01	22,81
RGT= 32/90	-20,6	-5	965,3	3297	830,7	1,43	4,87	1,23	677,2	3,20	26,17
liquid temp	-15	5	1239,2	4232	1066,5	1,62	5,54	1,40	764,0	3,61	33,85
Tliq= 45/113	-10	14	1525,2	5209	1312,6	1,80	6,15	1,55	847,6	3,98	42,00
[°C / °F]	-45	-49	92,8	317	79,8	0,31	1,07	0,27	296,0	1,46	2,85
cond. pressure	-34,4	-30	317,1	1083	272,9	0,66	2,26	0,57	478,3	2,23	9,81
pc= 55/131	-28,9	-20	469,0	1602	403,6	0,82	2,80	0,71	571,2	2,65	14,59
return gas temp	-23,3	-10	650,0	2220	559,4	0,98	3,34	0,84	664,4	3,09	20,36
RGT= 32/90	-20,6	-5	752,9	2571	648,0	1,06	3,61	0,91	711,6	3,31	23,67
liquid temp	-15	5	986,3	3369	848,9	1,22	4,17	1,05	808,6	3,77	31,28
Tliq= 55/131	-10	14	1231,0	4204	1059,4	1,37	4,67	1,18	900,0	4,20	39,41

Model

Designation **SC15CLX.2** 208-230V/60Hz Conf. 2 Sales code: **104L2897**

Configuration

Motorconfiguration **CSCR**
 Power supply (nominal) **208-230V/60Hz 1~**
 Refrigerant **R452A**
 Application **LBP**
 Voltage range **187-254V**
 Starting torque **HST**
 Approvals **UL SA3693**

Electrical accessories / wiring diagram

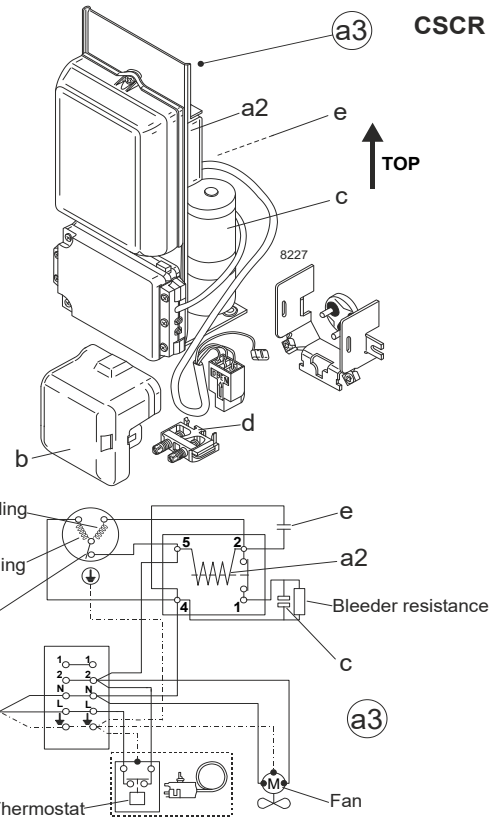

Ambient temperatures / system cooling

Ambient temperature min.: **10°C / 50°F**
 Ambient temperature max.: **38°C / 101°F**

System cooling (n/a: outside limits)			
T ambient	LBP	MBP	HBP
32°C / 90°F	fan 3m/s	n/a	n/a
38°C / 100°F	fan 3m/s	n/a	n/a
43°C / 110°F	n/a	n/a	n/a

Operation pressure range

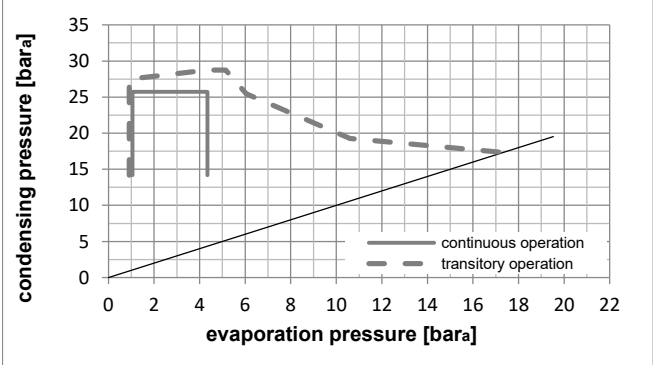
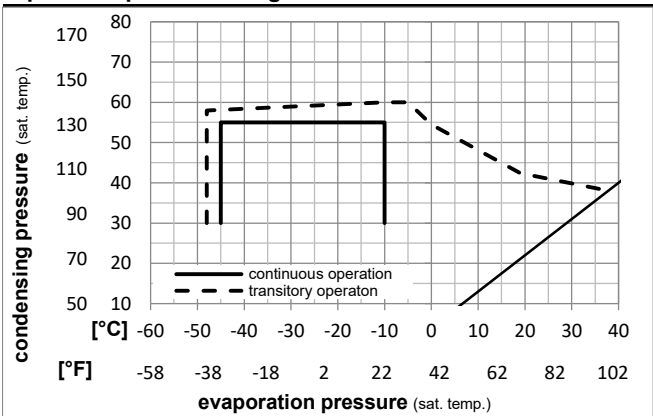

Components

- a3 SC starter kit (550mm) 117-7039
- b plastic cover 103N2008
- d cord relief 103N1004

Alternative components

- a3 SC starter kit (1000mm) 117-7043

Model

Designation **SC15CLX.2 208-230V/60Hz** Conf. **2** Sales code: **104L2897**

Optimization + standard conditions

230V/60Hz, CSCR, fan 3m/s, UL

Evaporating pressure (saturation temperature)														
Condensing pressure (saturation temperature)														
Return gas temp.														
Liquid temp.														
Cooling capacity														
COP														
EER														
Power consumption														
Current consumption														
Ref. mass flow														
	pe	pc	RGT	Tliq	[W]	[Btu/h]	[kcal/h]	[W/W]	[Btu/Wh]	[kcal/Wh]	P1	I	m	
[°C]	[°C]	[°C]	[°C]	[°C]	[W]	[Btu/h]	[kcal/h]	[W/W]	[Btu/Wh]	[kcal/Wh]	[W]	[A]	[kg/h]	
[°F]	-23,3	54,4	32,2	32,2	803,4	2744	691,4	1,30	4,44	1,12	618,5	2,91	19,31	ASHRAE LBP
[°F]	-10	130	90	90										
[°C]	-25	55	32	55	545,1	1862	469,1	0,92	3,15	0,79	591,8	2,79	17,35	cecomaf LBP
[°F]	-13	131	89,6	131										
[°C]	-35	40	20	40	430,4	1470	370,4	1,00	3,42	0,86	430,0	2,06	12,02	EN12900 LBP
[°F]	-31	104	68	104										
[°C]	-23,3	48,9	4,44	48,9	616,8	2107	530,9	1,02	3,48	0,88	604,9	2,84	22,17	ARI540 LBP
[°F]	-10	120	40	120										
[°C]	-23,3	40,6	32,2	32,2	935,3	3194	804,9	1,60	5,46	1,38	585,3	2,76	22,48	AHAM LBP
[°F]	-10	105	90	90										
[°C]	-35	45	32	45	391,8	1338	337,1	0,91	3,11	0,78	430,6	2,06	10,75	opt
[°F]	-31	113	89,6	113										

Performance tables

230V/60Hz, CSCR, fan 3m/s, UL

	pe		Cooling capacity			COP			EER		P1	I	m
	[°C]	[°F]	[W]	[Btu/h]	[kcal/h]	[W/W]	[Btu/Wh]	[kcal/Wh]	[W]	[A]	[kg/h]		
[°C / °F]	-45	-49	163,7	559	140,9	0,56	1,92	0,48	291,1	1,43	4,47		
cond. pressure	-34,4	-30	406,9	1390	350,2	0,93	3,17	0,80	438,3	2,10	11,17		
pc= 45/113	-28,9	-20	575,8	1966	495,5	1,12	3,81	0,96	515,7	2,44	15,87		
return gas temp.	-23,3	-10	779,0	2661	670,5	1,31	4,47	1,13	595,4	2,80	21,59		
RGT= 32/90	-20,6	-5	895,1	3057	770,3	1,41	4,80	1,21	636,7	2,99	24,87		
liquid temp	-15	5	1158,9	3958	997,4	1,60	5,47	1,38	723,3	3,38	32,42		
Tliq= 45/113	-10	14	1435,9	4904	1235,7	1,78	6,08	1,53	807,1	3,76	40,46		
[°C / °F]	-45	-49	72,2	247	62,2	0,28	0,96	0,24	256,6	1,28	2,26		
cond. pressure	-34,4	-30	282,9	966	243,5	0,65	2,22	0,56	435,4	2,08	8,93		
pc= 55/131	-28,9	-20	427,1	1459	367,6	0,81	2,77	0,70	527,2	2,50	13,54		
return gas temp	-23,3	-10	600,5	2051	516,8	0,97	3,31	0,83	619,8	2,91	19,14		
RGT= 32/90	-20,6	-5	699,6	2389	602,1	1,05	3,58	0,90	667,0	3,12	22,38		
liquid temp	-15	5	925,8	3162	796,8	1,21	4,14	1,04	764,3	3,56	29,84		
Tliq= 55/131	-10	14	1164,5	3977	1002,2	1,36	4,64	1,17	856,4	3,98	37,85		

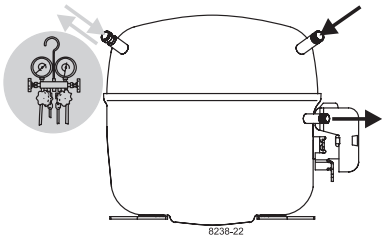

SC Compressors





SC Compressors

Service/Repair – R290



8545



Secop accepts no responsibility for possible errors in catalogs, brochures, and other printed material. Secop reserves the right to alter its products without notice. This also applies to products already on order provided that such alterations can be made without subsequent changes being necessary to specifications already agreed. All trademarks in this material are the property of the respective companies. Secop and the Secop logotype are trademarks of Secop GmbH. All rights reserved. www.secop.com