

## Single Pack SCE15MNX 208-230V 60Hz CSCR

Single pack code number: **195B4328**

Position	Title	Code	Amount
1	Compressor SCE15MNX	104H8579	1
2	SC starting device (550mm)	117-7808	1
3	Bolt joint for one compressor   M6   ø16mm	118-1917	1

**Secop GmbH** • Lise-Meitner-Straße 29 • 24941 Flensburg, Germany • Tel: +49 461 4941 0 • [www.secop.com](http://www.secop.com)

Secop accepts no responsibility for possible errors in catalogs, brochures, and other printed material. Secop reserves the right to alter its products without notice. This also applies to products already on order provided that such alterations can be made without subsequent changes being necessary to specifications already agreed. All trademarks in this material are the property of the respective companies. Secop and the Secop logotype are trademarks of Secop GmbH. All rights reserved.

## Model

Designation	<b>SCE15MNX</b>	208-230V/60Hz 1~	Sales code:	<b>104H8579</b>
-------------	-----------------	------------------	-------------	-----------------

## Compressor design

Oil type	Polyolester	Refrigerant(s)	<b>R290</b>
Oil viscosity	32cSt	Displacement	15,28cm <sup>3</sup> / 0,93cu.in
Oil quantity	541cm <sup>3</sup> / 18,3fl.oz	Compressors on pallet	80
Refr. charge - tech. limit	450g / 15,9oz		
Free gas volume comp.	1460cm <sup>3</sup> / 49,4fl.oz		
Weight	14,2kg / 31,3lbs		
Motor protection	external		
Winding resistance main	3,12Ω (at 25°C)		
Winding resistance aux	11,25Ω (at 25°C)		
Max. winding temp.	125°C / 257°F		
Max. discharge temp.	130°C / 266°F		



## General - Configurations with SCE15MNX

	<b>Conf. 1</b>
Motorconfiguration	CSCR
Power supply (nominal)	208-230V/60Hz
Number of phases	1
Voltage range	187-253V
Approvals	UL
Starting torque	HST
Note	Protector and cover are included and pre-assembled to compressor.

## Applications with SCE15MNX

	<b>Conf. 1</b>
Refrigerant	R290
Application	MBP
System cooling	fan 3m/s
Hot gas defrost	OK
Long interval pull down	OK

## Electrical data - Configurations with SCE15MNX

	<b>Conf. 1</b>
Starting device type	relay
Run capacitor	10μF
Start capacitor	80μF
LRA (locked rotor amps / 4s/ U(N))	24,22A
RLA (rated load amps / 1s/ U(N))	3,85A
Cut in current (U(N))	24,22A

## Model

Designation

**SCE15MNX**

208-230V/60Hz 1~

Sales code:

**104H8579**

## Compressor dimensions

Housing	A Height	219mm / 8,62in
	B Height	213mm / 8,39in
	C Length shell	218mm / 8,58in
	D Length w. cover	255mm / 10,04in
	E Width	151mm / 5,94in

Connectors		Suction	Discharge	Process
		X	Y	Z
Diameter	[mm]	øi 9,54-9,72	øi 6,41-6,59	øi 6,41-6,59
	(i:inside, o:outside) [in]	øi 0,38-0,38	øi 0,25-0,26	øi 0,25-0,26
Material		copper	copper	copper
Horizontal angle	±2°	37°	37°	143°
Vertical angle	±2°	30°	0°	150°
Position l/h/w	[mm]	107/193/55	115/110/63	-107/193/55
	[in]	4,2/7,6/2,2	4,5/4,3/2,5	-4,2/7,6/2,2
Straight tube l.	[mm]	12	12	12
	[in]	0,5	0,5	0,5



## Compressor fixation

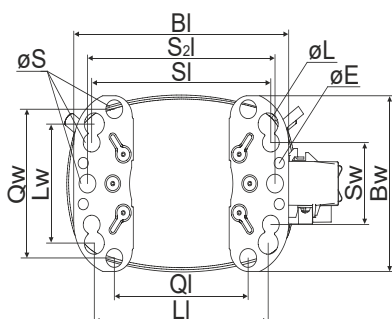

Baseplate	[mm]	[inch]
BI	204	8.03
Bw	150	5.9
øE	ø 9.7	ø 0.38
Large holes	[mm]	[inch]
LI	165	6.5
Lw	101.6	4
øL	ø 19	ø 0.75
Small holes	[mm]	[inch]
SI	170	6.7
Sw	70	2.76
øS	ø 16	ø 0.63
QI	127	5
Qw	127	5

### Bolt joint

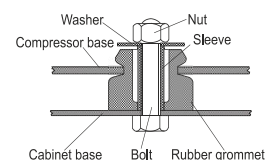

### Snap-on

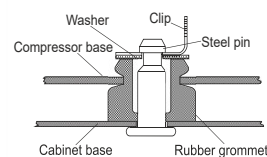

## Mounting accessories

	one comp.	multi pack
Bolt joint   M6   ø16mm	118-1917	118-1918
Bolt joint   ø1/4"   ø16mm	118-1946	
Bolt joint   ø1/4"   ø19mm	118-1949	
Snap-on   ø7,3   ø16mm	118-1947	118-1919

## Application notes

Provision for PE Grounding is located at the PE Stamp on the compressor

## Model

Designation	<b>SCE15MNX</b>	<b>208-230V/60Hz</b>	<b>Conf. 1</b>	Sales code:	<b>104H8579</b>
-------------	-----------------	----------------------	----------------	-------------	-----------------

## Configuration

Motor configuration	CSCR
Power supply (nominal)	208-230V/60Hz 1~
Refrigerant	R290
Application	MBP
Voltage range	187-253V
Starting torque	HST
Approvals	UL

## Electrical accessories / wiring diagram



## Ambient/ machine room temperatures minimum /maximum

Ambient temperature range:	10 - 43°C / 50 - 110°F
Machine room temperature range:	10 - 48°C / 50 - 119°F
Compressor cooling:	fan 3m/s

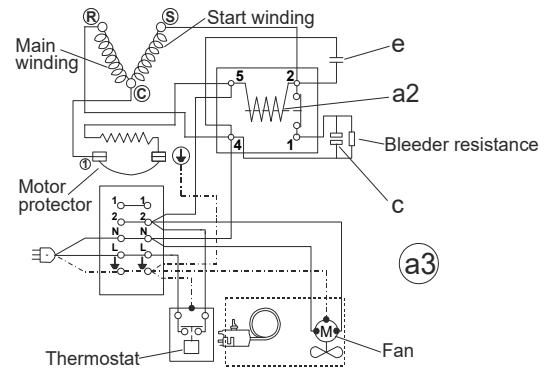

## Operation pressure range

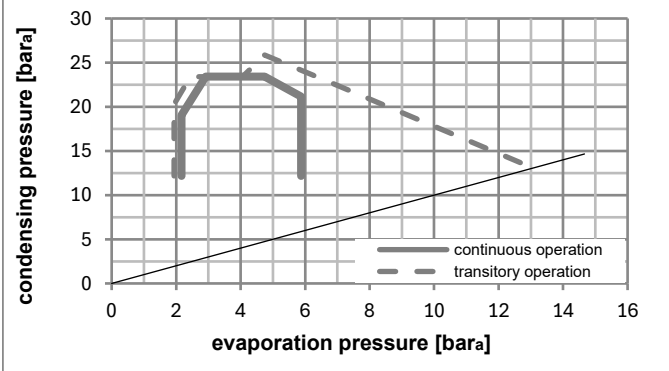
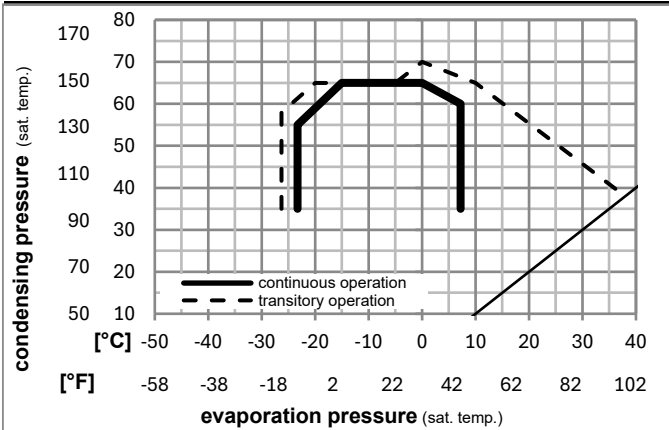

## Components (protector (f)+ holder (h)+ cover (b): pre assembled)

a3	SC starter kit (550mm)	117-7808
f / h	protector assy. (T1116)	117U8002
b	plastic cover + clamp	117U1021

## Alternative comp.

a2	potential relay (RVA2AM3R A89)	117-7601
e	run capacitor (10μF, 6.3mm)	117-7121
c	start capacitor (80μF)	117U5373

## Noise emission

Operation pressures:	pe: -10°C / 14°F
	pc: 45°C / 113°F
Motor speed appr.:	3500rpm
Lw(A):	60dB(A)

### Model

Designation **SCE15MNX** **208-230V/60Hz** Conf. 1 Sales code: **104H8579**

### Optimization + standard conditions

R290, 230V/60Hz, CSCR, fan 3m/s, UL

		Evaporating pressure (saturation temperature)				Cooling capacity			COP	EER		Power consumption					
		Condensing pressure (saturation temperature)		Return gas temp.	Liquid temp.	[W]	[Btu/h]	[kcal/h]	[W/W]	[Btu/Wh]	[kcal/Wh]	P1	I	Ref. mass flow			
[°C]	[°F]	pe	pc	RGT	Tliq							[W]	[A]	[kg/h]			
-7	20	54	130	35	95	46	115	1554,0	5307	1337,4	2,25	7,70	1,94	689,5	3,12	17,73	ASHRAE MBP
-10	14	55	131	32	90	55	131	1223,3	4178	1052,7	1,87	6,40	1,61	652,9	2,95	15,47	cecomaf MBP
-10	14	45	113	20	68	45	113	1376,1	4700	1184,3	2,21	7,56	1,91	621,3	2,75	16,90	EN12900 MBP
-7	20	49	120	18	65	49	120	1466,5	5008	1262,1	2,19	7,49	1,89	668,8	3,00	19,04	ARI540 MBP
-10	14	45	113	32	90	45	113	1432,6	4892	1232,9	2,31	7,87	1,98	621,3	2,75	16,39	opt
-25	-13	45	113	32	90	45	113	719,9	2459	619,6	1,57	5,35	1,35	459,8	2,07	8,12	opt

### Performance tables

R290, 230V/60Hz, CSCR, fan 3m/s, UL

	pe		Cooling capacity			COP	EER		P1	I	m
	[°C]	[°F]	[W]	[Btu/h]	[kcal/h]	[W/W]	[Btu/Wh]	[kcal/Wh]	[W]	[A]	[kg/h]
[°C / °F]	-25	-13	719,9	2459	619,6	1,57	5,35	1,35	459,8	2,07	8,12
cond. pressure	-23	-10	789,5	2696	679,4	1,65	5,63	1,42	478,9	2,15	8,92
pc= 45/113	-15	5	1171,2	4000	1008,0	2,05	7,00	1,76	571,7	2,54	13,33
return gas temp.	-9	15	1463,3	4997	1259,3	2,34	7,98	2,01	626,3	2,77	16,75
RGT= 32/90	-4	25	1791,7	6119	1541,9	2,67	9,13	2,30	670,4	2,95	20,66
liquid temp	0	32	2046,0	6987	1760,8	2,95	10,09	2,54	692,8	3,05	23,73
Tliq= 45/113	7,2	45	2578,4	8806	2219,0	3,63	12,39	3,12	710,6	3,13	30,29
[°C / °F]	-25	-13	571,7	1952	492,0	1,24	4,23	1,07	461,5	2,09	7,12
cond. pressure	-23	-10	634,7	2168	546,2	1,31	4,49	1,13	483,0	2,18	7,91
pc= 55/131	-15	5	982,8	3356	845,8	1,66	5,68	1,43	591,1	2,68	12,36
return gas temp	-9	15	1251,7	4275	1077,2	1,90	6,48	1,63	659,5	2,98	15,84
RGT= 32/90	-4	25	1556,1	5314	1339,2	2,16	7,38	1,86	720,1	3,25	19,86
liquid temp	0	32	1793,2	6124	1543,3	2,37	8,10	2,04	755,9	3,41	23,03
Tliq= 55/131	7,2	45	2292,9	7831	1973,3	2,86	9,76	2,46	802,2	3,61	29,87



# SCE Compressors

## (External Protector)



	S	C	R
ENGLISH	Black	Brown	Blue or grey
DEUTSCH	Schwarz	Braun	Blau od. grau
FRANÇAIS	Noir	Marron	Bleu ou gris
ESPAÑOL	Negro	Marrón	Azul o gris
ITALIANO	Nero	Marrone	Blu o grigio
NEDERLANDS	Zwart	Bruin	Blauw of grijs
РУССКИЙ	Чёрный	Коричневый	Синий или серый
中文	黑色	棕色	蓝色或灰色

	S	C	R
ENGLISH	Black	Brown	Blue or grey
DEUTSCH	Schwarz	Braun	Blau od. grau
FRANÇAIS	Noir	Marron	Bleu ou gris
ESPAÑOL	Negro	Marrón	Azul o gris
ITALIANO	Nero	Marrone	Blu o grigio
NEDERLANDS	Zwart	Bruin	Blauw of grijs
РУССКИЙ	Чёрный	Коричневый	Синий или серый
中文	黑色	棕色	蓝色或灰色



# SCE Compressors (External Protector)



## Service/Repair – R290



8545



## Brazing on Suction Connectors (Direct Intake)



**! max. 350°C/662°F !**  
**at socket**  
brazing solder: phosphor (LP7) or silver

8882

Refer to Product Bulletin:  
**Brazing on Suction Connectors**  
**(SCE Compressors with Direct Suction Intake)**

Secop accepts no responsibility for possible errors in catalogs, brochures, and other printed material. Secop reserves the right to alter its products without notice. This also applies to products already on order provided that such alterations can be made without subsequential changes being necessary to specifications already agreed. All trademarks in this material are the property of the respective companies. Secop and the Secop logotype are trademarks of Secop GmbH. All rights reserved. [www.secop.com](http://www.secop.com)