

Single Pack SC18MLX.3 220-240V 50Hz CSCR

Single pack code number: **195B4330**

Position	Title	Code	Amount
1	Compressor SC18MLX.3	104L2146	1
2	SC starting device (550mm)	117-7027	1
3	Cord relief	103N1004	1
4	Cover	103N2009	1
5	Bolt joint for one compressor M6 ø16mm	118-1917	1

Secop GmbH • Lise-Meitner-Straße 29 • 24941 Flensburg, Germany • Tel: +49 461 4941 0 • www.secop.com

Secop accepts no responsibility for possible errors in catalogs, brochures, and other printed material. Secop reserves the right to alter its products without notice. This also applies to products already on order provided that such alterations can be made without subsequent changes being necessary to specifications already agreed. All trademarks in this material are the property of the respective companies. Secop and the Secop logotype are trademarks of Secop GmbH. All rights reserved.

Model

Designation	SC18MLX.3	220-240V/50Hz 1~	Sales code:	104L2146
-------------	------------------	-------------------------	-------------	-----------------

Compressor design

Oil type	Polyolester	Refrigerant(s)	R404A, R452A, R507
Oil viscosity	32cST	Displacement	17,68cm ³ / 1,08cu.in
Oil quantity	550cm ³ / 18,6fl.oz	Compressors on pallet	80
Refr. charge - tech. limit	1300g / 45,9oz		
Free gas volume comp.	1460cm ³ / 49,4fl.oz		
Weight	14kg / 30,9lbs		
Motor protection	1# internal		
Winding resistance main	3,4Ω (at 25°C)		
Winding resistance aux	14,4Ω (at 25°C)		
Max. winding temp.	125°C / 257°F		
Max. discharge temp.	130°C / 266°F		



General - Configurations with SC18MLX.3

	Conf. 1	Conf. 2	Conf. 3	Conf. 4
Motorconfiguration	CSCR	CSCR	CSCR	CSCR
Power supply (nominal)	220-240V/50Hz	220-240V/50Hz	220-240V/50Hz	220-240V/50Hz
Number of phases	1	1	1	1
Voltage range	198-254V	198-254V	198-254V	198-254V
Approvals	CCC, EAC, VDE	CCC, EAC, VDE		
Starting torque	HST	HST	HST	HST
Note	- / -			

Applications with SC18MLX.3

	Conf. 1	Conf. 2	Conf. 3	Conf. 4
Refrigerant	R404A	R452A	R448A	R449A
Application	MBP	MBP	MBP	MBP
System cooling	fan 3m/s	fan 3m/s	fan 3m/s	fan 3m/s
Hot gas defrost	OK	OK	OK	OK
Long interval pull down	OK	OK	OK	OK

Electrical data - Configurations with SC18MLX.3

	Conf. 1	Conf. 2	Conf. 3	Conf. 4
Starting device type	relay	relay	relay	relay
Run capacitor	10μF	10μF	10μF	10μF
Start capacitor	80μF	80μF	80μF	80μF
LRA (locked rotor amps / 4s)	23,4A	23,4A	23,4A	23,4A
RLA (rated load amps / 1s)	4,3A	4,3A	4,3A	4,3A
Cut in current	23,4A	23,4A	23,4A	23,4A

Model

Designation	SC18MLX.3	220-240V/50Hz 1~	Sales code:	104L2146
-------------	------------------	------------------	-------------	-----------------

Compressor dimensions

Housing	A Height	219mm / 8,62in
	B Height	213mm / 8,39in
	C Length shell	239mm / 9,41in
	D Length w. cover	255mm / 10,04in
	E Width	151mm / 5,94in

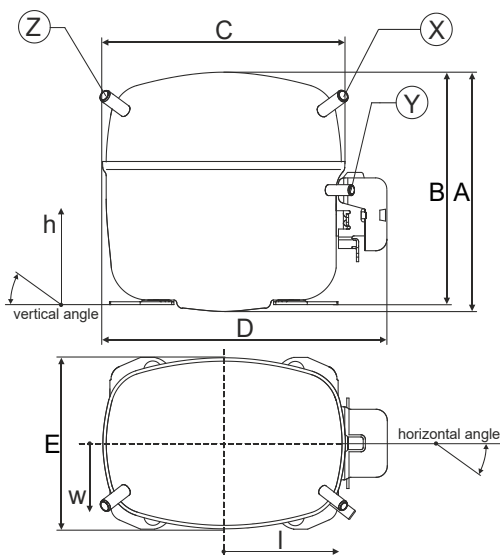

Connectors	Suction		Discharge		Process	
	X		Y		Z	
Diameter [mm]	øi 10,11-10,29		øi 6,11-6,29		øi 6,11-6,29	
(i:inside, o:outside) [in]	øi 0,4-0,41		øi 0,24-0,25		øi 0,24-0,25	
Material	copper		copper		copper	
Horizontal angle ±2°	37°		37°		143°	
Vertical angle ±2°	30°		0°		150°	
Position l/h/w [mm]	107/193/55		115/110/63		-107/193/55	
[in]	4,2/7,6/2,2		4,5/4,3/2,5		-4,2/7,6/2,2	
Straight tube l. [mm]	12		12		12	
[in]	0,5		0,5		0,5	

Compressor fixation

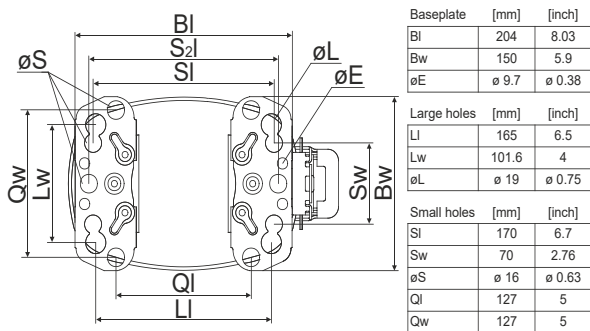

Bolt joint

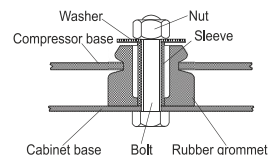

Snap-on

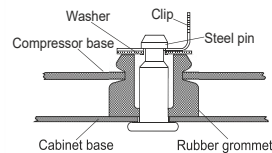

Mounting accessories	one comp.	multi pack
Bolt joint M6 ø16mm	118-1917	118-1918
Bolt joint ø1/4" ø16mm	118-1946	
Bolt joint ø1/4" ø19mm	118-1949	
Snap-on ø7,3 ø16mm	118-1947	118-1919

Application notes

Provision for PE Grounding is located at the PE Stamp on the compressor

Model

Designation	SC18MLX.3	220-240V/50Hz	Conf. 1	Sales code:	104L2146
-------------	------------------	----------------------	---------	-------------	-----------------

Configuration

Motorconfiguration	CSCR
Power supply (nominal)	220-240V/50Hz 1~
Refrigerant	R404A
Application	MBP
Voltage range	198-254V
Starting torque	HST
Approvals	CCC
	EAC
	VDE

Electrical accessories / wiring diagram

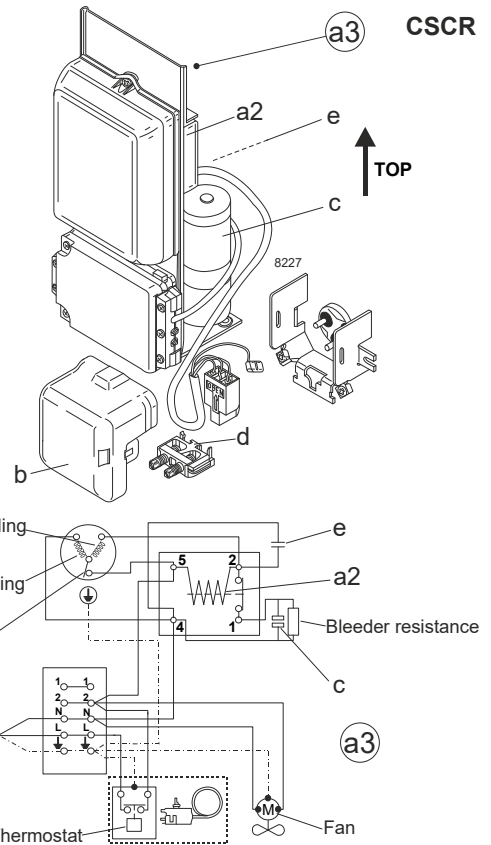

Ambient/ machine room temperatures minimum /maximum

Ambient temperature range: 10 - 38°C / 50 - 101°F

Machine room temperature range: 10 - 43°C / 50 - 110°F

Compressor cooling: fan 3m/s

Operation Limits

Operation pressure range

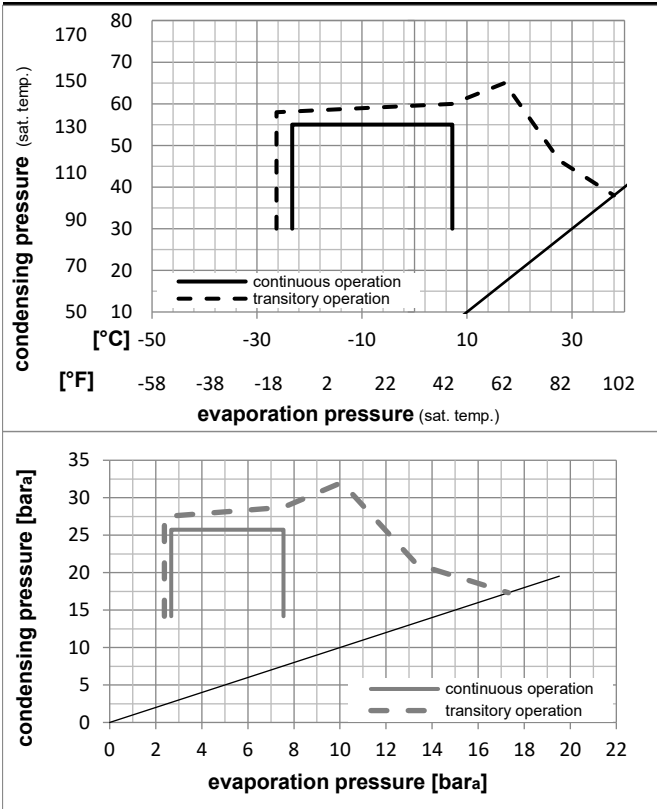

Components

a3	SC starter kit (550mm)	117-7027
b	plastic cover	103N2009
d	cord relief	103N1004

Alternative components

a3	SC starter kit (1000mm)	117-7040
a3	SC starter kit (650mm)	117-7046
c	start capacitor (80µF)	117U5373
e	run capacitor (10µF, 6.3mm)	117-7112

Model

Designation **SC18MLX.3** **220-240V/50Hz** Conf. 1 Sales code: **104L2146**

Optimization + standard conditions

R404A, 220V/50Hz, CSCR, fan 3m/s, CCC, EAC, VDE

Evaporating pressure (saturation temperature)				Condensing pressure (saturation temperature)			Return gas temp.			Liquid temp.			Cooling capacity			COP	EER	Power consumption			Ref. mass flow m	ASHRAE MBP
pe	pc	RGT	Tliq	[W]	[Btu/h]	[kcal/h]	[W/W]	[Btu/Wh]	[kcal/Wh]	P1	I	[kg/h]										
[°C]	[°C]	[°C]	[°C]	[W]	[Btu/h]	[kcal/h]	[W/W]	[Btu/Wh]	[kcal/Wh]	[W]	[A]	[kg/h]										
-7	54	35	46	1684,7	5753	1449,8	1,67	5,70	1,44	1008,5	4,61	46,35	ASHRAE MBP									
[°F]	[°F]	[°F]	[°F]																			
-10	55	32	55	1260,1	4304	1084,5	1,32	4,51	1,14	954,0	4,42	40,34	cecomaf MBP									
[°F]	[°F]	[°F]	[°F]																			
-10	45	20	45	1467,5	5012	1263,0	1,67	5,71	1,44	878,1	4,40	44,20	EN12900 MBP									
[°F]	[°F]	[°F]	[°F]																			
-7	49	18	49	1530,1	5225	1316,8	1,60	5,45	1,37	958,8	4,61	50,00	ARI540 MBP									
[°F]	[°F]	[°F]	[°F]																			
-10	45	32	45	1557,5	5319	1340,4	1,77	6,06	1,53	878,1	4,40	42,89	opt									
[°F]	[°F]	[°F]	[°F]																			
-25	45	32	45	810,8	2769	697,8	1,24	4,25	1,07	652,2	3,78	21,87	opt									
[°F]	[°F]	[°F]	[°F]																			

Performance tables

R404A, 220V/50Hz, CSCR, fan 3m/s, CCC, EAC, VDE

	pe		Cooling capacity			COP	EER		P1	I	m
	[°C]	[°F]	[W]	[Btu/h]	[kcal/h]	[W/W]	[Btu/Wh]	[kcal/Wh]	[W]	[A]	[kg/h]
[°C / °F]	-23	-10	877,2	2996	754,9	1,29	4,42	1,11	677,8	3,85	23,71
cond. pressure	-20	-4	1018,4	3478	876,4	1,40	4,78	1,20	727,4	3,98	27,63
pc= 45/113	-15	5	1265,8	4323	1089,3	1,58	5,38	1,36	802,9	4,18	34,58
return gas temp.	-10	14	1557,5	5319	1340,4	1,77	6,06	1,53	878,1	4,40	42,89
RGT= 32/90	-5	23	1898,0	6482	1633,4	1,99	6,81	1,72	952,4	4,63	52,76
liquid temp	0	32	2291,8	7827	1972,3	2,24	7,63	1,92	1025,3	4,87	64,43
Tliq= 45/113	7,2	45	2961,6	10114	2548,8	2,63	8,98	2,26	1126,9	5,24	84,93
[°C / °F]	-23	-10	710,7	2427	611,6	0,99	3,37	0,85	719,5	3,75	22,26
cond. pressure	-20	-4	823,1	2811	708,4	1,06	3,62	0,91	776,7	3,91	25,90
pc= 55/131	-15	5	1022,3	3491	879,8	1,18	4,04	1,02	864,8	4,16	32,42
return gas temp	-10	14	1260,1	4304	1084,5	1,32	4,51	1,14	954,0	4,42	40,34
RGT= 32/90	-5	23	1541,1	5263	1326,2	1,48	5,04	1,27	1043,8	4,70	49,88
liquid temp	0	32	1869,6	6385	1609,0	1,65	5,63	1,42	1133,6	4,98	61,31
Tliq= 55/131	7,2	45	2435,4	8317	2095,9	1,93	6,59	1,66	1262,1	5,42	81,73

Model

Designation	SC18MLX.3	220-240V/50Hz	Conf. 2	Sales code:	104L2146
-------------	------------------	----------------------	---------	-------------	-----------------

Configuration

Motorconfiguration	CSCR
Power supply (nominal)	220-240V/50Hz 1~
Refrigerant	R452A
Application	MBP
Voltage range	198-254V
Starting torque	HST
Approvals	CCC
	EAC
	VDE

Electrical accessories / wiring diagram

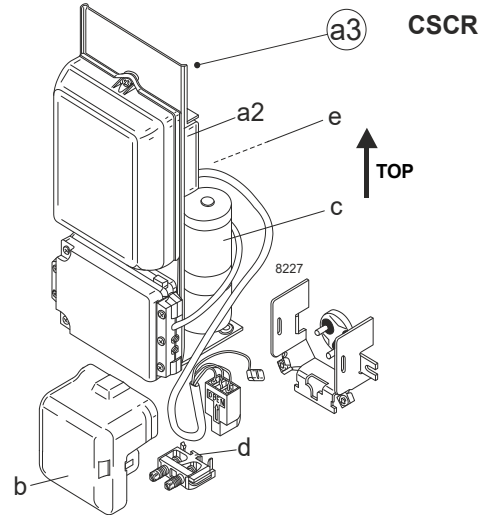

Ambient/ machine room temperatures minimum /maximum

Ambient temperature range: 10 - 38°C / 50 - 101°F

Machine room temperature range: 10 - 43°C / 50 - 110°F

Compressor cooling: fan 3m/s

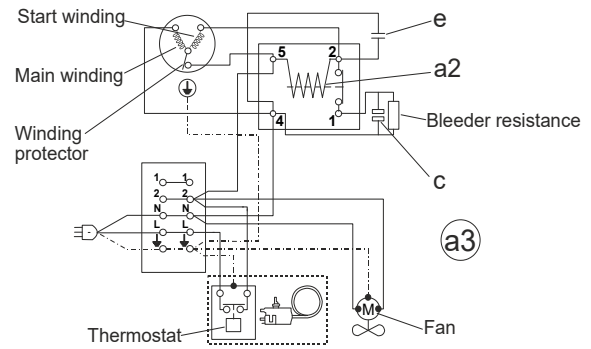

Operation Limits

Operation pressure range

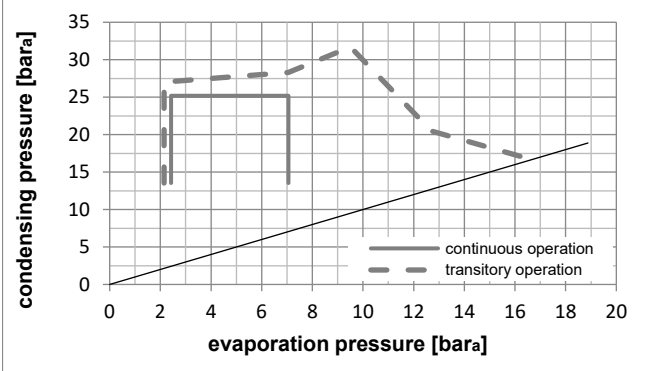
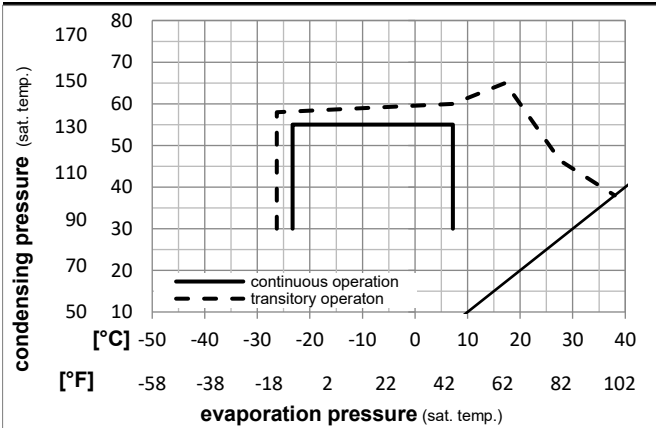

Components

a3	SC starter kit (550mm)	117-7027
b	plastic cover	103N2009
d	cord relief	103N1004

Alternative components

a3	SC starter kit (1000mm)	117-7040
a3	SC starter kit (650mm)	117-7046
c	start capacitor (80μF)	117U5373
e	run capacitor (10μF, 6.3mm)	117-7112

Model

Designation	SC18MLX.3	220-240V/50Hz	Conf. 2	Sales code:	104L2146
-------------	------------------	----------------------	----------------	-------------	-----------------

Optimization + standard conditions

R452A, 220V/50Hz, CSCR, fan 3m/s, CCC, EAC, VDE

		Evaporating pressure (saturation temperature)				Condensing pressure (saturation temperature)					Power consumption						
		Return gas temp.				Liquid temp.					Current consumption			Ref. mass flow			
		Cooling capacity				COP					EER	P1	I	m			
		pe	pc	RGT	Tliq	[W]	[Btu/h]	[kcal/h]	[W/W]	[Btu/Wh]	[kcal/Wh]	[W]	[A]	[kg/h]			
[°C]	[°F]																
-7	20	54	130	35	95	46	115	1592,9	5440	1370,9	1,66	5,66	1,43	960,7	4,50	44,81	ASHRAE MBP
-10	14	55	131	32	90	55	131	1193,3	4075	1027,0	1,32	4,50	1,14	904,7	4,25	38,79	cecomaf MBP
-10	14	45	113	20	68	45	113	1385,1	4731	1192,1	1,66	5,67	1,43	834,3	4,01	42,56	EN12900 MBP
-7	20	49	120	18	65	49	120	1453,7	4965	1251,1	1,59	5,43	1,37	914,0	4,31	48,23	ARI540 MBP
-10	14	45	113	32	90	45	113	1467,8	5013	1263,2	1,76	6,01	1,51	834,3	4,01	41,36	opt
-25	-13	45	113	32	90	45	113	746,0	2548	642,0	1,23	4,19	1,06	608,3	3,08	20,64	opt

Performance tables

R452A, 220V/50Hz, CSCR, fan 3m/s, CCC, EAC, VDE

	pe		Cooling capacity			COP	EER		P1	I	m
	[°C]	[°F]	[W]	[Btu/h]	[kcal/h]	[W/W]	[Btu/Wh]	[kcal/Wh]	[W]	[A]	[kg/h]
[°C / °F]	-23	-10	809,7	2765	696,8	1,28	4,36	1,10	633,6	3,18	22,44
cond. pressure	-20	-4	945,6	3229	813,8	1,38	4,73	1,19	683,1	3,38	26,29
pc= 45/113	-15	5	1184,7	4046	1019,5	1,56	5,33	1,34	758,5	3,69	33,14
return gas temp.	-10	14	1467,8	5013	1263,2	1,76	6,01	1,51	834,3	4,01	41,36
RGT= 32/90	-5	23	1799,6	6146	1548,7	1,98	6,75	1,70	909,9	4,33	51,14
liquid temp	0	32	2184,6	7461	1880,1	2,22	7,58	1,91	984,9	4,66	62,70
Tliq= 45/113	7,2	45	2841,9	9706	2445,8	2,61	8,90	2,24	1090,8	5,13	83,02
[°C / °F]	-23	-10	655,8	2240	564,4	0,98	3,35	0,84	668,9	3,25	20,91
cond. pressure	-20	-4	765,2	2613	658,6	1,05	3,60	0,91	726,1	3,48	24,49
pc= 55/131	-15	5	959,9	3278	826,1	1,18	4,02	1,01	814,5	3,85	30,94
return gas temp	-10	14	1193,3	4075	1027,0	1,32	4,50	1,14	904,7	4,25	38,79
RGT= 32/90	-5	23	1470,2	5021	1265,3	1,48	5,04	1,27	996,2	4,66	48,26
liquid temp	0	32	1795,2	6131	1545,0	1,65	5,63	1,42	1088,7	5,09	59,61
Tliq= 55/131	7,2	45	2356,8	8049	2028,3	1,93	6,58	1,66	1222,6	5,73	79,88

Model

Designation	SC18MLX.3	220-240V/50Hz	Conf. 3	Sales code:	104L2146
-------------	------------------	----------------------	----------------	-------------	-----------------

Configuration

Motorconfiguration	CSCR
Power supply (nominal)	220-240V/50Hz 1~
Refrigerant	R448A
Application	MBP
Voltage range	198-254V
Starting torque	HST
Approvals	

Electrical accessories / wiring diagram



Ambient/ machine room temperatures minimum /maximum

Ambient temperature range: 10 - 38°C / 50 - 101°F

Machine room temperature range: 10 - 43°C / 50 - 110°F

Compressor cooling: fan 3m/s

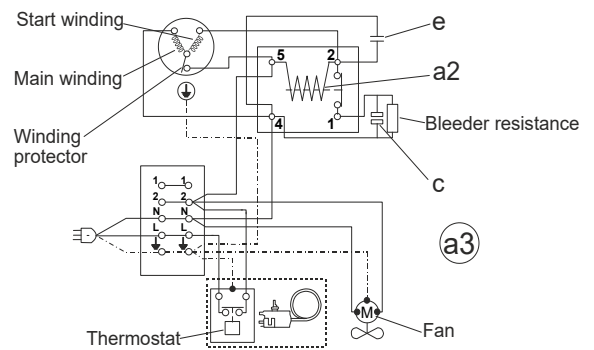

Operation Limits

Operation pressure range

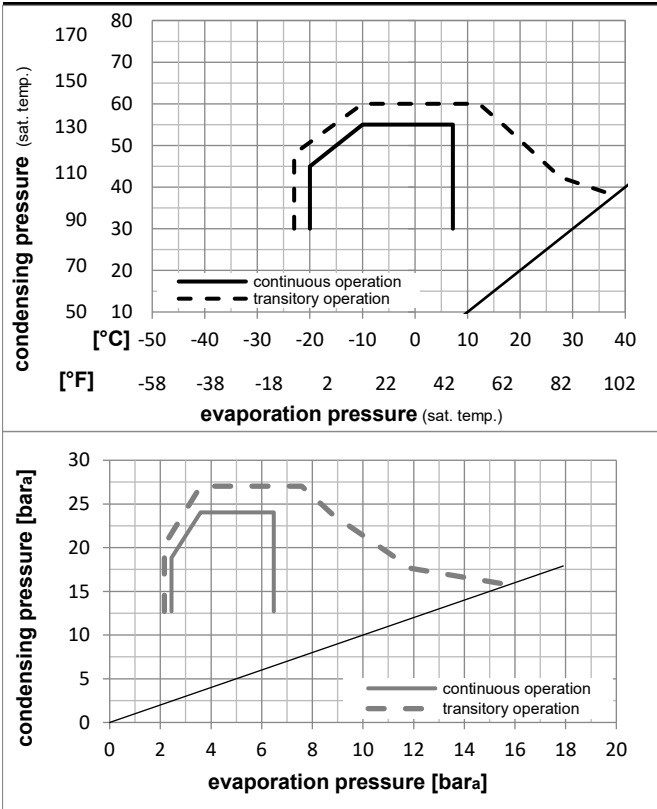

Components

a3	SC starter kit (550mm)	117-7027
b	plastic cover	103N2009
d	cord relief	103N1004

Alternative components

a3	SC starter kit (1000mm)	117-7040
a3	SC starter kit (650mm)	117-7046
c	start capacitor (80µF)	117U5373
e	run capacitor (10µF, 6.3mm)	117-7112

Model

Designation **SC18MLX.3** **220-240V/50Hz** Conf. 3 Sales code: **104L2146**

Optimization + standard conditions

R448A, 220V/50Hz, CSCR, fan 3m/s,

		Evaporating pressure (saturation temperature)				Condensing pressure (saturation temperature)						Power consumption			
		Return gas temp.				Liquid temp.						Current consumption			Ref. mass flow
		Cooling capacity				COP		EER		P1	I	m			
		pe	pc	RGT	Tliq	[W]	[Btu/h]	[kcal/h]	[W/W]	[Btu/Wh]	[kcal/Wh]	[W]	[A]	[kg/h]	
[°C]	-7	54	35	46	1537,7	5252	1323,4	1,68	5,73	1,44	916,1	4,44	33,59	ASHRAE MBP	
[°F]	20	130	95	115											
[°C]	-10	55	32	55	1182,0	4037	1017,2	1,37	4,69	1,18	861,1	4,28	28,95	cecomaf MBP	
[°F]	14	131	90	131											
[°C]	-10	45	20	45	1355,9	4631	1166,9	1,71	5,84	1,47	792,8	4,09	31,72	EN12900 MBP	
[°F]	14	113	68	113											
[°C]	-7	49	18	49	1451,6	4958	1249,3	1,67	5,69	1,43	871,0	4,31	36,10	ARI540 MBP	
[°F]	20	120	65	120											
[°C]	-10	45	32	45	1411,0	4819	1214,3	1,78	6,08	1,53	792,8	4,09	30,83	opt	
[°F]	14	113	90	113											
[°C]	-25	45	32	45	700,8	2393	603,1	1,23	4,19	1,06	571,1	3,47	15,07	opt	
[°F]	-13	113	90	113											

Performance tables

R448A, 220V/50Hz, CSCR, fan 3m/s,

	pe		Cooling capacity			COP	EER		P1	I	m
	[°C]	[°F]	[W]	[Btu/h]	[kcal/h]	[W/W]	[Btu/Wh]	[kcal/Wh]	[W]	[A]	[kg/h]
[°C / °F]	-20	-4	895,6	3059	770,8	1,39	4,75	1,20	644,3	3,68	19,34
cond. pressure	-15	5	1130,6	3861	973,0	1,57	5,38	1,35	718,3	3,88	24,55
pc= 45/113	-10	14	1411,0	4819	1214,3	1,78	6,08	1,53	792,8	4,09	30,83
return gas temp.	-7	20	1623,5	5545	1397,2	1,93	6,59	1,66	842,0	4,23	35,64
RGT= 32/90	-5	23	1742,2	5950	1499,3	2,01	6,86	1,73	867,3	4,30	38,35
liquid temp	0	32	2129,4	7272	1832,6	2,26	7,72	1,95	941,5	4,51	47,29
Tliq= 45/113	7,2	45	2796,1	9549	2406,4	2,67	9,12	2,30	1046,8	4,80	63,07
[°C / °F]	-20	-4	746,1	2548	642,1	1,09	3,71	0,94	686,5	3,80	18,04
cond. pressure	-15	5	943,3	3222	811,8	1,22	4,17	1,05	772,8	4,04	22,94
pc= 55/131	-10	14	1182,0	4037	1017,2	1,37	4,69	1,18	861,1	4,28	28,95
return gas temp	-7	20	1364,7	4661	1174,5	1,48	5,06	1,28	920,2	4,45	33,60
RGT= 32/90	-5	23	1467,3	5011	1262,8	1,54	5,27	1,33	950,9	4,54	36,24
liquid temp	0	32	1804,8	6164	1553,2	1,73	5,92	1,49	1041,9	4,79	45,01
Tliq= 55/131	7,2	45	2392,7	8172	2059,2	2,04	6,96	1,75	1174,1	5,16	60,73

Model

Designation	SC18MLX.3	220-240V/50Hz	Conf. 4	Sales code:	104L2146
-------------	------------------	----------------------	---------	-------------	-----------------

Configuration

Motorconfiguration	CSCR
Power supply (nominal)	220-240V/50Hz 1~
Refrigerant	R449A
Application	MBP
Voltage range	198-254V
Starting torque	HST
Approvals	

Electrical accessories / wiring diagram

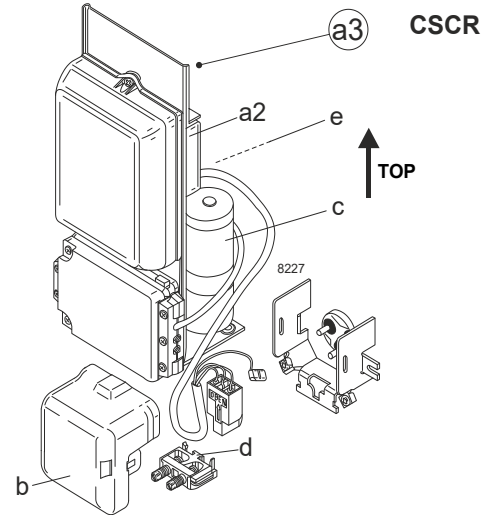

Ambient/ machine room temperatures minimum /maximum

Ambient temperature range: 10 - 38°C / 50 - 101°F

Machine room temperature range: 10 - 43°C / 50 - 110°F

Compressor cooling: fan 3m/s

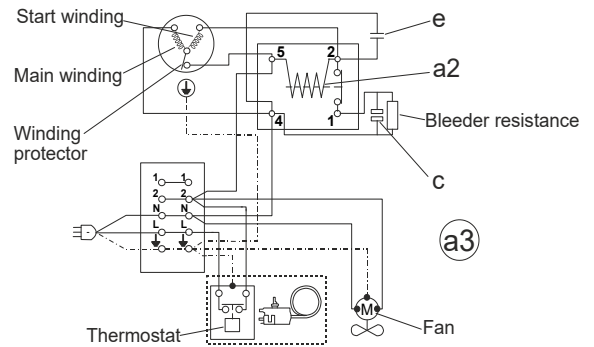

Operation Limits

Operation pressure range

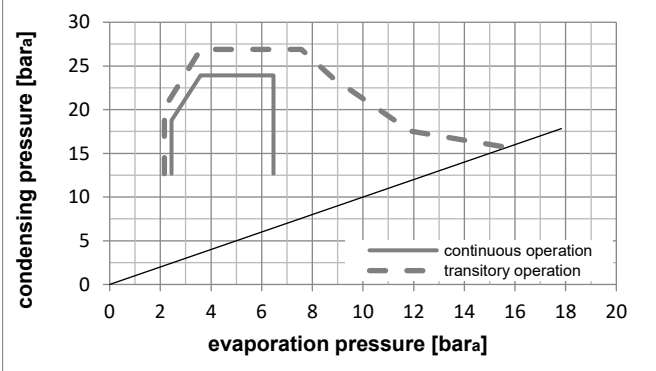
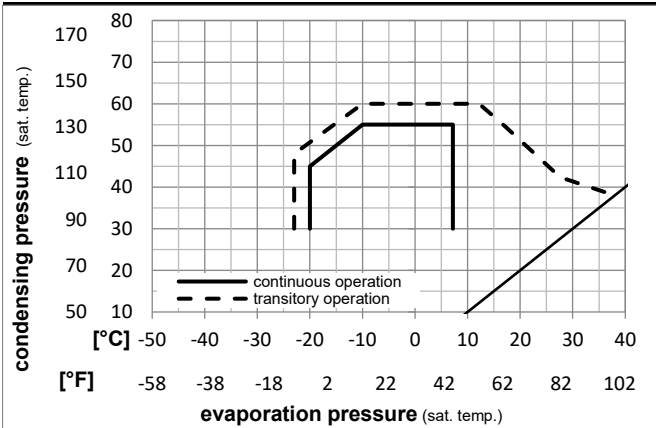

Components

a3	SC starter kit (550mm)	117-7027
b	plastic cover	103N2009
d	cord relief	103N1004

Alternative components

a3	SC starter kit (1000mm)	117-7040
a3	SC starter kit (650mm)	117-7046
c	start capacitor (80µF)	117U5373
e	run capacitor (10µF, 6.3mm)	117-7112

Model

Designation **SC18MLX.3** **220-240V/50Hz** Conf. 4 Sales code: **104L2146**

Optimization + standard conditions

R449A, 220V/50Hz, CSCR, fan 3m/s,

		Evaporating pressure (saturation temperature)				Cooling capacity			COP	EER	Power consumption				
		Condensing pressure (saturation temperature)				Return gas temp.					Current consumption				
		Liquid temp.				Cooling capacity					Ref. mass flow				
		pe	pc	RGT	Tliq	[W]	[Btu/h]	[kcal/h]	[W/W]	[Btu/Wh]	[kcal/Wh]	P1	I	m	
[°C]	[°F]	[°C]	[°F]	[°C]	[°C]							[W]	[A]	[kg/h]	
-7	20	54	130	35	46	1529,4	5223	1316,2	1,68	5,73	1,44	911,1	4,42	34,07	ASHRAE MBP
-10	14	55	131	32	55	1174,1	4010	1010,4	1,37	4,68	1,18	856,8	4,27	29,36	cecomaf MBP
-10	14	45	113	20	45	1347,0	4600	1159,2	1,71	5,83	1,47	789,4	4,08	32,17	EN12900 MBP
-7	20	49	120	18	49	1440,7	4920	1239,9	1,66	5,68	1,43	866,7	4,30	36,62	ARI540 MBP
-10	14	45	113	32	45	1403,1	4792	1207,6	1,78	6,07	1,53	789,4	4,08	31,27	opt
-25	-13	45	113	32	45	697,8	2383	600,6	1,23	4,18	1,05	569,5	3,47	15,30	opt

Performance tables

R449A, 220V/50Hz, CSCR, fan 3m/s,

	pe		Cooling capacity			COP	EER		P1	I	m
	[°C]	[°F]	[W]	[Btu/h]	[kcal/h]	[W/W]	[Btu/Wh]	[kcal/Wh]	[W]	[A]	[kg/h]
[°C / °F]	-20	-4	891,3	3044	767,1	1,39	4,74	1,19	642,1	3,67	19,63
cond. pressure	-15	5	1124,7	3841	967,9	1,57	5,37	1,35	715,6	3,88	24,90
pc= 45/113	-10	14	1403,1	4792	1207,6	1,78	6,07	1,53	789,4	4,08	31,27
return gas temp.	-7	20	1614,2	5513	1389,2	1,93	6,58	1,66	838,1	4,22	36,14
RGT= 32/90	-5	23	1731,9	5915	1490,5	2,01	6,85	1,73	863,2	4,29	38,89
liquid temp	0	32	2116,3	7228	1821,4	2,26	7,72	1,94	936,6	4,50	47,94
Tliq= 45/113	7,2	45	2778,2	9488	2391,0	2,67	9,12	2,30	1040,5	4,79	63,93
[°C / °F]	-20	-4	741,8	2533	638,4	1,08	3,70	0,93	684,0	3,79	18,31
cond. pressure	-15	5	937,4	3201	806,7	1,22	4,16	1,05	769,4	4,03	23,28
pc= 55/131	-10	14	1174,1	4010	1010,4	1,37	4,68	1,18	856,8	4,27	29,36
return gas temp	-7	20	1355,3	4629	1166,4	1,48	5,06	1,27	915,2	4,44	34,08
RGT= 32/90	-5	23	1457,1	4976	1254,0	1,54	5,26	1,33	945,5	4,52	36,75
liquid temp	0	32	1791,7	6119	1542,0	1,73	5,91	1,49	1035,2	4,77	45,65
Tliq= 55/131	7,2	45	2374,8	8110	2043,8	2,04	6,96	1,75	1165,4	5,14	61,58



SC Compressors





SC Compressors

Service/Repair – R290



8545



Secop accepts no responsibility for possible errors in catalogs, brochures, and other printed material. Secop reserves the right to alter its products without notice. This also applies to products already on order provided that such alterations can be made without subsequent changes being necessary to specifications already agreed. All trademarks in this material are the property of the respective companies. Secop and the Secop logotype are trademarks of Secop GmbH. All rights reserved. www.secop.com