

## Single Pack SC18G 208-230V 60Hz CSCR

Single pack code number: **195B4343**

Position	Title	Code	Amount
1	Compressor SC18G	104G8823	1
2	SC starting device (550mm)	117-7039	1
3	Cord relief	103N1004	1
4	Cover	103N2008	1
5	Bolt joint for one compressor   M6   ø16mm	118-1917	1

**Secop GmbH** • Lise-Meitner-Straße 29 • 24941 Flensburg, Germany • Tel: +49 461 4941 0 • [www.secop.com](http://www.secop.com)

Secop accepts no responsibility for possible errors in catalogs, brochures, and other printed material. Secop reserves the right to alter its products without notice. This also applies to products already on order provided that such alterations can be made without subsequent changes being necessary to specifications already agreed. All trademarks in this material are the property of the respective companies. Secop and the Secop logotype are trademarks of Secop GmbH. All rights reserved.

## SC18G Standard Compressor R134a 208-230V 60Hz

### General

Code number	104G8823
Approvals	UL984, KC
Compressors on pallet	80

### Application

Application	MBP			
	Hz	50	60	
Frequency	Hz	50	60	
Evaporating temperature	°C	-	-20 to 10	
Voltage range	V	-	187 - 254	
Max. condensing temperature continuous (short)	°C	-	60 (70)	
Max. winding temperature continuous (short)	°C	-	125 (135)	

### Cooling requirements

Frequency	Hz	50			60		
		LBP	MBP	HBP	LBP	MBP	HBP
32°C		-	-	-	-	F <sub>2</sub>	-
38°C		-	-	-	-	F <sub>2</sub>	-
43°C		-	-	-	-	F <sub>2</sub>	-
Remarks on application:							

### Motor

Motor type	CSR		
LRA (rated after 4 sec. UL984), HST   LST	A	21.8	-
Cut in Current, HST   LST	A	21.8	-
Resistance, main   start winding (25°C)	Ω	3.5	12.1

### Design

Displacement	cm <sup>3</sup>	17.69
Oil quantity (type)	cm <sup>3</sup>	550 (polyolester)
Maximum refrigerant charge	g	1300
Free gas volume in compressor	cm <sup>3</sup>	1460
Weight without electrical equipment	kg	13.7

### Dimensions

Height	mm	A			
		219			
Suction connector	location/I.D. mm   angle	C	10.2   37°		
		material   comment		Copper   Rubber plug	
		Process connector	location/I.D. mm   angle	D	6.5   37°
				material   comment	
Discharge connector	location/I.D. mm   angle	E	6.5   37°		
		material   comment		Copper   Rubber plug	
Oil cooler connector	location/I.D. mm   angle	F	-		
material   comment		-			
Connector tolerance	I.D. mm	±0.09			
Remarks:					

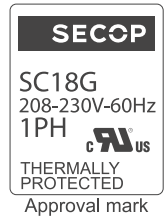
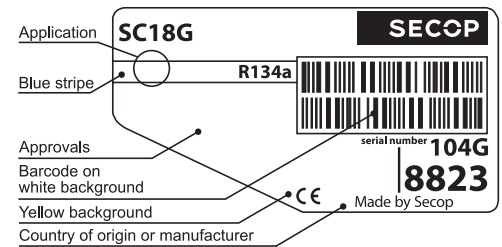

- S = Static cooling normally sufficient
- O = Oil cooling
- F<sub>1</sub> = Fan cooling 1.5 m/s (compressor compartment temperature equal to ambient temperature)
- F<sub>2</sub> = Fan cooling 3.0 m/s necessary
- SG = Suction gas cooling normally sufficient
- = not applicable in this area

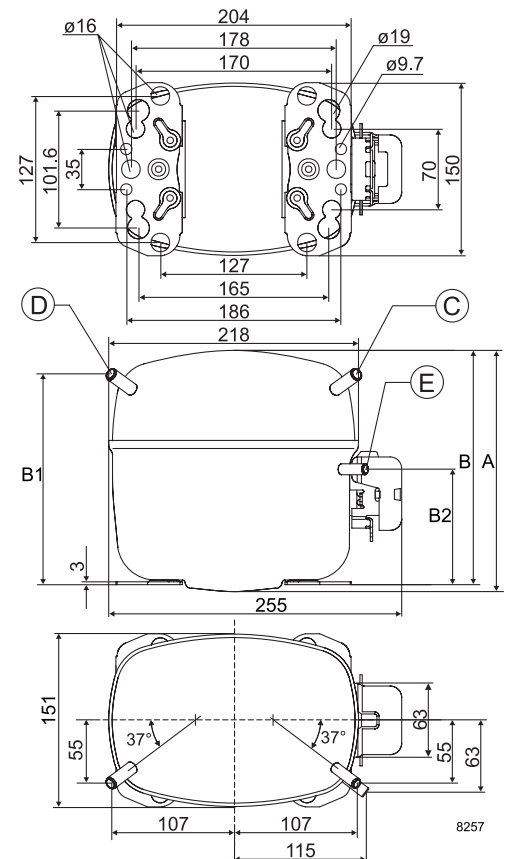

**EN 12900 Household (CECOMAF)**

230V, 60Hz, fan cooling F<sub>2</sub>

Evap. temp. in °C	-45	-40	-35	-30	-25	-23.3	-20	-15	-10	-6.7	-5	0	5	7.2	10	15	20
Capacity in W							432	573	745	879	955	1207	1506	1654	1858		
Power cons. in W							393	449	511	554	577	643	708	736	770		
Current cons. in A							1.83	2.14	2.45	2.65	2.75	3.05	3.35	3.48	3.65		
COP in W/W							1.10	1.27	1.46	1.59	1.66	1.88	2.13	2.25	2.41		

**ASHRAE MBP**

230V, 60Hz, fan cooling F<sub>2</sub>

Evap. temp. in °C	-45	-40	-35	-30	-25	-23.3	-20	-15	-10	-6.7	-5	0	5	7.2	10	15	20
Capacity in W							476	630	820	967	1050	1328	1657	1820	2045		
Power cons. in W							392	449	510	553	575	641	705	733	766		
Current cons. in A							1.84	2.15	2.45	2.65	2.75	3.05	3.34	3.47	3.63		
COP in W/W							1.21	1.40	1.61	1.75	1.83	2.07	2.35	2.48	2.67		

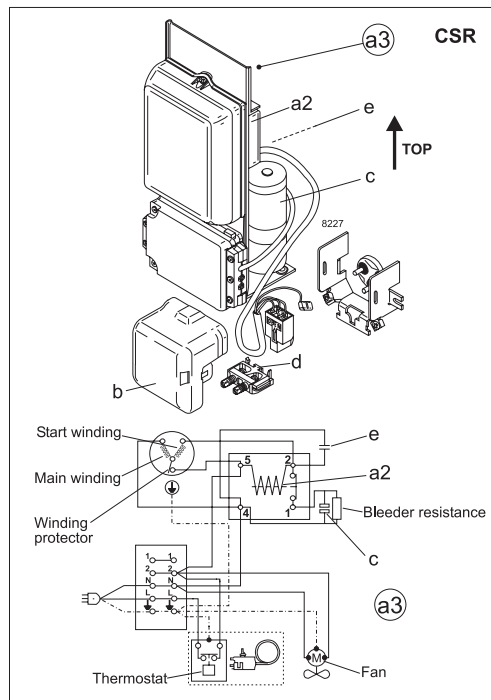

Accessories for	SC18G	Figure	Code number
Starting device	550 mm cable length	a3	117-7039
	1000 mm cable length		117-7043
Cover		b	103N2008
Starting relay		a2	Components of starting device
Starting capacitor		c	
Run capacitor		e	
Cord relief		d	103N1004

Test conditions	EN 12900/CECOMAF	ASHRAE MBP
Condensing temperature	55°C	54.4°C
Ambient temperature	32°C	35°C
Suction gas temperature	32°C	35°C
Liquid temperature	no subcooling	46.1°C

Mounting accessories		Code number
Bolt joint for one comp.	Ø: 16 mm	118-1917
Bolt joint in quantities	Ø: 16 mm	118-1918
Snap-on in quantities	Ø: 16 mm	118-1919

Secop accepts no responsibility for possible errors in catalogs, brochures, and other printed material. Secop reserves the right to alter its products without notice. This also applies to products already on order provided that such alterations can be made without subsequential changes being necessary to specifications already agreed. All trademarks in this material are the property of the respective companies. Secop and the Secop logotype are trademarks of Secop GmbH. All rights reserved. [www.secop.com](http://www.secop.com)



# SC Compressors





# SC Compressors

## Service/Repair – R290



8545



Secop accepts no responsibility for possible errors in catalogs, brochures, and other printed material. Secop reserves the right to alter its products without notice. This also applies to products already on order provided that such alterations can be made without subsequent changes being necessary to specifications already agreed. All trademarks in this material are the property of the respective companies. Secop and the Secop logotype are trademarks of Secop GmbH. All rights reserved. [www.secop.com](http://www.secop.com)