

Single Pack SLVE18CN 220-240V 50Hz / 208-230V 60Hz PM

Single pack code number: **195B4413**

Position	Title	Code	Amount
1	Compressor SLVE18CN	104H8841	1
2	Electronic unit	105N4731	1
3	Cover	103N2008	1
4	Bolt joint for one compressor M6 ø16mm	118-1917	1

Secop GmbH • Lise-Meitner-Straße 29 • 24941 Flensburg, Germany • Tel: +49 461 4941 0 • www.secop.com

Secop accepts no responsibility for possible errors in catalogs, brochures, and other printed material. Secop reserves the right to alter its products without notice. This also applies to products already on order provided that such alterations can be made without subsequent changes being necessary to specifications already agreed. All trademarks in this material are the property of the respective companies. Secop and the Secop logotype are trademarks of Secop GmbH. All rights reserved.

SLVE18CN Variable Speed Drive Compressor R290, 208-240V 50/60Hz - with 105N473x Series Controllers



General

Code number (without electronic unit)	104H8841
Electronic unit - Standard, 700±20 mm cable length	
Approvals: EN 60335-2-34 with Annex AA, CCC, UL 60335-2-34 with Annex AA	105N4730 (with PFC)
Compressors on pallet	80
Remarks: PFC = power factor correction according to EN 61000-3-2:2014	

Application

Application	Hz	LBP/MBP	
		50	60
Frequency	Hz	50	60
Evaporating temperature	°C	-45 to 10	-45 to 10
Voltage range / frequency	V/Hz	180 - 270	180 - 270
Max. condensing temperature continuous (short)	°C	60 (65)	60 (65)
Max. winding temperature continuous (short)	°C	125 (135)	125 (135)

Cooling requirements

Frequency	Hz	Cooling requirements					
		50			60		
Application		LBP	MBP	HBP	LBP	MBP	HBP
32°C		F ₂	F ₂	-	F ₂	F ₂	-
38°C		F ₂	F ₂	-	F ₂	F ₂	-
43°C		F ₂	F ₂	-	F ₂	F ₂	-

Features

Speed range	rpm	2200 - 4500
Speed control		AEO, frequency, serial com.
Protections		current, speed, temperature
Protection class (electronic unit)		IP54

Motor

Motor type		permanent magnet
LRA (rated after 4 sec. UL984)	A	electronic cut off
Maximum current	A	7.0
Resistance, all 3 windings (25°C)	Ω	3.9

Design

Displacement	cm ³	17.70
Oil quantity (type)	cm ³	550 (polyolester)
Maximum refrigerant charge (tech. limit)	g	550
Free gas volume in compressor	cm ³	1460
Weight - Compressor/Electronic unit	kg	14.2 / 1.2

Dimensions

Height	mm	A	219
		B	213
		B1	193
		B2	110
Suction connector	location/I.D. mm angle	C	10.2 37°
	material comment		Copper Rubber plug
Process connector	location/I.D. mm angle	D	6.2 37°
	material comment		Copper Rubber plug
Discharge connector	location/I.D. mm angle	E	6.2 37°
	material comment		Copper Rubber plug
Connector tolerance	I.D. mm		±0.09

Accessories

Cover	Code number	103N2008
-------	-------------	----------

Mounting accessories

Bolt joint for one compressor	Ø: 16 mm	118-1958
Bolt joint in quantities	Ø: 16 mm	118-1961
Snap-on in quantities	Ø: 16 mm	118-1962

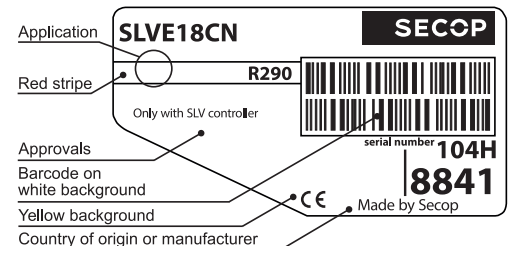

- S = Static cooling normally sufficient
- O = Oil cooling
- F₁ = Fan cooling 1.5 m/s (compressor compartment temp. equal to ambient temperature)
- F₂ = Fan cooling 3.0 m/s necessary
- SG = Suction gas cooling normally sufficient
- = not applicable in this area



Yellow warning label

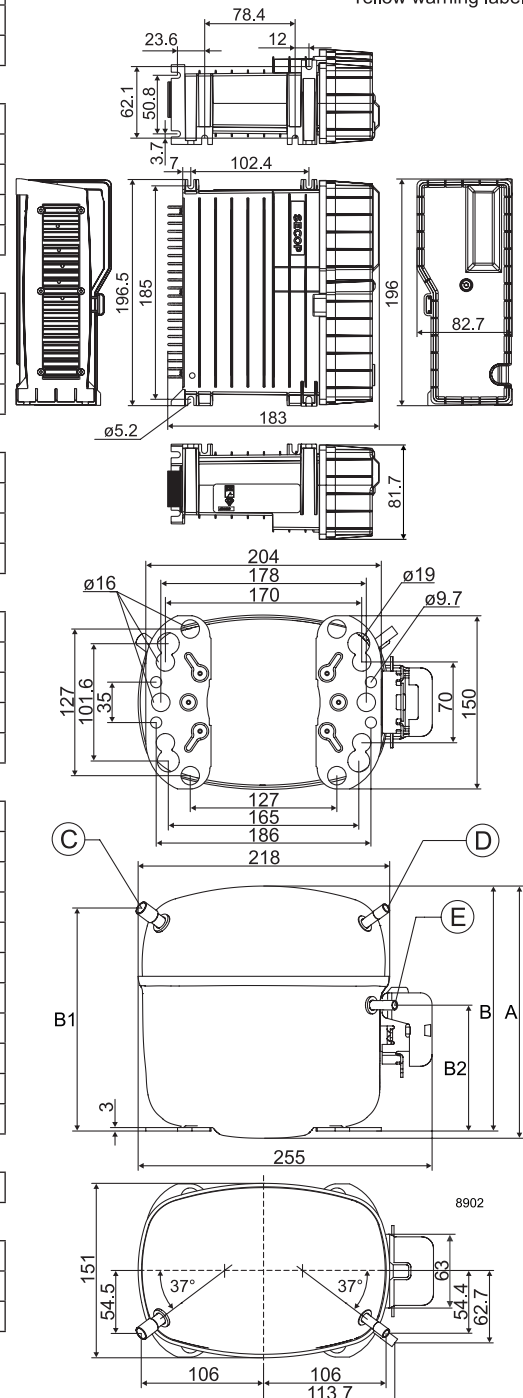

LBP: ASHRAE 230V, 50/60Hz, fan cooling F₂

Speed (rpm)	2200	2400	2600	2800	3000	3500	4000	4500
Capacity [W]	666	721	776	832	887	989	1091	1192
Capacity [BTU/h]	2275	2462	2650	2840	3029	3377	3725	4072
Power cons. [W]	386	416	446	476	505	575	645	714
Current cons. [A]	1.79	1.98	2.13	2.26	2.38	2.67	2.95	3.23
COP [W/W]	1.73	1.73	1.74	1.75	1.76	1.72	1.69	1.67
EER [BTU/Wh]	5.90	5.92	5.94	5.97	6.00	5.87	5.78	5.70

Test conditions

Evaporation pressure	-23.3°C	-10°F
Condensing pressure	54.4°C	130°F
Liquid temperature	32.2°C	90°F
Return gas temperature	32.2°C	90°F

LBP: CECOMAF 230V, 50/60Hz, fan cooling F₂

Speed (rpm)	2200	2400	2600	2800	3000	3500	4000	4500
Capacity [W]	497	537	578	620	661	737	813	889
Capacity [BTU/h]	1696	1835	1975	2117	2258	2517	2776	3035
Power cons. [W]	371	400	429	458	486	553	620	688
Current cons. [A]	1.73	1.91	2.06	2.18	2.31	2.58	2.84	3.11
COP [W/W]	1.34	1.34	1.35	1.36	1.36	1.33	1.31	1.29
EER [BTU/Wh]	4.57	4.59	4.6	4.63	4.64	4.55	4.48	4.42

Test conditions

Evaporation pressure	-25°C	-13°F
Condensing pressure	55°C	131°F
Liquid temperature	55°C	131°F
Return gas temperature	32°C	90°F

LBP: EN12900

Speed (rpm)	2200	2400	2600	2800	3000	3500	4000	4500
Capacity [W]	361	391	421	451	481	536	592	
Capacity [BTU/h]	1234	1336	1438	1541	1643	1832	2021	
Power cons. [W]	262	283	303	323	343	391	438	
Current cons. [A]	1.24	1.39	1.52	1.63	1.74	1.90	2.06	
COP [W/W]	1.38	1.38	1.39	1.40	1.40	1.37	1.35	
EER [BTU/Wh]	4.71	4.73	4.75	4.77	4.79	4.69	4.61	

Test conditions

Evaporation pressure	-35°C	-31°F
Condensing pressure	40°C	104°F
Liquid temperature	40°C	104°F
Return gas temperature	20°C	68°F

MBP: ASHRAE 230V, 50/60Hz, fan cooling F₂

Speed (rpm)	2200	2400	2600	2800	3000	3500	4000	4500
Capacity [W]	1199	1298	1397	1497	1597	1780	1963	2146
Capacity [BTU/h]	4095	4431	4770	5111	5452	6078	6704	7330
Power cons. [W]	542	584	626	668	710	808	906	1004
Current cons. [A]	2.49	2.72	2.91	3.06	3.20	3.64	4.07	4.50
COP [W/W]	2.21	2.22	2.23	2.24	2.25	2.20	2.17	2.14
EER [BTU/Wh]	7.56	7.59	7.62	7.65	7.68	7.53	7.40	7.30

Test conditions

Evaporation pressure	-6.7°C	20°F
Condensing pressure	54.4°C	130°F
Liquid temperature	46.1°C	115°F
Return gas temperature	35°C	95°F

MBP: CECOMAF 230V, 50/60Hz, fan cooling F₂

Speed (rpm)	2200	2400	2600	2800	3000	3500	4000	4500
Capacity [W]	954	1032	1111	1191	1270	1416	1562	1708
Capacity [BTU/h]	3258	3526	3795	4067	4338	4836	5334	5832
Power cons. [W]	516	557	597	637	676	770	863	956
Current cons. [A]	2.38	2.60	2.78	2.93	3.07	3.48	3.89	4.30
COP [W/W]	1.85	1.86	1.86	1.87	1.88	1.84	1.81	1.79
EER [BTU/Wh]	6.31	6.33	6.36	6.39	6.41	6.28	6.18	6.10

Test conditions

Evaporation pressure	-10°C	14°F
Condensing pressure	55°C	131°F
Liquid temperature	55°C	131°F
Return gas temperature	32°C	90°F

MBP: EN12900 230V, 50/60Hz, fan cooling F₂

Speed (rpm)	2200	2400	2600	2800	3000	3500	4000	4500
Capacity [W]	1044	1130	1216	1303	1390	1549	1709	1868
Capacity [BTU/h]	3564	3857	4152	4449	4746	5291	5836	6381
Power cons. [W]	463	500	536	572	607	692	775	859
Current cons. [A]	2.14	2.35	2.52	2.66	2.79	3.15	3.51	3.87
COP [W/W]	2.25	2.26	2.27	2.28	2.29	2.24	2.21	2.18
EER [BTU/Wh]	7.69	7.72	7.75	7.78	7.82	7.66	7.53	7.43

Test conditions

Evaporation pressure	-10°C	14°F
Condensing pressure	45°C	113°F
Liquid temperature	45°C	113°F
Return gas temperature	20°C	68°F

Optimization Point 230V, 50/60Hz, fan cooling F₂

Speed (rpm)	2200	2400	2600	2800	3000	3500	4000	4500
Capacity [W]	651	705	759	813	867	967	1066	1166
Capacity [BTU/h]	2224	2407	2591	2777	2962	3302	3642	3982
Power cons. [W]	320	345	370	395	419	477	535	593
Current cons. [A]	1.50	1.66	1.81	1.92	2.04	2.26	2.48	2.70
COP [W/W]	2.04	2.04	2.05	2.06	2.07	2.03	1.99	1.97
EER [BTU/Wh]	6.95	6.97	7.00	7.03	7.06	6.92	6.80	6.71

Test conditions

Evaporation pressure	-25°C	-13°F
Condensing pressure	35°C	95°F
Liquid temperature	35°C	95°F
Return gas temperature	32°C	90°F

Optimization Point 230V, 50/60Hz, fan cooling F₂

Speed (rpm)	2200	2400	2600	2800	3000	3500	4000	4500
Capacity [W]	1087	1176	1266	1356	1447	1613	1779	1945
Capacity [BTU/h]	3711	4016	4323	4632	4941	5508	6075	6643
Power cons. [W]	463	500	536	572	607	691	775	859
Current cons. [A]	2.14	2.35	2.52	2.66	2.79	3.15	3.51	3.87
COP [W/W]	2.35	2.35	2.36	2.37	2.38	2.33	2.30	2.27
EER [BTU/Wh]	8.01	8.03	8.07	8.10	8.14	7.97	7.84	7.73

Test conditions

Evaporation pressure	-10°C	14°F
Condensing pressure	45°C	113°F
Liquid temperature	45°C	113°F
Return gas temperature	32°C	90°F

Optimization Point 230V, 50/60Hz, fan cooling F₂

Speed (rpm)	2200	2400	2600	2800	3000	3500	4000	4500
Capacity [W]		1992	2144	2297	2451	2732	3013	3295
Capacity [BTU/h]		6802	7322	7846	8370	9330	10291	11252
Power cons. [W]		570	611	651	692	787	883	979
Current cons. [A]		2.66	2.84	2.99	3.13	3.55	3.97	4.39
COP [W/W]		3.50	3.51	3.53	3.54	3.47	3.41	3.37
EER [BTU/Wh]		11.94	11.99	12.05	12.10	11.85	11.65	11.50

Test conditions

Evaporation pressure	5°C	41°F
Condensing pressure	45°C	113°F
Liquid temperature	45°C	113°F
Return gas temperature	32°C	90°F

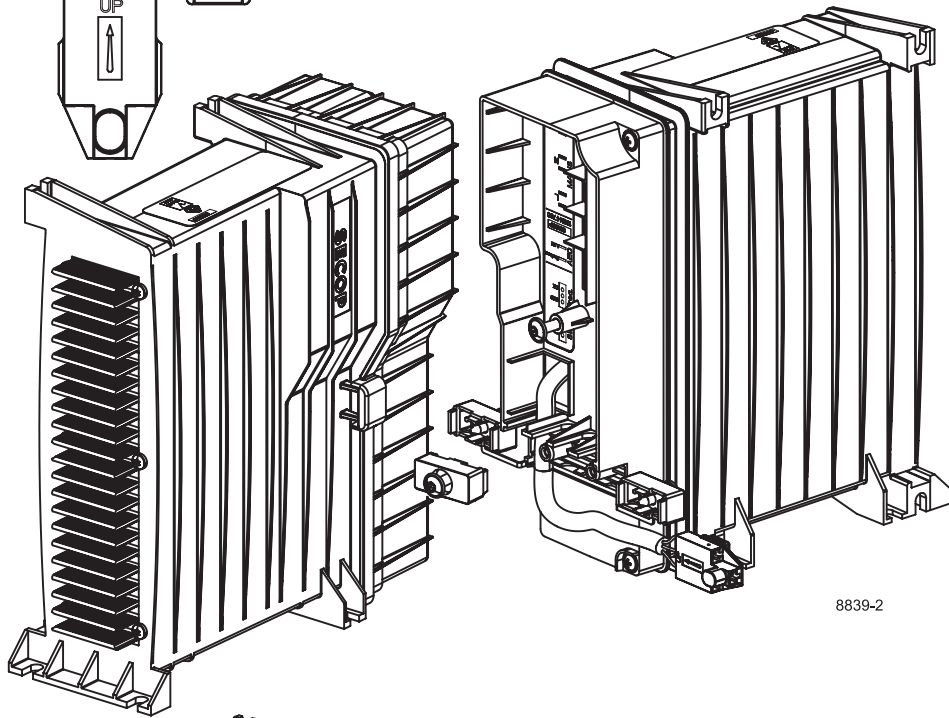
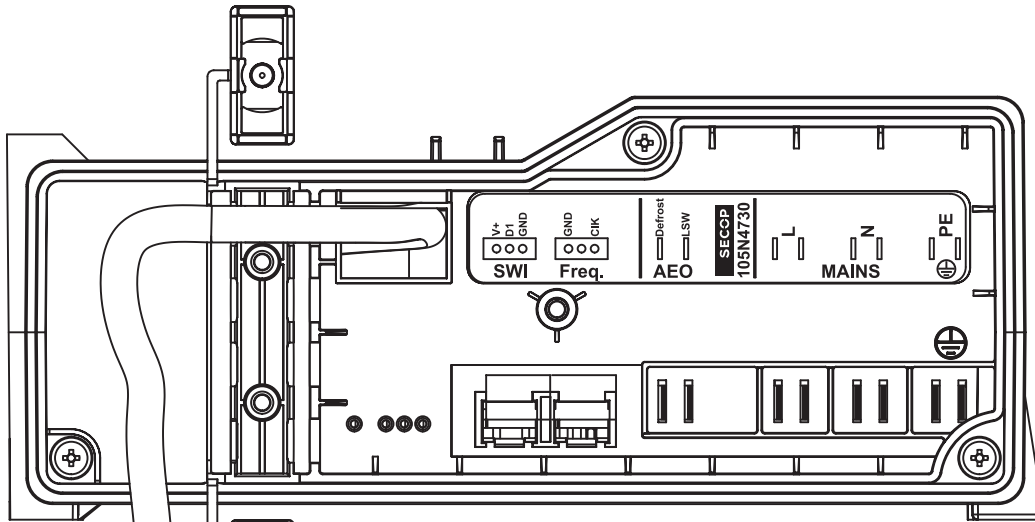

8839-2



RAST 2.5

Spade connectors 6.3 x 0.8

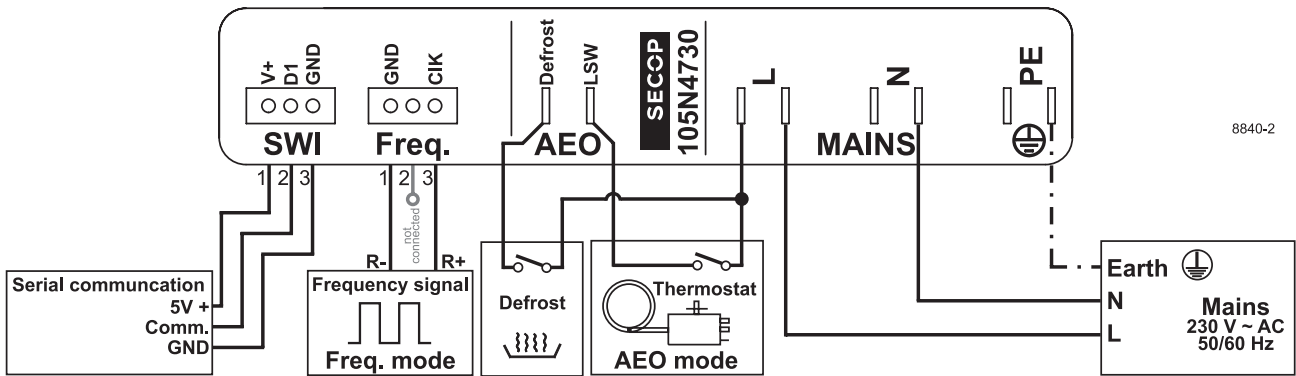

8840-2

Secop accepts no responsibility for possible errors in catalogs, brochures, and other printed material. Secop reserves the right to alter its products without notice. This also applies to products already on order provided that such alterations can be made without subsequential changes being necessary to specifications already agreed. All trademarks in this material are the property of the respective companies. Secop and the Secop logotype are trademarks of Secop GmbH. All rights reserved. www.secop.com

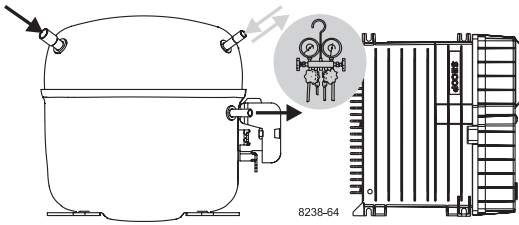

Instructions

SLVE Compressors
208-240V 50/60Hz
105N473x
Series Controllers

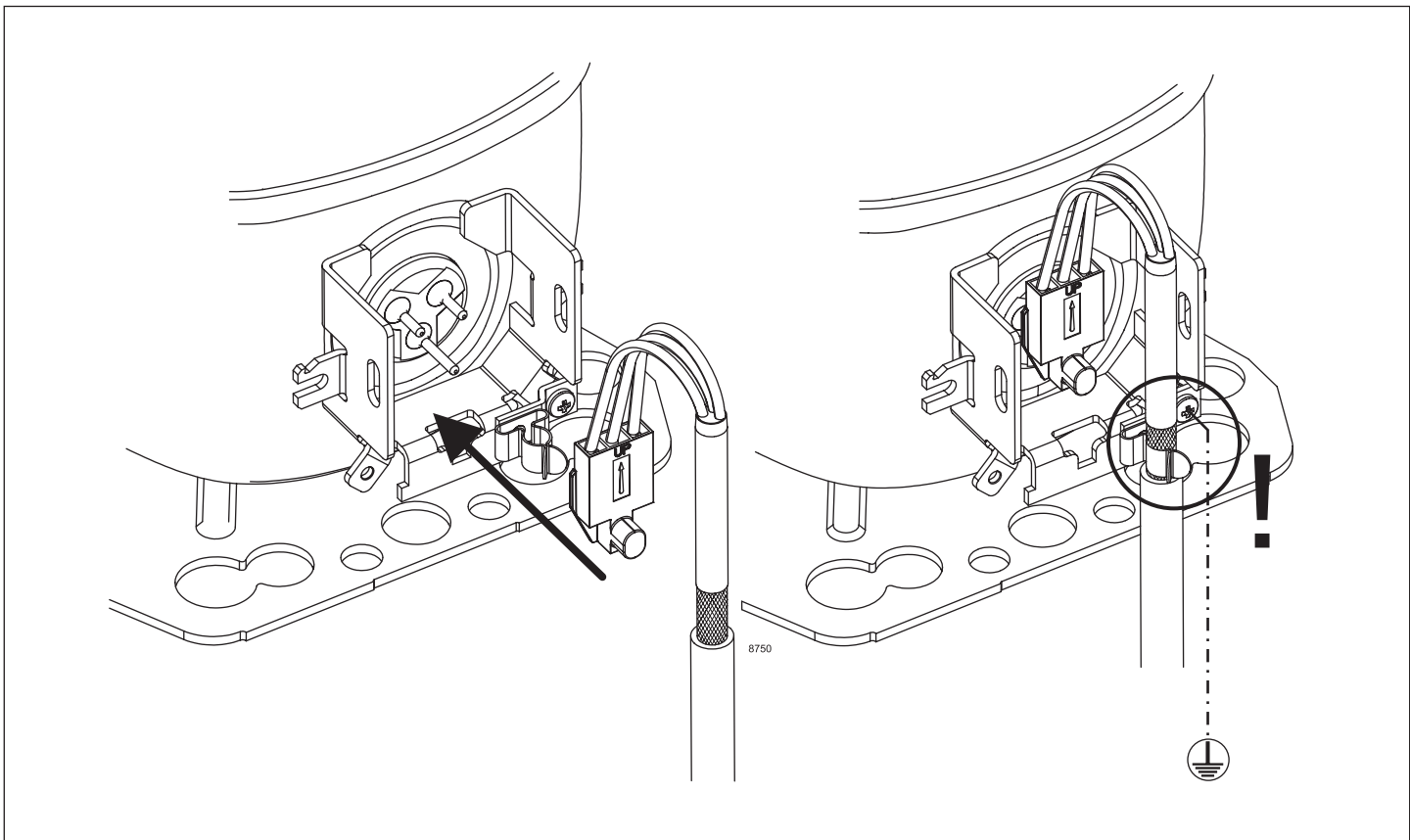
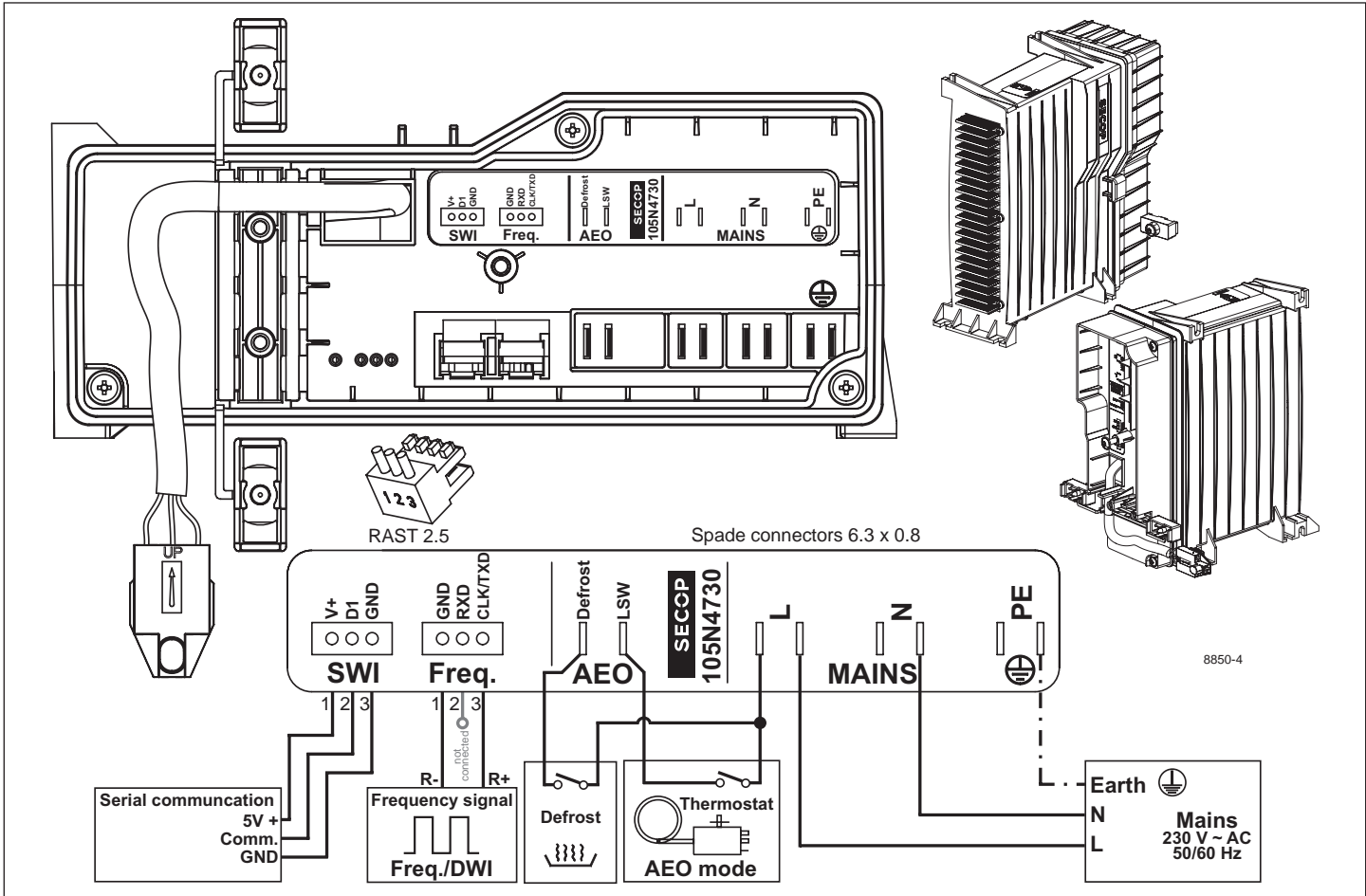
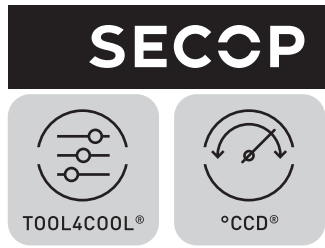

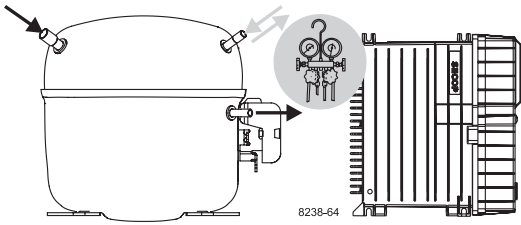

Instructions

SLVE Compressors
208-240V 50/60Hz
105N473x
Series Controllers

SECCP



Service/Repair R290

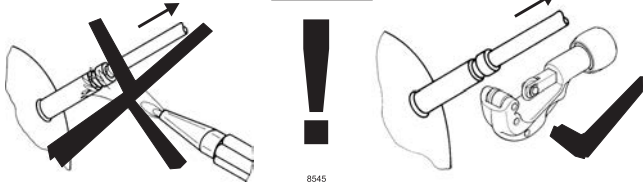

Brazing on Suction Connectors (Direct Intake)

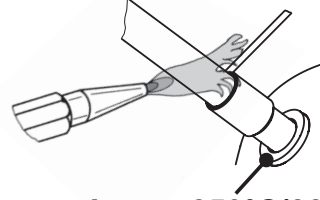

! max. 350°C/662°F !
at socket

brazing solder: phosphor (LP7) or silver

Refer to Product Bulletin: **Brazing on Suction Connectors**
(Compressors with Direct Suction Intake)

min. 3 m/s !

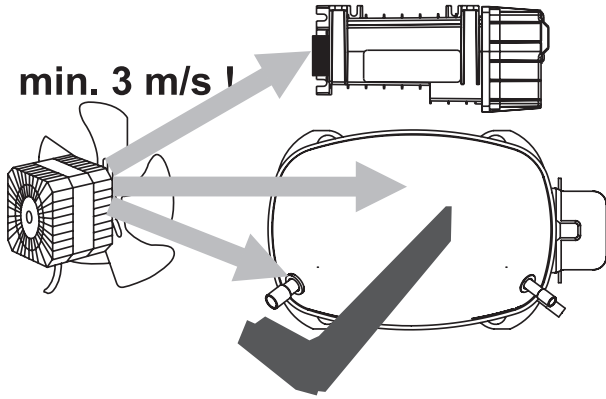

min. 3 m/s !

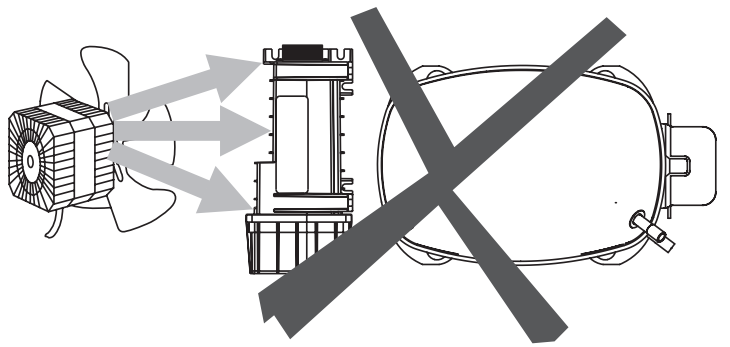
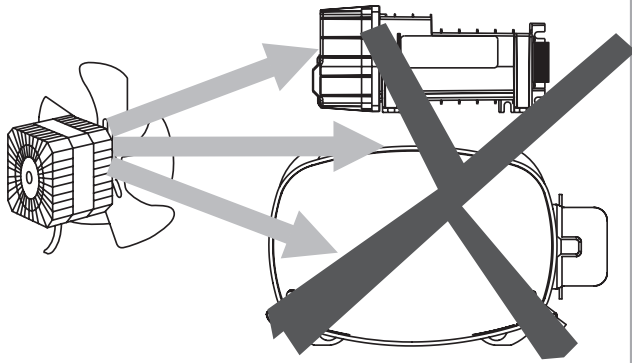
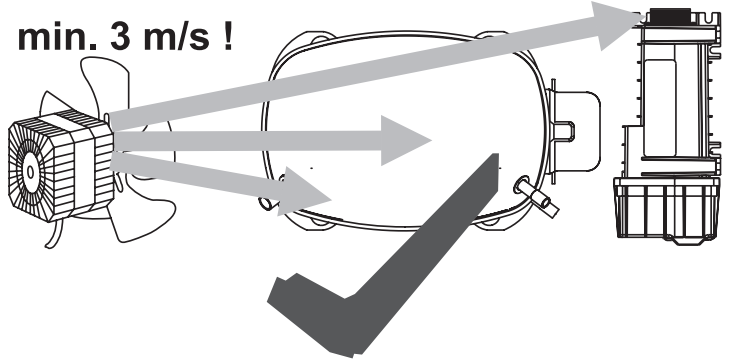

8903

Airflow	3 m/s
Operating conditions	+ 5 °C to 43 °C - humidity < 90 % rH non condensing
Storage conditions	-25 °C to 70 °C - humidity < 90 % rH non condensing
Supply voltage	208-240 V (±10%)
Frequency	50/60 Hz
Input power rating	1400 W at 230 V (+15 % / - 20 %)