

Single Pack SC15G 220-240V 50Hz / 208-230V 60Hz CSIR

Single pack code number: **195B4420**

Position	Title	Code	Amount
1	Compressor SC15G	104G8520	1
2	Starting relay	117U7005	1
3	Starting capacitor (80 μ F 220V, 6.3mm)	117U5017	1
4	Cord relief	103N1004	1
5	Cover	103N2009	1
6	Bolt joint for one compressor M6 \varnothing 16mm	118-1917	1

Secop GmbH • Lise-Meitner-Straße 29 • 24941 Flensburg, Germany • Tel: +49 461 4941 0 • www.secop.com

Secop accepts no responsibility for possible errors in catalogs, brochures, and other printed material. Secop reserves the right to alter its products without notice. This also applies to products already on order provided that such alterations can be made without subsequent changes being necessary to specifications already agreed. All trademarks in this material are the property of the respective companies. Secop and the Secop logotype are trademarks of Secop GmbH. All rights reserved.

Model

Designation	SC15G	220-240V/50Hz 1~ 208-230V/60Hz 1~	Sales code:	104G8520
-------------	--------------	-----------------------------------	-------------	-----------------

Compressor design

Oil type	Polyolester	Refrigerant(s)	R134a, R513A
Oil viscosity	22cST	Displacement	15,28cm ³ / 0,93cu.in
Oil quantity	507cm ³ / 17,1fl.oz	Compressors on pallet	80
Refr. charge - tech. limit	1300g / 45,9oz		
Free gas volume comp.	1410cm ³ / 47,7fl.oz		
Weight	13,2kg / 29,1lbs		
Motor protection	1# internal		
Winding resistance main	5,13Ω (at 25°C)		
Winding resistance aux	13,51Ω (at 25°C)		
Max. winding temp.	125°C / 257°F		
Max. discharge temp.	130°C / 266°F		



General - Configurations with SC15G

	Conf. 1	Conf. 2	Conf. 3	Conf. 4
Motorconfiguration	CSIR	CSIR	CSIR	CSIR
Power supply (nominal)	220-240V/50Hz	208-230V/60Hz	220-240V/50Hz	208-230V/60Hz
Number of phases	1	1	1	1
Voltage range	187-254V	198-254V	187-254V	198-254V
Approvals	VDE, CCC, EAC, KC	VDE, CCC, EAC, KC	VDE, CCC, UL	VDE, CCC, UL
Starting torque	HST	HST	HST	HST
Note	- / -			

Applications with SC15G

	Conf. 1	Conf. 2	Conf. 3	Conf. 4
Refrigerant	R134a	R134a	R513A	R513A
Application	LBP+MBP+HBP	LBP	LBP+MBP+HBP	LBP
System cooling	fan 3m/s	fan 3m/s	fan 3m/s	fan 3m/s
Hot gas defrost	OK	OK	OK	OK
Long interval pull down	OK	OK	OK	OK

Electrical data - Configurations with SC15G

	Conf. 1	Conf. 2	Conf. 3	Conf. 4
Starting device type	relay	relay	relay	relay
Run capacitor	- / -	- / -	- / -	- / -
Start capacitor	80μF	80μF	80μF	80μF
LRA (locked rotor amps / 4s)	16,2A	15,6A	16,2A	15,6A
RLA (rated load amps / 1s)	3,1A	2,8A	3,1A	2,8A
Cut in current	16,2A	15,6A	16,2A	15,6A

Model

Designation

SC15G

220-240V/50Hz 1~ 208-230V/60Hz 1~

Sales code:

104G8520

Compressor dimensions

Housing	A Height	209mm / 8,23in
	B Height	203mm / 7,99in
	C Length shell	218mm / 8,58in
	D Length w. cover	255mm / 10,04in
	E Width	151mm / 5,94in

Connectors	Suction X	Discharge Y	Process Z
Diameter [mm]	øi 10,11-10,29	øi 6,11-6,29	øi 6,11-6,29
(i:inside, o:outside) [in]	øi 0,4-0,41	øi 0,24-0,25	øi 0,24-0,25
Material	copper	copper	copper
Horizontal angle ±2°	37°	37°	143°
Vertical angle ±2°	30°	0°	150°
Position l/h/w [mm]	107/183/55	115/100/63	-107/183/55
[in]	4,2/7,2/2,2	4,5/3,9/2,5	-4,2/7,2/2,2
Straight tube l. [mm]	12	12	12
[in]	0,5	0,5	0,5



Compressor fixation



Bolt joint



Snap-on



Mounting accessories

Mounting accessories	one comp.	multi pack
Bolt joint M6 ø16mm	118-1917	118-1918
Bolt joint ø1/4" ø16mm	118-1946	
Bolt joint ø1/4" ø19mm	118-1949	
Snap-on ø7,3 ø16mm	118-1947	118-1919

Application notes

Operation possible until tilted up to 3 degrees

Provision for PE Grounding is located at the PE Stamp on the compressor

Model

Designation	SC15G	220-240V/50Hz	Conf. 1	Sales code:	104G8520
-------------	--------------	----------------------	----------------	-------------	-----------------

Configuration

Motorconfiguration	CSIR
Power supply (nominal)	220-240V/50Hz 1~
Refrigerant	R134a
Application	LBP+MBP+HBP
Voltage range	187-254V
Starting torque	HST
Approvals	VDE CCC EAC KC

Electrical accessories / wiring diagram

CSIR

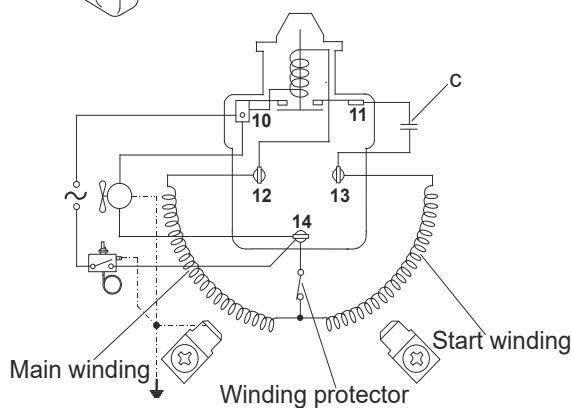
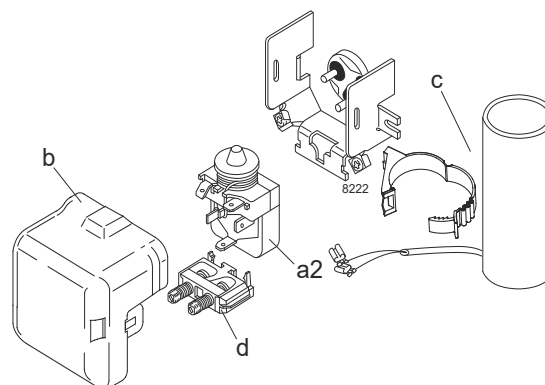

Ambient/ machine room temperatures minimum /maximum

Ambient temperature range: 10 - 43°C / 50 - 110°F

Machine room temperature range: 10 - 48°C / 50 - 119°F

Compressor cooling: fan 3m/s

Operation Limits

Operation pressure range

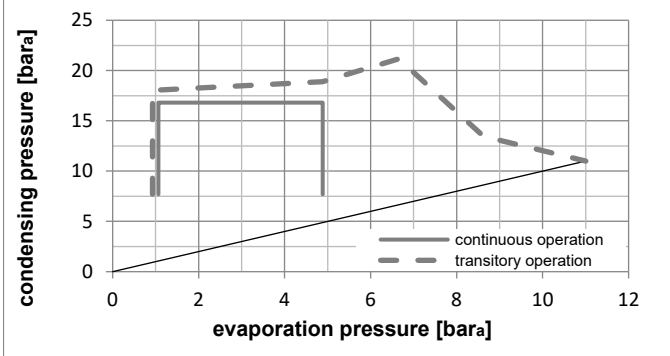
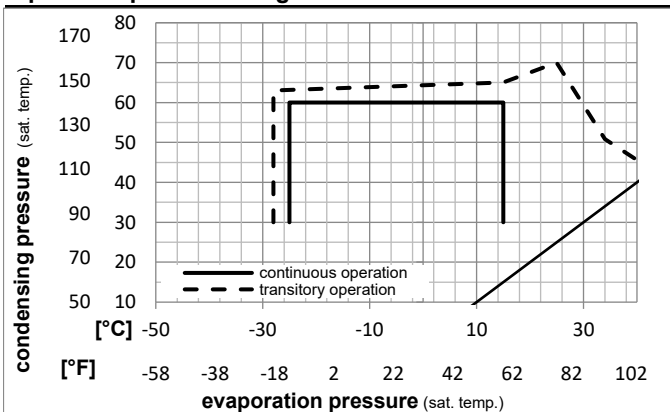

Components

a2	relay	117U6005
c	start capacitor (80μF)	117U5017
d	cord relief	103N1004
b	plastic cover	103N2009

Model

Designation	SC15G	220-240V/50Hz	Conf. 1	Sales code:	104G8520
-------------	--------------	----------------------	----------------	-------------	-----------------

Optimization + standard conditions

R134a, 220V/50Hz, CSIR, fan 3m/s, VDE, CCC, EAC, KC

	Evaporating pressure (saturation temperature)				Condensing pressure (saturation temperature)			Return gas temp.	Liquid temp.	Cooling capacity	COP	EER	Power consumption			ASHRAE LBP
	pe	pc	RGT	Tliq	[W]	[Btu/h]	[kcal/h]						P1	I	Ref. mass flow	
[°C]																
[°F]																
	-23	54	32	32	303,8	1037	261,4	1,10	3,76	0,95	275,6	2,27	5,90	ASHRAE LBP		
	-10	130	90	90												
	-25	55	32	55	214,0	731	184,2	0,83	2,83	0,71	257,9	2,21	5,12	cecomaf LBP		
	-13	131	90	131												
	-35	40	20	40	141,4	483	121,7	0,76	2,61	0,66	185,0	1,95	3,10	EN12900 LBP		
	-31	104	68	104												
	-7	54	35	46	742,4	2535	638,9	1,57	5,35	1,35	474,1	2,91	16,20	ASHRAE MBP		
	20	130	95	115												
	-10	55	32	55	566,0	1933	487,1	1,30	4,43	1,12	436,2	2,78	13,69	cecomaf MBP		
	14	131	90	131												
	-10	45	20	45	644,4	2201	554,6	1,58	5,41	1,36	407,1	2,66	15,08	EN12900 MBP		
	14	113	68	113												

Performance tables

R134a, 220V/50Hz, CSIR, fan 3m/s, VDE, CCC, EAC, KC

	pe		Cooling capacity			COP	EER	P1	I	m	
	[°C]	[°F]	[W]	[Btu/h]	[kcal/h]	[W/W]	[Btu/Wh]	[kcal/Wh]	[W]	[A]	[kg/h]
[°C / °F]	-25	-13	271,8	928	233,9	1,08	3,70	0,93	250,9	2,19	5,89
cond. pressure	-20	-4	380,2	1299	327,2	1,27	4,34	1,09	299,3	2,34	8,26
pc= 45/113	-10	14	668,5	2283	575,3	1,64	5,61	1,41	407,1	2,66	14,63
return gas temp.	-5	23	850,8	2906	732,2	1,84	6,30	1,59	461,2	2,83	18,71
RGT= 32/90	0	32	1060,1	3620	912,3	2,07	7,07	1,78	511,9	3,01	23,44
liquid temp	5	41	1297,5	4431	1116,7	2,33	7,96	2,01	556,4	3,19	28,89
Tliq= 45/113	15	59	1861,9	6359	1602,4	3,02	10,32	2,60	616,3	3,59	42,17
[°C / °F]	-25	-13	214,0	731	184,2	0,83	2,83	0,71	257,9	2,21	5,12
cond. pressure	-20	-4	311,8	1065	268,4	0,99	3,38	0,85	314,8	2,40	7,48
pc= 55/131	-10	14	566,0	1933	487,1	1,30	4,43	1,12	436,2	2,78	13,69
return gas temp	-5	23	724,9	2476	623,8	1,46	5,00	1,26	495,4	2,99	17,62
RGT= 32/90	0	32	906,4	3096	780,1	1,65	5,63	1,42	550,0	3,20	22,17
liquid temp	5	41	1111,9	3797	956,9	1,86	6,36	1,60	597,2	3,42	27,40
Tliq= 55/131	15	59	1599,5	5463	1376,6	2,43	8,29	2,09	659,0	3,88	40,18

Model

Designation	SC15G	208-230V/60Hz	Conf. 2	Sales code:	104G8520
-------------	--------------	----------------------	----------------	-------------	-----------------

Configuration

Motorconfiguration	CSIR
Power supply (nominal)	208-230V/60Hz 1~
Refrigerant	R134a
Application	LBP
Voltage range	198-254V
Starting torque	HST
Approvals	VDE CCC EAC KC

Electrical accessories / wiring diagram

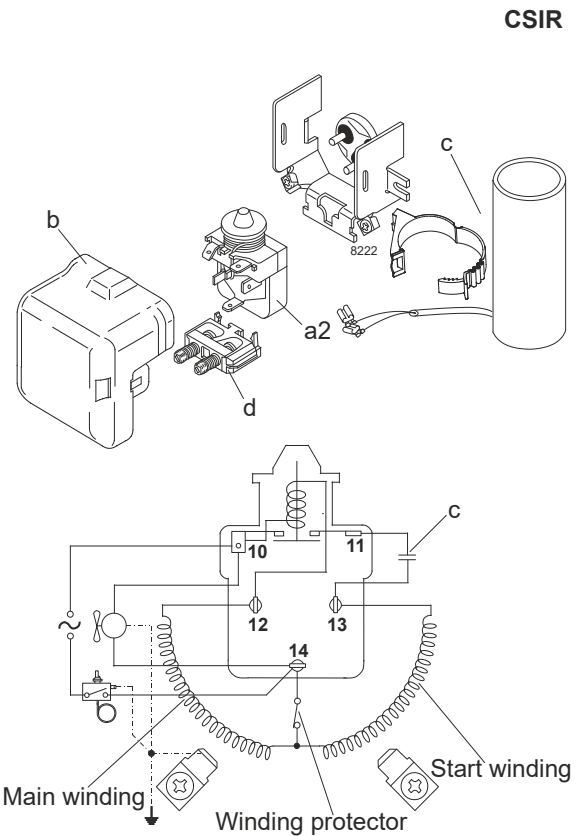

Ambient/ machine room temperatures minimum /maximum

Ambient temperature range:	10 - 43°C / 50 - 110°F
Machine room temperature range:	10 - 48°C / 50 - 119°F
Compressor cooling:	fan 3m/s

Operation Limits

Operation pressure range

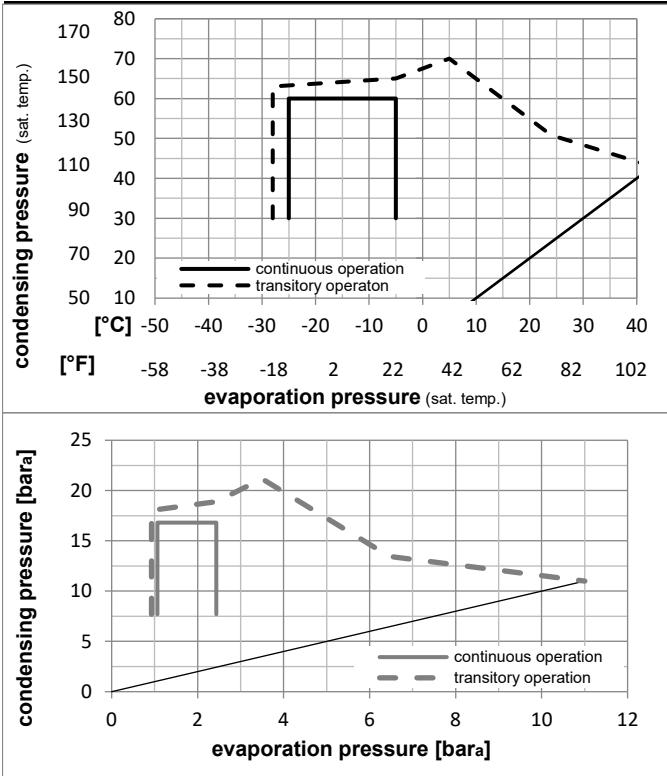

Components

a2	relay	117U6005
c	start capacitor (80μF)	117U5017
d	cord relief	103N1004
b	plastic cover	103N2009

Model

Designation **SC15G** **208-230V/60Hz** Conf. 2 Sales code: **104G8520**

Optimization + standard conditions

R134a, 230V/60Hz, CSIR, fan 3m/s, VDE, CCC, EAC, KC

		Evaporating pressure (saturation temperature)				Condensing pressure (saturation temperature)						Power consumption			
		Return gas temp.		Liquid temp.		Cooling capacity			COP	EER		Current consumption		Ref. mass flow	
		pe	pc	RGT	Tliq	[W]	[Btu/h]	[kcal/h]	[W/W]	[Btu/Wh]	[kcal/Wh]	P1	I	m	
[°C]	[°F]	[°C]	[°F]	[°C]	[°F]							[W]	[A]	[kg/h]	
[°C]	-23	54	32	32	370,0	1264	318,4	1,07	3,64	0,92	347,0	2,03	7,18	ASHRAE LBP	
[°F]	-10	130	90	90											
[°C]	-25	55	32	55	262,0	895	225,5	0,79	2,71	0,68	330,2	1,99	6,27	cecomaf LBP	
[°F]	-13	131	90	131											
[°C]	-35	40	20	40	167,8	573	144,4	0,94	3,22	0,81	177,9	1,56	3,68	EN12900 LBP	
[°F]	-31	104	68	104											
[°C]	-7	54	35	46	884,5	3021	761,2	1,64	5,59	1,41	540,7	2,73	19,30	ASHRAE MBP	
[°F]	20	130	95	115											
[°C]	-10	55	32	55	677,1	2312	582,7	1,34	4,57	1,15	505,6	2,59	16,37	cecomaf MBP	
[°F]	14	131	90	131											
[°C]	-10	45	20	45	784,8	2680	675,4	1,69	5,76	1,45	465,6	2,47	18,37	EN12900 MBP	
[°F]	14	113	68	113											

Performance tables

R134a, 230V/60Hz, CSIR, fan 3m/s, VDE, CCC, EAC, KC

	pe		Cooling capacity			COP	EER	P1	I	m	
	[°C]	[°F]	[W]	[Btu/h]	[kcal/h]	[W/W]	[Btu/Wh]	[kcal/Wh]	[W]	[A]	[kg/h]
[°C / °F]	-25	-13	346,8	1184	298,5	1,15	3,94	0,99	300,8	1,90	7,51
cond. pressure	-23	-10	389,3	1330	335,1	1,22	4,16	1,05	319,8	1,96	8,44
pc= 45/113	-20	-4	479,5	1638	412,7	1,34	4,59	1,16	356,7	2,08	10,42
return gas temp.	-18	0	545,3	1862	469,3	1,43	4,89	1,23	381,1	2,17	11,86
RGT= 32/90	-15	5	635,4	2170	546,9	1,54	5,27	1,33	411,9	2,27	13,85
liquid temp	-10	14	814,2	2781	700,7	1,75	5,97	1,51	465,6	2,47	17,82
Tliq= 45/113	-5	23	1015,5	3468	874,0	1,97	6,71	1,69	516,6	2,67	22,33
[°C / °F]	-25	-13	262,0	895	225,5	0,79	2,71	0,68	330,2	1,99	6,27
cond. pressure	-23	-10	298,2	1018	256,6	0,85	2,91	0,73	349,7	2,05	7,14
pc= 55/131	-20	-4	376,5	1286	324,0	0,97	3,31	0,83	388,0	2,17	9,03
return gas temp	-18	0	434,4	1484	373,9	1,05	3,59	0,90	413,8	2,25	10,44
RGT= 32/90	-15	5	514,9	1759	443,1	1,15	3,94	0,99	446,8	2,37	12,40
liquid temp	-10	14	677,1	2312	582,7	1,34	4,57	1,15	505,6	2,59	16,37
Tliq= 55/131	-5	23	862,5	2946	742,3	1,53	5,23	1,32	563,3	2,82	20,97

Model

Designation	SC15G	220-240V/50Hz	Conf. 3	Sales code:	104G8520
-------------	--------------	----------------------	----------------	-------------	-----------------

Configuration

Motorconfiguration	CSIR
Power supply (nominal)	220-240V/50Hz 1~
Refrigerant	R513A
Application	LBP+MBP+HBP
Voltage range	187-254V
Starting torque	HST
Approvals	VDE CCC UL

Electrical accessories / wiring diagram



Ambient/ machine room temperatures minimum /maximum

Ambient temperature range:	10 - 43°C / 50 - 110°F
Machine room temperature range:	10 - 48°C / 50 - 119°F
Compressor cooling:	fan 3m/s

Operation Limits

Operation pressure range



Components

a2	relay	117U6005
c	start capacitor (80μF)	117U5017
d	cord relief	103N1004
b	plastic cover	103N2009

Model

Designation **SC15G** **220-240V/50Hz** Conf. 3 Sales code: **104G8520**

Optimization + standard conditions

R513A, 220V/50Hz, CSIR, fan 3m/s, VDE, CCC, UL

		Evaporating pressure (saturation temperature)				Condensing pressure (saturation temperature)						Power consumption			
		Return gas temp.		Liquid temp.		Cooling capacity		COP	EER		P1	I	Ref. mass flow		
		pe	pc	RGT	Tliq	[W]	[Btu/h]	[kcal/h]	[W/W]	[Btu/Wh]	[kcal/Wh]	[W]	[A]	[kg/h]	
[°C]	[°F]	[°C]	[°F]	[°C]	[°F]										
-23	54	32	32	338,2	1155	291,1	1,13	3,87	0,98	298,2	2,70	7,28	ASHRAE LBP		
-10	130	90	90												
-25	55	32	55	232,3	793	199,9	0,83	2,84	0,71	279,8	2,67	6,36	cecomaf LBP		
-13	131	90	131												
-35	40	20	40	158,9	543	136,8	0,80	2,72	0,69	199,3	2,60	3,93	EN12900 LBP		
-31	104	68	104												
-7	54	35	46	780,5	2666	671,7	1,55	5,30	1,34	502,5	3,26	19,12	ASHRAE MBP		
20	130	95	115												
-10	55	32	55	588,4	2010	506,4	1,27	4,33	1,09	464,2	3,14	16,27	cecomaf MBP		
14	131	90	131												
-10	45	20	45	674,4	2303	580,4	1,56	5,33	1,34	431,8	3,04	17,87	EN12900 MBP		
14	113	68	113												

Performance tables

R513A, 220V/50Hz, CSIR, fan 3m/s, VDE, CCC, UL

	pe		Cooling capacity			COP	EER	P1	I	m	
	[°C]	[°F]	[W]	[Btu/h]	[kcal/h]	[W/W]	[Btu/Wh]	[kcal/Wh]	[W]	[A]	[kg/h]
[°C / °F]	-25	-13	297,5	1016	256,0	1,10	3,76	0,95	270,0	2,65	7,25
cond. pressure	-20	-4	410,1	1401	353,0	1,28	4,37	1,10	320,5	2,75	10,02
pc= 45/113	-10	14	705,2	2408	606,9	1,63	5,58	1,41	431,8	3,04	17,34
return gas temp.	-5	23	889,6	3038	765,6	1,83	6,24	1,57	487,0	3,21	21,96
RGT= 32/90	0	32	1100,0	3757	946,7	2,04	6,98	1,76	538,1	3,38	27,28
liquid temp	5	41	1337,3	4567	1150,9	2,30	7,84	1,98	582,3	3,54	33,35
Tliq= 45/113	15	59	1896,6	6477	1632,2	2,97	10,14	2,56	638,6	3,76	47,98
[°C / °F]	-25	-13	232,3	793	199,9	0,83	2,84	0,71	279,8	2,67	6,36
cond. pressure	-20	-4	332,4	1135	286,1	0,98	3,35	0,84	339,1	2,80	9,13
pc= 55/131	-10	14	588,4	2010	506,4	1,27	4,33	1,09	464,2	3,14	16,27
return gas temp	-5	23	746,4	2549	642,4	1,42	4,86	1,23	524,3	3,34	20,73
RGT= 32/90	0	32	925,6	3161	796,6	1,60	5,46	1,38	579,0	3,52	25,85
liquid temp	5	41	1127,2	3849	970,1	1,80	6,16	1,55	625,4	3,70	31,68
Tliq= 55/131	15	59	1601,0	5468	1377,8	2,35	8,02	2,02	682,2	3,95	45,72

Model

Designation	SC15G	208-230V/60Hz	Conf. 4	Sales code:	104G8520
-------------	--------------	----------------------	----------------	-------------	-----------------

Configuration

Motorconfiguration	CSIR
Power supply (nominal)	208-230V/60Hz 1~
Refrigerant	R513A
Application	LBP
Voltage range	198-254V
Starting torque	HST
Approvals	VDE CCC UL

Electrical accessories / wiring diagram

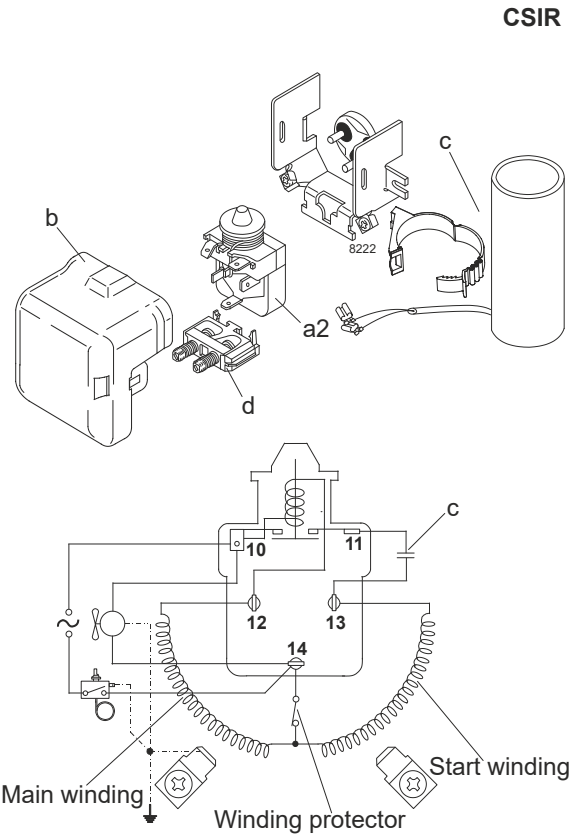

Ambient/ machine room temperatures minimum /maximum

Ambient temperature range:	10 - 43°C / 50 - 110°F
Machine room temperature range:	10 - 48°C / 50 - 119°F
Compressor cooling:	fan 3m/s

Operation Limits

Operation pressure range

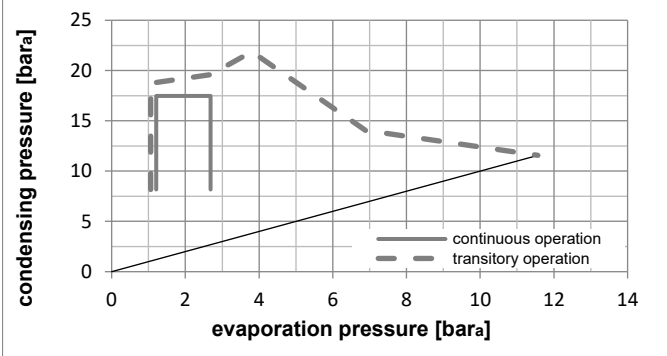
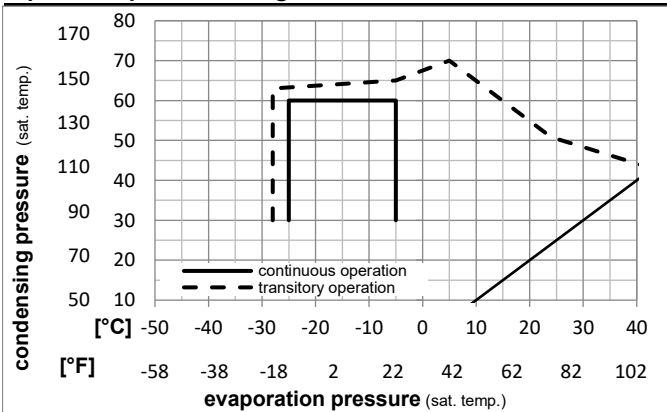

Components

a2	relay	117U6005
c	start capacitor (80μF)	117U5017
d	cord relief	103N1004
b	plastic cover	103N2009

Model

Designation **SC15G** **208-230V/60Hz** Conf. 4 Sales code: **104G8520**

Optimization + standard conditions

R513A, 230V/60Hz, CSIR, fan 3m/s, VDE, CCC, UL

		Evaporating pressure (saturation temperature)				Condensing pressure (saturation temperature)					Power consumption				
		Return gas temp.			Liquid temp.		Cooling capacity			COP	EER	Current consumption		Ref. mass flow	
		pe	pc	RGT	Tliq	[W]	[Btu/h]	[kcal/h]	[W/W]	[Btu/Wh]	[kcal/Wh]	P1	I	m	
[°C]	[°F]	[°C]	[°F]	[°C]	[°C]							[W]	[A]	[kg/h]	
-23	-10	54	130	32	90	411,6	1406	354,2	1,07	3,67	0,92	383,1	2,19	8,86	ASHRAE LBP
-25	-13	55	131	32	90	284,0	970	244,4	0,77	2,65	0,67	366,7	2,13	7,78	cecomaf LBP
-35	-31	40	104	20	68	187,8	641	161,6	0,94	3,21	0,81	199,6	1,47	4,65	EN12900 LBP
-7	20	54	130	35	95	928,2	3170	798,8	1,61	5,49	1,38	577,4	2,95	22,74	ASHRAE MBP
-10	14	55	131	32	90	702,6	2400	604,7	1,29	4,42	1,11	542,7	2,81	19,43	cecomaf MBP
-10	14	45	113	20	68	820,4	2802	706,0	1,65	5,63	1,42	497,9	2,64	21,74	EN12900 MBP

Performance tables

R513A, 230V/60Hz, CSIR, fan 3m/s, VDE, CCC, UL

	pe		Cooling capacity			COP	EER	P1			I	m
	[°C]	[°F]	[W]	[Btu/h]	[kcal/h]	[W/W]	[Btu/Wh]	[kcal/Wh]	[W]	[A]	[kg/h]	
[°C / °F]	-25	-13	378,7	1293	325,9	1,15	3,92	0,99	330,2	1,98	9,23	
cond. pressure	-23	-10	423,0	1445	364,1	1,21	4,13	1,04	349,7	2,06	10,32	
pc= 45/113	-20	-4	516,5	1764	444,5	1,33	4,55	1,15	387,4	2,21	12,62	
return gas temp.	-18	0	584,1	1995	502,7	1,42	4,84	1,22	412,4	2,30	14,29	
RGT= 32/90	-15	5	676,3	2310	582,1	1,52	5,21	1,31	443,7	2,43	16,57	
liquid temp	-10	14	857,8	2930	738,3	1,72	5,88	1,48	497,9	2,64	21,09	
Tliq= 45/113	-5	23	1060,6	3622	912,7	1,93	6,60	1,66	549,1	2,84	26,18	
[°C / °F]	-25	-13	284,0	970	244,4	0,77	2,65	0,67	366,7	2,13	7,78	
cond. pressure	-23	-10	321,2	1097	276,4	0,83	2,84	0,72	386,3	2,20	8,80	
pc= 55/131	-20	-4	401,0	1369	345,1	0,94	3,22	0,81	424,9	2,35	11,01	
return gas temp	-18	0	459,7	1570	395,6	1,02	3,48	0,88	450,8	2,45	12,64	
RGT= 32/90	-15	5	540,7	1847	465,3	1,12	3,82	0,96	483,9	2,58	14,89	
liquid temp	-10	14	702,6	2400	604,7	1,29	4,42	1,11	542,7	2,81	19,43	
Tliq= 55/131	-5	23	886,4	3027	762,8	1,48	5,04	1,27	600,3	3,04	24,62	



SC Compressors





SC Compressors

Service/Repair – R290



8545



Secop accepts no responsibility for possible errors in catalogs, brochures, and other printed material. Secop reserves the right to alter its products without notice. This also applies to products already on order provided that such alterations can be made without subsequent changes being necessary to specifications already agreed. All trademarks in this material are the property of the respective companies. Secop and the Secop logotype are trademarks of Secop GmbH. All rights reserved. www.secop.com