

Single Pack TL4CNX.2 115V 60Hz CSIR

Single pack code number: **195B4432**

Position	Title	Code	Amount
1	Compressor TL4CNX.2	102H3490	1
2	Starting relay	117U7005	1
3	Starting capacitor (240 μ F 125V, 6.3mm)	117U5023	1
4	Cord relief	103N1010	1
5	Cover	103N2011	1
6	Bolt joint for one compressor 1/4" \varnothing 19mm	118-1949	1

Secop GmbH • Lise-Meitner-Straße 29 • 24941 Flensburg, Germany • Tel: +49 461 4941 0 • www.secop.com

Secop accepts no responsibility for possible errors in catalogs, brochures, and other printed material. Secop reserves the right to alter its products without notice. This also applies to products already on order provided that such alterations can be made without subsequent changes being necessary to specifications already agreed. All trademarks in this material are the property of the respective companies. Secop and the Secop logotype are trademarks of Secop GmbH. All rights reserved.

TL4CNX.2 LBP/MBP Compressor R290 115V 60Hz

General

Code number	102H3490
Approvals	UL984
Compressors on pallet	125

Application

Application	LBP/MBP			
Frequency	Hz	50	60	
Evaporating temperature	°F	-	-40 to 45	
Voltage range	V	-	95 - 135	
Max. condensing temperature continuous (short)	°F	-	131 (149)	
Max. winding temperature continuous (short)	°F	-	257 (275)	

Cooling requirements

Frequency	Hz	50			60		
Application		LBP	MBP	HBP	LBP	MBP	HBP
90°F		-	-	-	F ₂	F ₂	-
100°F		-	-	-	F ₂	F ₂	-
110°F		-	-	-	F ₂	F ₂	-
Remarks on application:							

Motor

Motor type	CSIR		
LRA (rated after 4 sec. UL984), HST LST	A	18.5	-
Cut in Current, HST LST	A	18.5	-
Resistance, main start winding (77°F)	Ω	2.7	6.1

Design

Displacement	cu.in	0.29
Oil quantity (type)	fl.oz.	9.5 (polyolester)
Maximum refrigerant charge	oz.	5.3
Free gas volume in compressor	fl.oz.	54.1
Weight without electrical equipment	lbs.	16.5

Dimensions

Height	inch	A	6.81
		B	6.65
		B1	-
		B2	-
Suction connector	location, I.D. in. angle	C	0.252-0.259 30°
	material comment		Copper Rubber plug
Process connector	location, I.D. in. angle	D	0.252-0.259 31.5°
	material comment		Copper Rubber plug
Discharge connector	location, I.D. in. angle	E	0.189-0.193 28°
	material comment		Copper Rubber plug
Oil cooler connector	location, I.D. in. angle	F	-
	material comment		-
Remarks:			

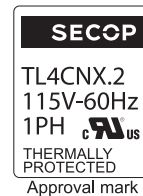
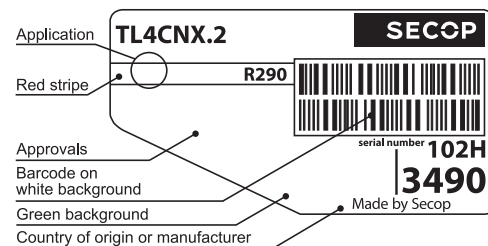

- S = Static cooling normally sufficient
- O = Oil cooling
- F₁ = Fan cooling 1.5 m/s
(compressor compartment temperature equal to ambient temperature)
- F₂ = Fan cooling 3.0 m/s necessary
- SG = Suction gas cooling normally sufficient
- = not applicable in this area

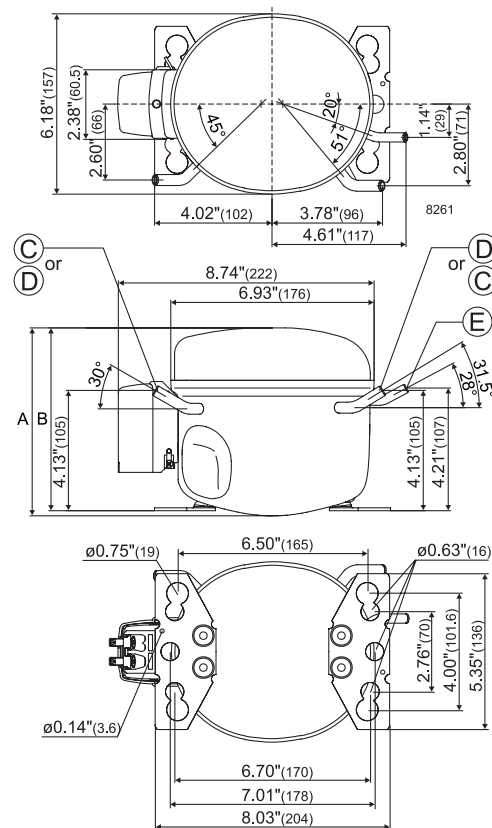

ASHRAE LBP

115V, 60Hz, fan cooling F₂

Evap. temp. in °F	-49	-40	-30	-20	-13	-10	0	10	14	20	30	32	40	41	45	50	59
Capacity in BTU/h		237	380	539	664	722	936	1190	1305	1492	1850	1928	2271	2086	2509		
Power cons. in W		114	132	150	162	168	185	202	209	218	233	236	247	248	253		
Current cons. in A		2.06	2.13	2.22	2.29	2.32	2.43	2.55	2.59	2.66	2.77	2.79	2.87	2.88	2.92		
EER in BTU/Wh		2.07	2.88	3.60	4.09	4.31	5.05	5.89	6.25	6.83	7.93	8.17	9.21	8.42	9.93		

ASHRAE MBP/HBP

115V, 60Hz, fan cooling F₂

Evap. temp. in °F	-49	-40	-30	-20	-13	-10	0	10	14	20	30	32	40	41	45	50	59
Capacity in BTU/h		214	343	486	599	651	845	1074	1177	1345	1666	1737	2045	2086	2258		
Power cons. in W		114	132	150	162	168	185	202	209	218	233	236	247	248	253		
Current cons. in A		2.06	2.13	2.22	2.29	2.32	2.43	2.55	2.59	2.66	2.77	2.79	2.87	2.88	2.92		
EER in BTU/Wh		1.87	2.60	3.25	3.69	3.89	4.56	5.31	5.63	6.16	7.14	7.36	8.29	8.42	8.94		

EN 12900 Household (CECOMAF)* 115V, 60Hz, fan cooling F₂

Evap. temp. in °F	-49	-40	-30	-20	-13	-10	0	10	14	20	30	32	40	41	45	50	59
Capacity in W		82	114	153	185	200	257	325	356	407	504	526	618	631	682		
Power cons. in W		118	132	147	157	161	175	189	194	201	213	215	223	223	227		
Current cons. in A		2.08	2.14	2.20	2.26	2.28	2.37	2.46	2.49	2.54	2.63	2.64	2.70	2.71	2.73		
COP in W/W		0.69	0.87	1.05	1.18	1.24	1.47	1.72	1.84	2.02	2.37	2.45	2.78	2.82	3.01		

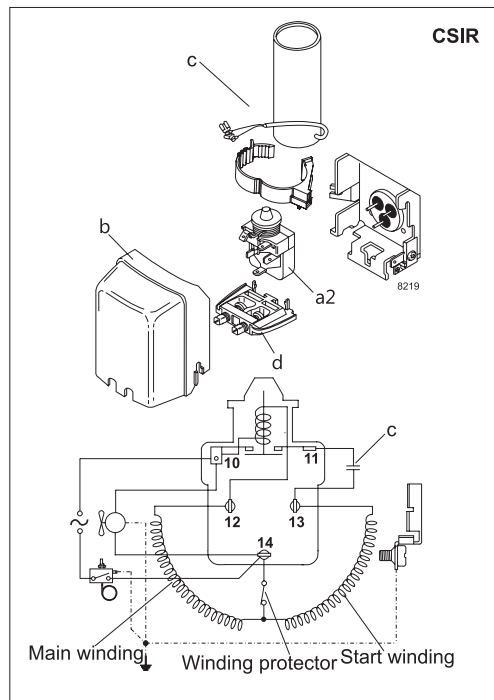

Accessories for	TL4CNX.2	Figure	Code number	Test conditions	ASHRAE LBP	ASHRAE MBP/HBP	EN 12900/CECOMAF*
PTC starting device	1/4 in. spade connect.	a1	–	Condensing temp.	130°F	130°F	113°F
	3/16 in. spade connect.		–	Ambient temp.	90°F	90°F	90°F
Starting relay	1/4 in. spade connect.	a2	117U7005	Suction gas temp.	90°F	95°F	90°F
Cover		b	103N2011	Liquid temperature	90°F	115°F	no subcooling
Start. capacitor 240 µF	1/4 in. spade connect.	c	117U5023				
Cord relief		d	103N1010				
Mounting accessories					Code number		
Bolt joint for one comp.					Ø: 5/8 in.	118-1917	
Bolt joint in quantities					Ø: 5/8 in.	118-1918	
Snap-on in quantities					Ø: 5/8 in.	118-1919	

Secop accepts no responsibility for possible errors in catalogs, brochures, and other printed material. Secop reserves the right to alter its products without notice. This also applies to products already on order provided that such alterations can be made without consequential changes being necessary to specifications already agreed. All trademarks in this material are the property of the respective companies. Secop and the Secop logotype are trademarks of Secop GmbH. All rights reserved. www.secop.com



TL Compressors

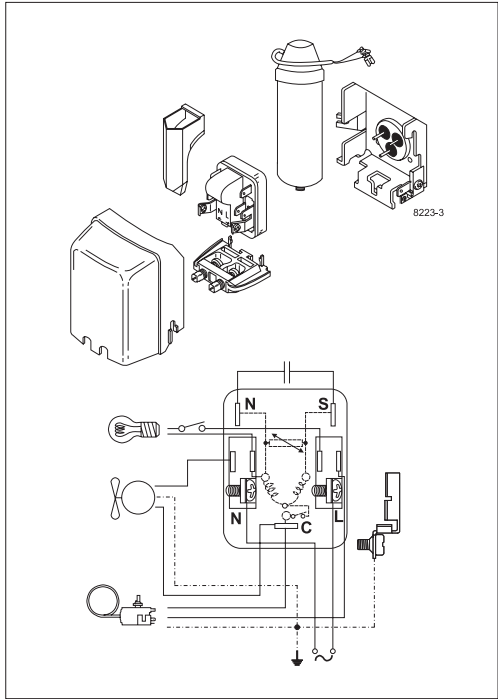
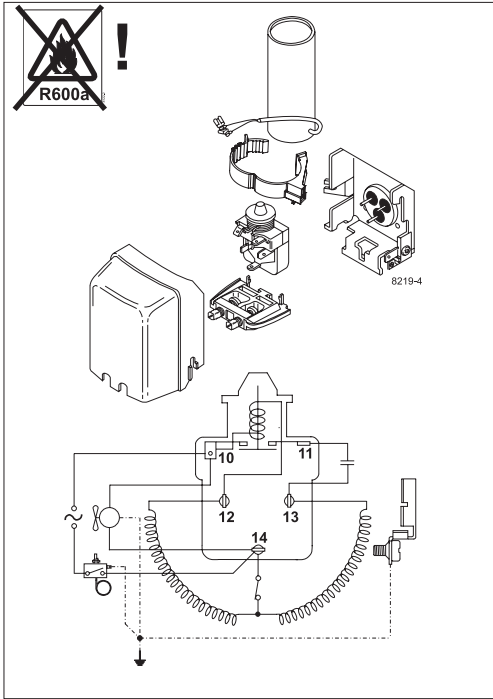



Service/Repair – R600a, R290



8545

Brazing on Suction Connectors (Direct Intake)

representative image



**! max. 150°C/302°F !
at socket**
brazing solder: phosphor (LP7) or silver

Refer to Product Bulletin:
**Brazing on Suction Connectors
(Compressors with Direct Suction Intake)**

Secop accepts no responsibility for possible errors in catalogs, brochures, and other printed material. Secop reserves the right to alter its products without notice. This also applies to products already on order provided that such alterations can be made without subsequential changes being necessary to specifications already agreed. All trademarks in this material are the property of the respective companies. Secop and the Secop logotype are trademarks of Secop GmbH. All rights reserved. www.secop.com