

Single Pack NL6FT 220-240V 50/60Hz CSIR

Single pack code number: **195B4492**

Position	Title	Code	Amount
1	Compressor NL6FT	105G6628	1
2	Starting relay	117U6000	1
3	Starting capacitor (80 μ F 220V, 6.3mm)	117U5015	1
4	Cord relief	103N1010	1
5	Cover	103N2010	1
6	Bolt joint for one compressor M6 \varnothing 16mm	118-1917	1

Secop GmbH • Lise-Meitner-Straße 29 • 24941 Flensburg, Germany • Tel: +49 461 4941 0 • www.secop.com

Secop accepts no responsibility for possible errors in catalogs, brochures, and other printed material. Secop reserves the right to alter its products without notice. This also applies to products already on order provided that such alterations can be made without subsequent changes being necessary to specifications already agreed. All trademarks in this material are the property of the respective companies. Secop and the Secop logotype are trademarks of Secop GmbH. All rights reserved.

Model

Designation	NL6FT	220-240V/50Hz 1~ 220-240V/60Hz 1~	Sales code:	105G6628
-------------	--------------	--	-------------	-----------------

Compressor design

Oil type	Polyolester	Refrigerant(s)	R134a
Oil viscosity	19,2cST	Displacement	6,13cm ³ / 0,37cu.in
Oil quantity	265cm ³ / 9fl.oz	Compressors on pallet	80
Refr. charge - tech. limit	400g / 14,1oz		
Free gas volume comp.	2360cm ³ / 79,8fl.oz		
Weight	10kg / 22lbs		
Motor protection	1# internal		
Winding resistance main	12,6Ω (at 25°C)		
Winding resistance aux	12,4Ω (at 25°C)		
Max. winding temp.	125°C / 257°F		
Max. discharge temp.	130°C / 266°F		



General - Configurations with NL6FT

	Conf. 1	Conf. 2	Conf. 3	Conf. 4
Motorconfiguration	CSIR	CSIR	RSIR	RSIR
Power supply (nominal)	220-240V/50Hz	208-230V/60Hz	220-240V/50Hz	208-230V/60Hz
Number of phases	1	1	1	1
Voltage range	187-254V	198-254V	187-254V	198-254V
Approvals	VDE, EAC	VDE, EAC	VDE, EAC	VDE, EAC
Starting torque	HST	HST	LST	LST
Note	- / -			

Applications with NL6FT

	Conf. 1	Conf. 2	Conf. 3	Conf. 4
Refrigerant	R134a	R134a	R134a	R134a
Application	LBP	LBP	LBP	LBP
System cooling	static	static	static	static
Hot gas defrost	- / -	- / -	- / -	- / -
Long interval pull down	- / -	- / -	- / -	- / -

Electrical data - Configurations with NL6FT

	Conf. 1	Conf. 2	Conf. 3	Conf. 4
Starting device type	relay	relay	PTC	PTC
Run capacitor	- / -	- / -	- / -	- / -
Start capacitor	80μF	80μF	- / -	- / -
LRA (locked rotor amps / 4s)	7,5A	7,5A	5,8A	5,8A
RLA (rated load amps / 1s)	1,2A	1,2A	1,2A	1,2A
Cut in current	10,5A	10,5A	10,5A	10,5A

Model

Designation **NL6FT** 220-240V/50Hz 1~ 220-240V/60Hz 1~ Sales code: **105G6628**

Compressor dimensions

Housing	A Height	197mm / 7,76in
	B Height	191mm / 7,52in
	C Length shell	230mm / 9,06in
	D Length w. cover	254mm / 10in
	E Width	166mm / 6,54in

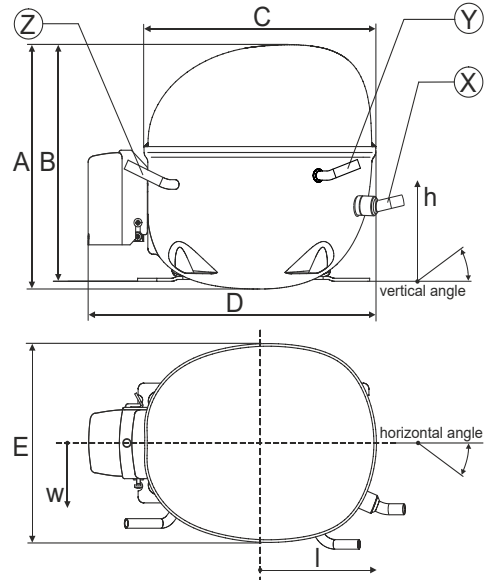

Connectors		Suction	Discharge	Process
		X	Y	Z
Diameter	[mm]	øi 6,11-6,29	øi 5,12-5,22	øi 6,11-6,29
	(i:inside, o:outside) [in]	øi 0,24-0,25	øi 0,2-0,21	øi 0,24-0,25
Material		copper	copper	copper
Horizontal angle	±2°	0°	0°	0°
Vertical angle	±2°	15°	35°	155°
Position l/h/w	[mm]	126/76/78	133/103/54	-107/94/72
	[in]	4,9/3/3,1	5,2/4/2,1	-4,2/3,7/2,8
Straight tube l.	[mm]	12	12	12
	[in]	0,5	0,5	0,5

Compressor fixation

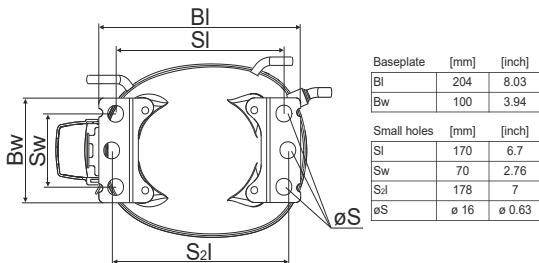

Bolt joint

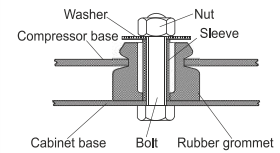

Snap-on

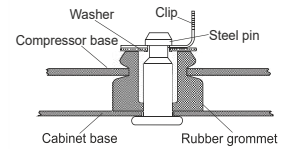

Mounting accessories	one comp.	multi pack
Bolt joint M6 ø16mm	118-1917	118-1918
Bolt joint ø1/4" ø16mm	118-1946	
Bolt joint ø1/4" ø19mm	118-1949	
Snap-on ø7,3 ø16mm	118-1947	118-1919

Model

Designation	NL6FT	220-240V/50Hz	Conf. 1	Sales code:	105G6628
-------------	--------------	----------------------	----------------	-------------	-----------------

Configuration

Motorconfiguration	CSIR
Power supply (nominal)	220-240V/50Hz 1~
Refrigerant	R134a
Application	LBP
Voltage range	187-254V
Starting torque	HST
Approvals	VDE EAC

Electrical accessories / wiring diagram

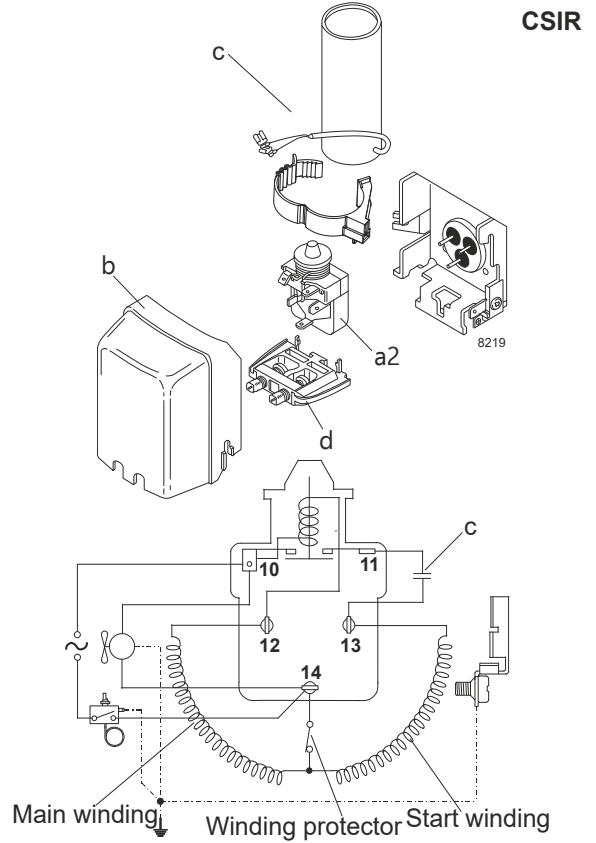

Ambient temperatures / system cooling

Ambient temperature min.:	10°C / 50°F
Ambient temperature max.:	43°C / 110°F

System cooling (n/a: outside limits)			
T ambient	LBP	MBP	HBP
32°C / 90°F	static	n/a	n/a
38°C / 100°F	static	n/a	n/a
43°C / 110°F	static	n/a	n/a

Operation pressure range

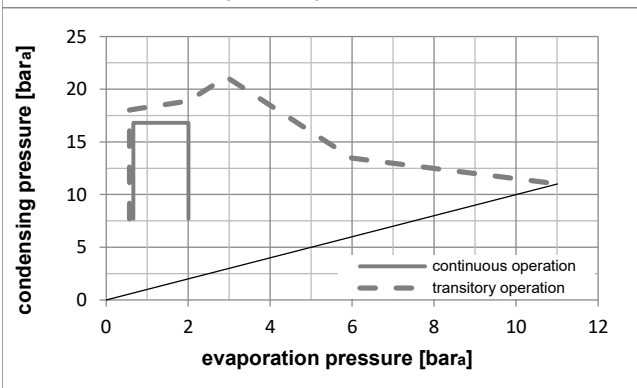
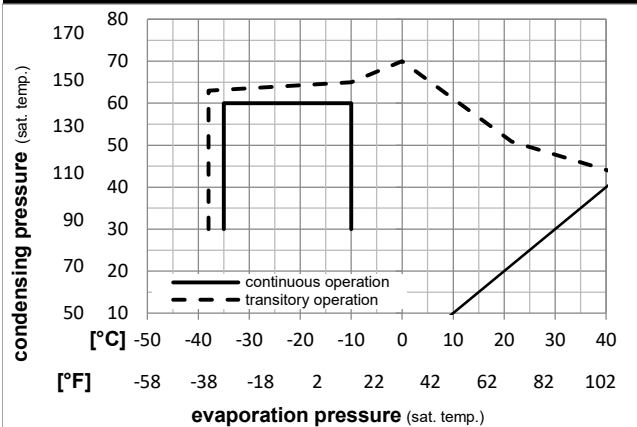

Components

a2	relay	117U6000
c	start capacitor (80µF)	117U5015
b	plastic cover	103N2010
d	cord relief	103N1010

Alternative components

b	plastic cover	103N2011
---	---------------	----------

Model

Designation	NL6FT	220-240V/50Hz	Conf. 1	Sales code:	105G6628
-------------	--------------	----------------------	----------------	-------------	-----------------

Optimization + standard conditions

R134a, 220V/50Hz, CSIR, static, VDE, EAC

		Evaporating pressure (saturation temperature)				Condensing pressure (saturation temperature)						Power consumption			
						Return gas temp.			Liquid temp.			Current consumption			Ref. mass flow
						Cooling capacity			COP	EER	P1			I	m
		pe	pc	RGT	Tliq	[W]	[Btu/h]	[kcal/h]	[W/W]	[Btu/Wh]	[kcal/Wh]	[W]	[A]	[kg/h]	
[°C]	-23,3	54,4	32,2	32,2	156,3	534	134,5	1,21	4,12	1,04	129,5	0,86	3,03	ASHRAE LBP	
[°F]	-10	130	90	90											
[°C]	-25	55	32	55	114,9	392	98,9	0,93	3,18	0,80	123,3	0,84	2,75	cecomaf LBP	
[°F]	-13	131	89,6	131											
[°C]	-35	40	20	40	80,0	273	68,9	0,87	2,98	0,75	91,7	0,77	1,76	EN12900 LBP	
[°F]	-31	104	68	104											
[°C]	-23,3	48,9	4,44	48,9	128,8	440	110,8	1,00	3,41	0,86	128,8	0,87	3,40	ARI540 LBP	
[°F]	-10	120	40	120											
[°C]	-23,3	40,6	32,2	32,2	175,8	601	151,3	1,41	4,82	1,22	124,5	0,86	3,41	AHAM LBP	
[°F]	-10	105	90	90											
[°C]	-35	45	32	45	74,8	256	64,4	0,81	2,75	0,69	92,9	0,78	1,61	opt	
[°F]	-31	113	89,6	113											

Performance tables

R134a, 220V/50Hz, CSIR, static, VDE, EAC

	pe	Cooling capacity				COP			EER			P1	I	m
	[°C]	[°F]	[W]	[Btu/h]	[kcal/h]	[W/W]	[Btu/Wh]	[kcal/Wh]	[W]	[A]	[kg/h]			
[°C / °F]	-35	-31	74,8	256	64,4	0,81	2,75	0,69	92,9	0,78	1,61			
cond. pressure	-30	-22	103,1	352	88,7	0,97	3,32	0,84	106,0	0,81	2,23			
pc= 45/113	-25	-13	138,3	472	119,1	1,14	3,89	0,98	121,4	0,85	3,00			
return gas temp.	-23,3	-10	152,1	519	130,9	1,20	4,09	1,03	127,1	0,87	3,30			
RGT= 32/90	-20	-4	181,6	620	156,3	1,31	4,48	1,13	138,5	0,90	3,95			
liquid temp	-15	5	233,8	799	201,2	1,49	5,10	1,29	156,5	0,96	5,10			
Tliq= 45/113	-10	14	296,0	1011	254,7	1,69	5,78	1,46	174,9	1,03	6,48			
[°C / °F]	-35	-31	60,1	205	51,7	0,65	2,21	0,56	92,7	0,77	1,43			
cond. pressure	-30	-22	84,4	288	72,7	0,79	2,71	0,68	106,6	0,80	2,01			
pc= 55/131	-25	-13	114,9	392	98,9	0,93	3,18	0,80	123,3	0,84	2,75			
return gas temp	-23,3	-10	126,8	433	109,2	0,98	3,34	0,84	129,5	0,85	3,04			
RGT= 32/90	-20	-4	152,4	521	131,2	1,07	3,66	0,92	142,2	0,89	3,66			
liquid temp	-15	5	198,0	676	170,4	1,22	4,16	1,05	162,7	0,96	4,77			
Tliq= 55/131	-10	14	252,5	862	217,3	1,37	4,69	1,18	184,1	1,04	6,11			

Model

Designation	NL6FT	208-230V/60Hz	Conf. 2	Sales code:	105G6628
-------------	--------------	----------------------	----------------	-------------	-----------------

Configuration

Motorconfiguration	CSIR
Power supply (nominal)	208-230V/60Hz 1~
Refrigerant	R134a
Application	LBP
Voltage range	198-254V
Starting torque	HST
Approvals	VDE EAC

Electrical accessories / wiring diagram

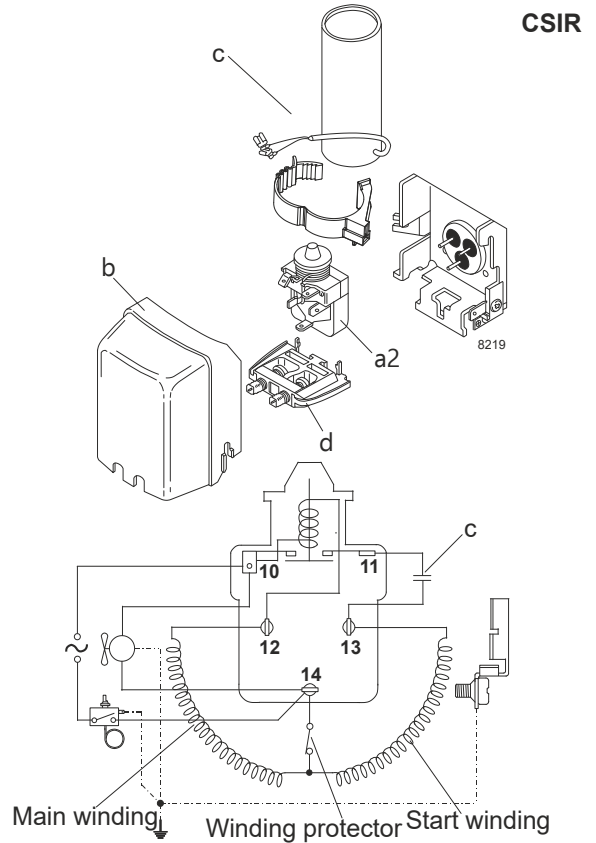

Ambient temperatures / system cooling

Ambient temperature min.:	10°C / 50°F
Ambient temperature max.:	43°C / 110°F

System cooling (n/a: outside limits)			
T ambient	LBP	MBP	HBP
32°C / 90°F	static	n/a	n/a
38°C / 100°F	static	n/a	n/a
43°C / 110°F	static	n/a	n/a

Operation pressure range

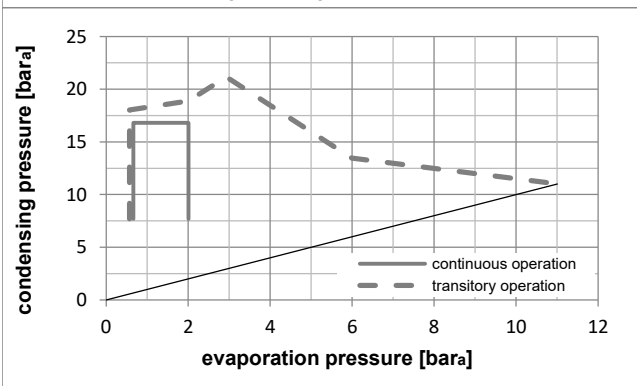
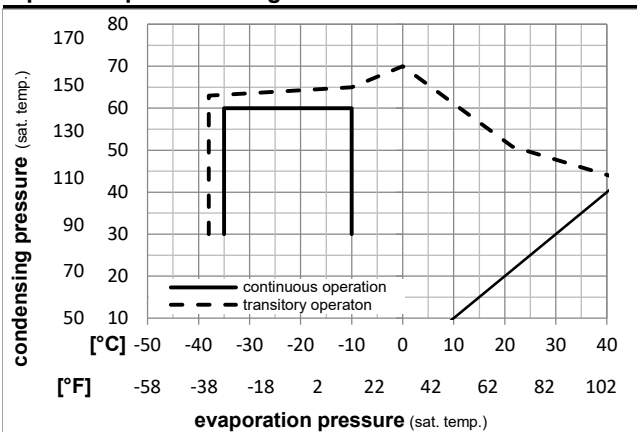

Components

a2	relay	117U6000
c	start capacitor (80µF)	117U5015
b	plastic cover	103N2010
d	cord relief	103N1010

Alternative components

b	plastic cover	103N2011
---	---------------	----------

Model

Designation **NL6FT 208-230V/60Hz** Conf. 2 Sales code: **105G6628**

Optimization + standard conditions

R134a, 220V/60Hz, CSIR, static, VDE, EAC

Evaporating pressure (saturation temperature)		Condensing pressure (saturation temperature)				Cooling capacity						Power consumption		Ref. mass flow m	
		Return gas temp.				COP		EER		P1	I				
		Liquid temp.				[W]	[Btu/h]	[kcal/h]	[W/W]	[Btu/Wh]	[kcal/Wh]	[W]	[A]	[kg/h]	
pe	pc	RGT	Tliq												
[°C]	-23	54,4	32,2	32,2	161,3	551	138,8	1,22	4,16	1,05	132,4	0,91	3,13	ASHRAE LBP	
[°F]	-10	130	90	90											
[°C]	-25	55	32	55	119,0	406	102,4	0,94	3,22	0,81	126,1	0,90	2,85	cecomaf LBP	
[°F]	-13	131	89,6	131											
[°C]	-35	40	20	40	78,2	267	67,3	0,90	3,09	0,78	86,5	0,81	1,72	EN12900 LBP	
[°F]	-31	104	68	104											
[°C]	-23	48,9	4,44	48,9	132,5	452	114,0	1,01	3,44	0,87	131,6	0,91	3,50	ARI540 LBP	
[°F]	-10	120	40	120											
[°C]	-23	40,6	32,2	32,2	180,0	615	154,9	1,41	4,81	1,21	127,8	0,90	3,50	AHAM LBP	
[°F]	-10	105	90	90											
[°C]	-35	45	32	45	73,2	250	63,0	0,84	2,86	0,72	87,4	0,82	1,58	opt	
[°F]	-31	113	89,6	113											

Performance tables

R134a, 220V/60Hz, CSIR, static, VDE, EAC

	pe		Cooling capacity			COP		EER		P1	I	m
	[°C]	[°F]	[W]	[Btu/h]	[kcal/h]	[W/W]	[Btu/Wh]	[kcal/Wh]	[W]	[A]	[kg/h]	
[°C / °F]	-35	-31	73,2	250	63,0	0,84	2,86	0,72	87,4	0,82	1,58	
cond. pressure	-30	-22	105,6	361	90,9	0,99	3,38	0,85	106,7	0,86	2,28	
pc= 45/113	-25	-13	142,3	486	122,5	1,14	3,91	0,98	124,4	0,90	3,08	
return gas temp.	-23	-10	156,0	533	134,3	1,20	4,10	1,03	130,1	0,91	3,38	
RGT= 32/90	-20	-4	184,8	631	159,1	1,31	4,49	1,13	140,7	0,93	4,02	
liquid temp	-15	5	234,7	801	202,0	1,51	5,14	1,30	155,9	0,97	5,12	
Tliq= 45/113	-10	14	293,3	1002	252,4	1,72	5,88	1,48	170,3	1,01	6,42	
[°C / °F]	-35	-31	58,9	201	50,7	0,68	2,32	0,58	86,8	0,81	1,40	
cond. pressure	-30	-22	87,2	298	75,0	0,81	2,78	0,70	107,0	0,85	2,08	
pc= 55/131	-25	-13	119,0	406	102,4	0,94	3,22	0,81	126,1	0,90	2,85	
return gas temp	-23	-10	130,9	447	112,7	0,99	3,38	0,85	132,4	0,91	3,13	
RGT= 32/90	-20	-4	155,9	532	134,2	1,08	3,69	0,93	144,4	0,94	3,74	
liquid temp	-15	5	199,3	681	171,5	1,23	4,20	1,06	162,1	0,99	4,80	
Tliq= 55/131	-10	14	250,7	856	215,7	1,40	4,77	1,20	179,3	1,04	6,06	

Model

Designation	NL6FT	220-240V/50Hz	Conf. 3	Sales code:	105G6628
-------------	--------------	----------------------	----------------	-------------	-----------------

Configuration

Motorconfiguration	RSIR
Power supply (nominal)	220-240V/50Hz 1~
Refrigerant	R134a
Application	LBP
Voltage range	187-254V
Starting torque	LST
Approvals	VDE EAC

Electrical accessories / wiring diagram

RSIR

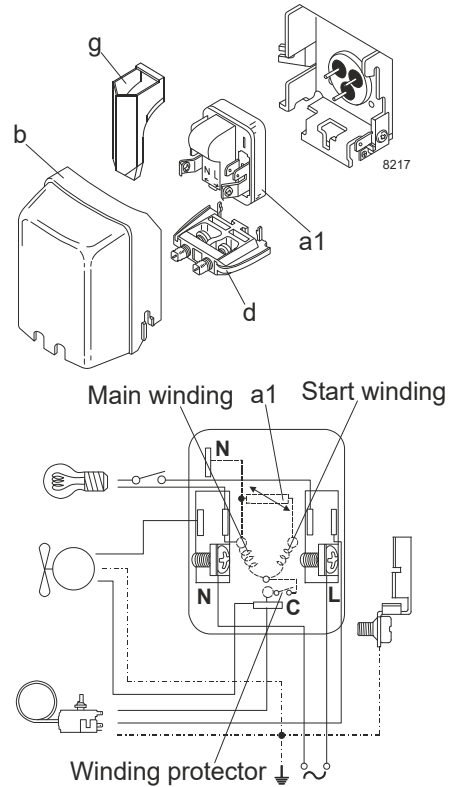

Ambient temperatures / system cooling

Ambient temperature min.:	10°C / 50°F
Ambient temperature max.:	43°C / 110°F

System cooling (n/a: outside limits)			
T ambient	LBP	MBP	HBP
32°C / 90°F	static	n/a	n/a
38°C / 100°F	static	n/a	n/a
43°C / 110°F	static	n/a	n/a

Operation pressure range

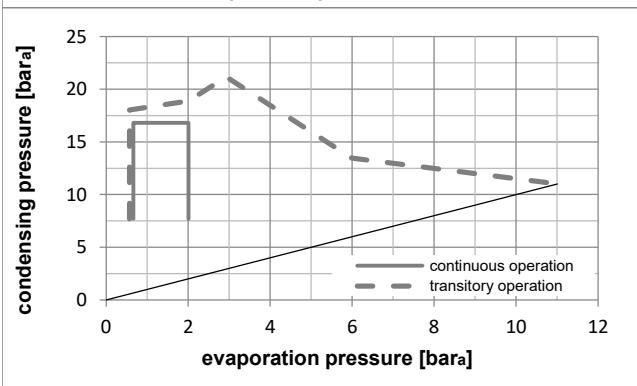
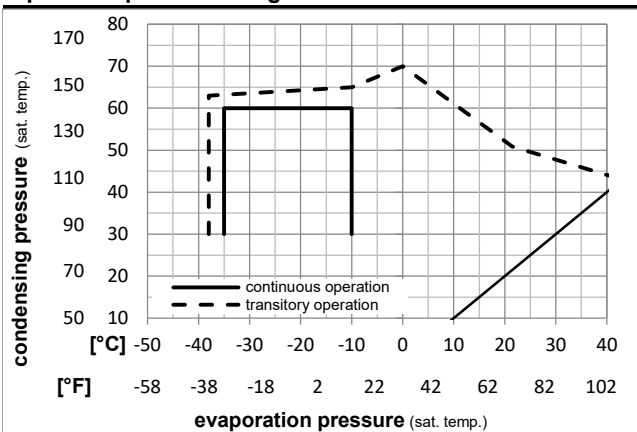

Components

a1	PTC starter (220V, 250hm, 4.8mm)	103N0018
b	plastic cover	103N2010
d	cord relief	103N1010
g	protection screen for PTC	103N0476

Alternative components

a1	PTC starter (220V, 250hm, 6.3mm)	103N0011
b	plastic cover	103N2011
d	cord relief	103N1010
g	protection screen for PTC	103N0476

Model

Designation	NL6FT	220-240V/50Hz	Conf. 3	Sales code:	105G6628
-------------	--------------	----------------------	----------------	-------------	-----------------

Optimization + standard conditions

R134a, 220V/50Hz, RSIR, static, VDE, EAC

		Evaporating pressure (saturation temperature)				Condensing pressure (saturation temperature)						Power consumption					
						Return gas temp.						Current consumption					
						Liquid temp.						Ref. mass flow					
						Cooling capacity						COP	EER	P1	I	m	
		pe	pc	RGT	Tliq	[W]	[Btu/h]	[kcal/h]	[W/W]	[Btu/Wh]	[kcal/Wh]	[W]	[A]	[kg/h]			
[°C]	-23,3	54,4	32,2	32,2	156,3	534	134,5	1,21	4,12	1,04	129,5	0,86	3,03	ASHRAE LBP			
[°F]	-10	130	90	90													
[°C]	-25	55	32	55	114,9	392	98,9	0,93	3,18	0,80	123,3	0,84	2,75	cecomaf LBP			
[°F]	-13	131	89,6	131													
[°C]	-35	40	20	40	80,0	273	68,9	0,87	2,98	0,75	91,7	0,77	1,76	EN12900 LBP			
[°F]	-31	104	68	104													
[°C]	-23,3	48,9	4,44	48,9	128,8	440	110,8	1,00	3,41	0,86	128,8	0,87	3,40	ARI540 LBP			
[°F]	-10	120	40	120													
[°C]	-23,3	40,6	32,2	32,2	175,8	601	151,3	1,41	4,82	1,22	124,5	0,86	3,41	AHAM LBP			
[°F]	-10	105	90	90													
[°C]	-35	45	32	45	74,8	256	64,4	0,81	2,75	0,69	92,9	0,78	1,61	opt			
[°F]	-31	113	89,6	113													

Performance tables

R134a, 220V/50Hz, RSIR, static, VDE, EAC

	pe	Cooling capacity				COP	EER	P1	I	m	
	[°C]	[°F]	[W]	[Btu/h]	[kcal/h]	[W/W]	[Btu/Wh]	[kcal/Wh]	[W]	[A]	[kg/h]
[°C / °F]	-35	-31	74,8	256	64,4	0,81	2,75	0,69	92,9	0,78	1,61
cond. pressure	-30	-22	103,1	352	88,7	0,97	3,32	0,84	106,0	0,81	2,23
pc= 45/113	-25	-13	138,3	472	119,1	1,14	3,89	0,98	121,4	0,85	3,00
return gas temp.	-23,3	-10	152,1	519	130,9	1,20	4,09	1,03	127,1	0,87	3,30
RGT= 32/90	-20	-4	181,6	620	156,3	1,31	4,48	1,13	138,5	0,90	3,95
liquid temp	-15	5	233,8	799	201,2	1,49	5,10	1,29	156,5	0,96	5,10
Tliq= 45/113	-10	14	296,0	1011	254,7	1,69	5,78	1,46	174,9	1,03	6,48
[°C / °F]	-35	-31	60,1	205	51,7	0,65	2,21	0,56	92,7	0,77	1,43
cond. pressure	-30	-22	84,4	288	72,7	0,79	2,71	0,68	106,6	0,80	2,01
pc= 55/131	-25	-13	114,9	392	98,9	0,93	3,18	0,80	123,3	0,84	2,75
return gas temp	-23,3	-10	126,8	433	109,2	0,98	3,34	0,84	129,5	0,85	3,04
RGT= 32/90	-20	-4	152,4	521	131,2	1,07	3,66	0,92	142,2	0,89	3,66
liquid temp	-15	5	198,0	676	170,4	1,22	4,16	1,05	162,7	0,96	4,77
Tliq= 55/131	-10	14	252,5	862	217,3	1,37	4,69	1,18	184,1	1,04	6,11

Model

Designation	NL6FT	208-230V/60Hz	Conf. 4	Sales code:	105G6628
-------------	--------------	----------------------	----------------	-------------	-----------------

Configuration

Motorconfiguration	RSIR
Power supply (nominal)	208-230V/60Hz 1~
Refrigerant	R134a
Application	LBP
Voltage range	198-254V
Starting torque	LST
Approvals	VDE EAC

Electrical accessories / wiring diagram

RSIR

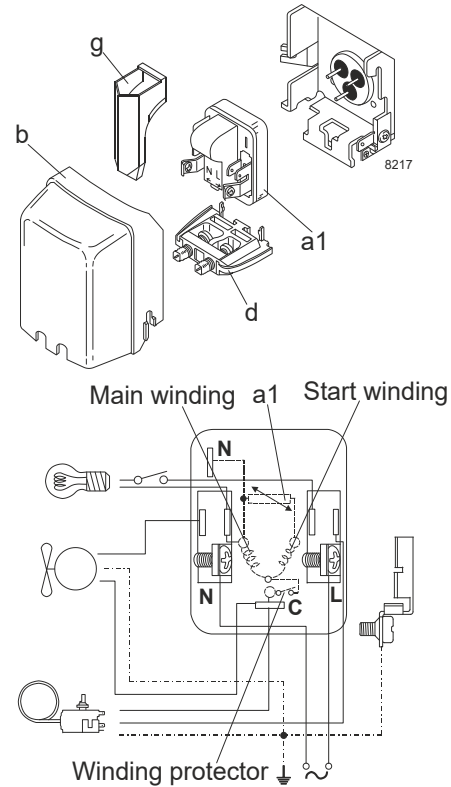

Ambient temperatures / system cooling

Ambient temperature min.:	10°C / 50°F
Ambient temperature max.:	43°C / 110°F

System cooling (n/a: outside limits)			
T ambient	LBP	MBP	HBP
32°C / 90°F	static	n/a	n/a
38°C / 100°F	static	n/a	n/a
43°C / 110°F	static	n/a	n/a

Operation pressure range

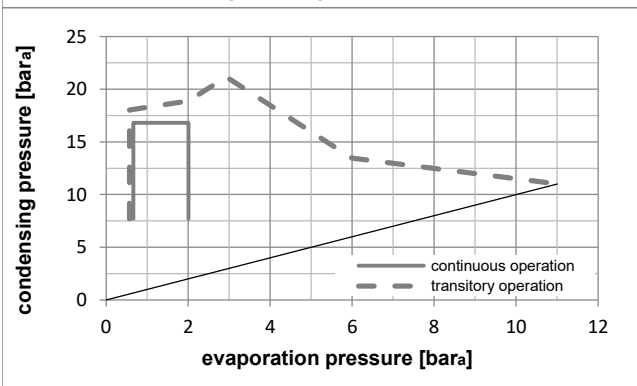
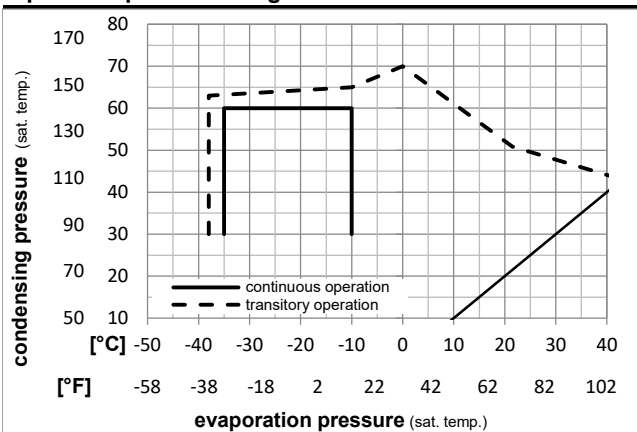

Components

a1	PTC starter (220V, 250hm, 4.8mm)	103N0018
b	plastic cover	103N2010
d	cord relief	103N1010
g	protection screen for PTC	103N0476

Alternative components

a1	PTC starter (220V, 250hm, 6.3mm)	103N0011
b	plastic cover	103N2011
d	cord relief	103N1010
g	protection screen for PTC	103N0476

Model

Designation	NL6FT	208-230V/60Hz	Conf. 4	Sales code:	105G6628
-------------	--------------	----------------------	----------------	-------------	-----------------

Optimization + standard conditions

R134a, 220V/60Hz, RSIR, static, VDE, EAC

		Evaporating pressure (saturation temperature)				Condensing pressure (saturation temperature)						Power consumption					
						Return gas temp.						Current consumption					
						Liquid temp.						Ref. mass flow					
						Cooling capacity						COP	EER	P1	I	m	
		pe	pc	RGT	Tliq	[W]	[Btu/h]	[kcal/h]	[W/W]	[Btu/Wh]	[kcal/Wh]	[W]	[A]	[kg/h]			
[°C]	-23,3	54,4	32,2	32,2	161,3	551	138,8	1,22	4,16	1,05	132,4	0,91	3,13	ASHRAE LBP			
[°F]	-10	130	90	90													
[°C]	-25	55	32	55	119,0	406	102,4	0,94	3,22	0,81	126,1	0,90	2,85	cecomaf LBP			
[°F]	-13	131	89,6	131													
[°C]	-35	40	20	40	78,2	267	67,3	0,90	3,09	0,78	86,5	0,81	1,72	EN12900 LBP			
[°F]	-31	104	68	104													
[°C]	-23,3	48,9	4,44	48,9	132,5	452	114,0	1,01	3,44	0,87	131,6	0,91	3,50	ARI540 LBP			
[°F]	-10	120	40	120													
[°C]	-23,3	40,6	32,2	32,2	180,0	615	154,9	1,41	4,81	1,21	127,8	0,90	3,50	AHAM LBP			
[°F]	-10	105	90	90													
[°C]	-35	45	32	45	73,2	250	63,0	0,84	2,86	0,72	87,4	0,82	1,58	opt			
[°F]	-31	113	89,6	113													

Performance tables

R134a, 220V/60Hz, RSIR, static, VDE, EAC

	pe	Cooling capacity				COP	EER	P1	I	m	
	[°C]	[°F]	[W]	[Btu/h]	[kcal/h]	[W/W]	[Btu/Wh]	[kcal/Wh]	[W]	[A]	[kg/h]
[°C / °F]	-35	-31	73,2	250	63,0	0,84	2,86	0,72	87,4	0,82	1,58
cond. pressure	-30	-22	105,6	361	90,9	0,99	3,38	0,85	106,7	0,86	2,28
pc= 45/113	-25	-13	142,3	486	122,5	1,14	3,91	0,98	124,4	0,90	3,08
return gas temp.	-23,3	-10	156,0	533	134,3	1,20	4,10	1,03	130,1	0,91	3,38
RGT= 32/90	-20	-4	184,8	631	159,1	1,31	4,49	1,13	140,7	0,93	4,02
liquid temp	-15	5	234,7	801	202,0	1,51	5,14	1,30	155,9	0,97	5,12
Tliq= 45/113	-10	14	293,3	1002	252,4	1,72	5,88	1,48	170,3	1,01	6,42
[°C / °F]	-35	-31	58,9	201	50,7	0,68	2,32	0,58	86,8	0,81	1,40
cond. pressure	-30	-22	87,2	298	75,0	0,81	2,78	0,70	107,0	0,85	2,08
pc= 55/131	-25	-13	119,0	406	102,4	0,94	3,22	0,81	126,1	0,90	2,85
return gas temp	-23,3	-10	130,9	447	112,7	0,99	3,38	0,85	132,4	0,91	3,13
RGT= 32/90	-20	-4	155,9	532	134,2	1,08	3,69	0,93	144,4	0,94	3,74
liquid temp	-15	5	199,3	681	171,5	1,23	4,20	1,06	162,1	0,99	4,80
Tliq= 55/131	-10	14	250,7	856	215,7	1,40	4,77	1,20	179,3	1,04	6,06



NL Compressors





Service/Repair – R600a, R290

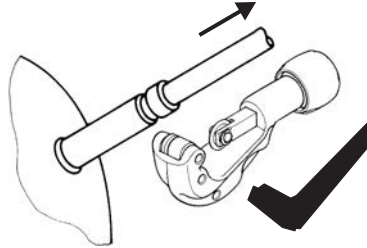

8545

Brazing on Suction Connectors (Direct Intake)

representative image



**! max. 150°C/302°F !
at socket**
brazing solder: phosphor (LP7) or silver

Refer to Product Bulletin:
**Brazing on Suction Connectors
(Compressors with Direct Suction Intake)**

Secop accepts no responsibility for possible errors in catalogs, brochures, and other printed material. Secop reserves the right to alter its products without notice. This also applies to products already on order provided that such alterations can be made without subsequential changes being necessary to specifications already agreed. All trademarks in this material are the property of the respective companies. Secop and the Secop logotype are trademarks of Secop GmbH. All rights reserved. www.secop.com