

## Single Pack NLE9KTK 220-240V 50/60Hz RSIR

Single pack code number: **195B4563**

Position	Title	Code	Amount
1	Compressor NLE9KTK	105H6071	1
2	PTC starting device (220V, 250hm, 4.8mm)	103N0018	1
3	Cord relief	103N1010	1
4	Protection screen for PTC	103N0476	1
5	Cover	103N2010	1
6	Bolt joint for one compressor   M6   ø16mm	118-1917	1

Secop GmbH • Lise-Meitner-Straße 29 • 24941 Flensburg, Germany • Tel: +49 461 4941 0 • [www.secop.com](http://www.secop.com)

Secop accepts no responsibility for possible errors in catalogs, brochures, and other printed material. Secop reserves the right to alter its products without notice. This also applies to products already on order provided that such alterations can be made without subsequent changes being necessary to specifications already agreed. All trademarks in this material are the property of the respective companies. Secop and the Secop logotype are trademarks of Secop GmbH. All rights reserved.

**Model**

Designation	<b>NLE9KTK</b>	<b>220-240V/50Hz 1~</b>	<b>220-240V/60Hz 1~</b>	Sales code:	<b>105H6071</b>
-------------	----------------	-------------------------	-------------------------	-------------	-----------------

**Compressor design**

Oil type	Mineral	Refrigerant(s)	<b>R600a</b>
Oil viscosity	15cST	Displacement	8,35cm <sup>3</sup> / 0,51cu.in
Oil quantity	300cm <sup>3</sup> / 10,1fl.oz	Compressors on pallet	80
Refr. charge - tech. limit	150g / 5,3oz		
Free gas volume comp.	2360cm <sup>3</sup> / 79,8fl.oz		
Weight	10kg / 22lbs		
Motor protection	1# internal		
Winding resistance main	14,9Ω (at 25°C)		
Winding resistance aux	17,9Ω (at 25°C)		
Max. winding temp.	125°C / 257°F		
Max. discharge temp.	130°C / 266°F		



**General - Configurations with NLE9KTK**

	<b>Conf. 1</b>	<b>Conf. 2</b>	<b>Conf. 3</b>
Motorconfiguration	RSIR	RSCR	RSCR
Power supply (nominal)	220-240V/50Hz	220-240V/50Hz	220-240V/60Hz
Number of phases	1	1	1
Voltage range	187-254V	187-254V	198-253V
Approvals	VDE	VDE	VDE
Starting torque	LST	LST	LST
Note	- / -		

**Applications with NLE9KTK**

	<b>Conf. 1</b>	<b>Conf. 2</b>	<b>Conf. 3</b>
Refrigerant	R600a	R600a	R600a
Application	LBP	LBP	LBP
System cooling	static	static	static
Hot gas defrost	- / -	- / -	- / -
Long interval pull down	- / -	- / -	- / -

**Electrical data - Configurations with NLE9KTK**

	<b>Conf. 1</b>	<b>Conf. 2</b>	<b>Conf. 3</b>
Starting device type	PTC	PTC	PTC
Run capacitor	- / -	4μF	4μF
Start capacitor	- / -	- / -	- / -
LRA (locked rotor amps / 4s)	5A	5A	5A
RLA (rated load amps / 1s)	0,9A	0,9A	0,9A
Cut in current	9,4A	9,4A	9,4A

**Model**

Designation **NLE9KTK** 220-240V/50Hz 1~ 220-240V/60Hz 1~ Sales code: **105H6071**

**Compressor dimensions**

<b>Housing</b>	A Height	197mm / 7,76in
	B Height	191mm / 7,52in
	C Length shell	205mm / 8,07in
	D Length w. cover	254mm / 10in
	E Width	166mm / 6,54in

<b>Connectors</b>		<b>Suction</b>	<b>Discharge</b>	<b>Process</b>
		<b>X</b>	<b>Y</b>	<b>Z</b>
Diameter	[mm]	øi 6,11-6,29	øi 5,12-5,22	øi 6,11-6,29
	(i:inside, o:outside) [in]	øi 0,24-0,25	øi 0,2-0,21	øi 0,24-0,25
Material		copper	copper	copper
Horizontal angle	±2°	0°	0°	0°
Vertical angle	±2°	15°	35°	155°
Position l/h/w	[mm]	126/76/78	133/103/54	-107/94/72
	[in]	4,9/3/3,1	5,2/4/2,1	-4,2/3,7/2,8
Straight tube l.	[mm]	12	12	12
	[in]	0,5	0,5	0,5

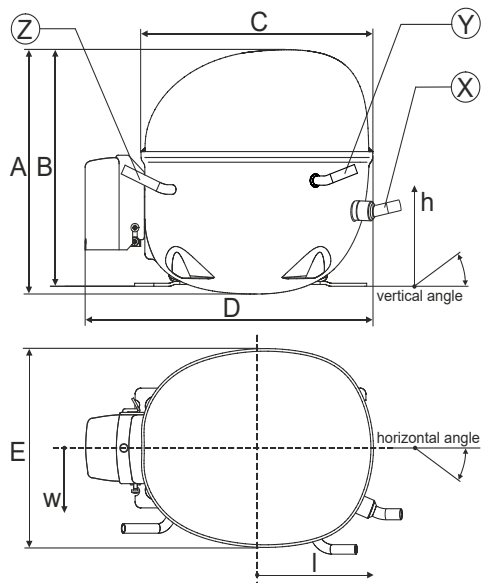

**Compressor fixation**

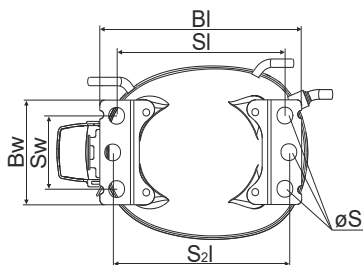

Baseplate	[mm]	[inch]
Bi	204	8.03
Bw	100	3.94

  

Small holes	[mm]	[inch]
Si	170	6.7
Sw	70	2.76
S2l	178	7
øS	ø 16	ø 0.63

**Bolt joint**

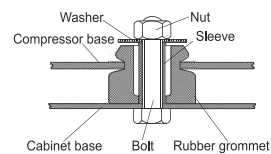

**Snap-on**

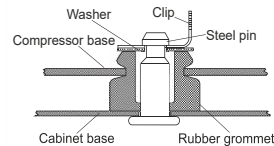

<b>Mounting accessories</b>	one comp.	multi pack
Bolt joint   M6   ø16mm	118-1917	118-1918
Bolt joint   ø1/4"   ø16mm	118-1946	
Snap-on   ø7,3   ø16mm	118-1947	118-1919

**Model**

Designation	<b>NLE9KTK</b>	<b>220-240V/50Hz</b>	<b>Conf. 1</b>	Sales code:	<b>105H6071</b>
-------------	----------------	----------------------	----------------	-------------	-----------------

**Configuration**

Motorconfiguration	RSIR
Power supply (nominal)	220-240V/50Hz 1~
Refrigerant	R600a
Application	LBP
Voltage range	187-254V
Starting torque	LST
Approvals	VDE

**Electrical accessories / wiring diagram**

RSIR

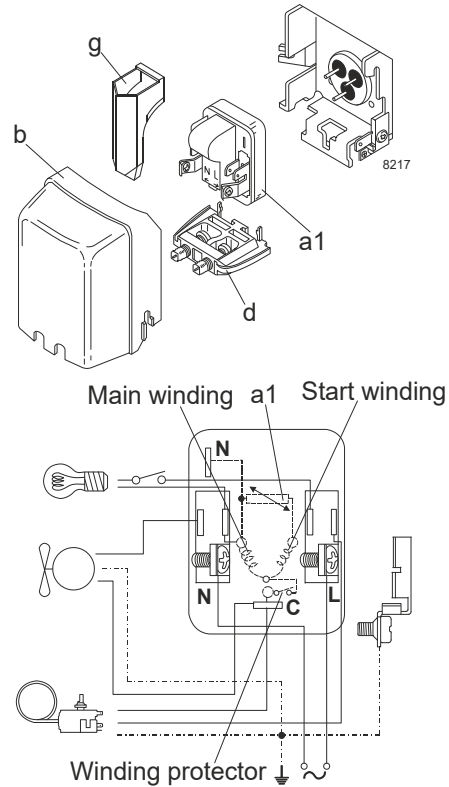

**Ambient temperatures / system cooling**

Ambient temperature min.:	10°C / 50°F
Ambient temperature max.:	43°C / 110°F

System cooling (n/a: outside limits)			
T ambient	LBP	MBP	HBP
32°C / 90°F	static	n/a	n/a
38°C / 100°F	static	n/a	n/a
43°C / 110°F	static	n/a	n/a

**Operation pressure range**

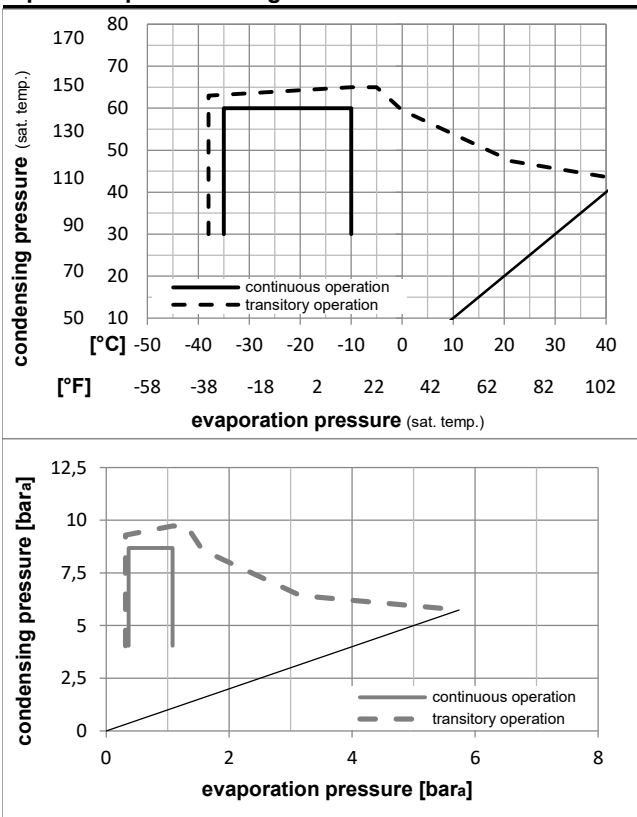

Components

a1	PTC starter (220V, 250hm, 4.8mm)	103N0018
b	plastic cover	103N2010
d	cord relief	103N1010
g	protection screen for PTC	103N0476

Alternative components

a1	PTC starter (220V, 250hm, 6.3mm)	103N0011
b	plastic cover	103N2011
d	cord relief	103N1010
g	protection screen for PTC	103N0476

**Model**

Designation **NLE9KTK 220-240V/50Hz** Conf. 1 Sales code: **105H6071**

**Optimization + standard conditions**

R600a, 220V/50Hz, RSIR, static, VDE

Evaporating pressure (saturation temperature)																	
Condensing pressure (saturation temperature)										Power consumption							
Return gas temp.					Cooling capacity					COP		EER		P1	Current consumption		Ref. mass flow m
Liquid temp.					[W]					[W/W]		[Btu/Wh]		[kcal/Wh]	[W]	[A]	
pe	pc	RGT	Tliq		[W]	[Btu/h]	[kcal/h]	[W/W]	[Btu/Wh]	[kcal/Wh]	[W]	[A]	[kg/h]				
[°C]	-23,3	54,4	32,2	32,2	131,0	447	112,7	1,32	4,52	1,14	98,9	0,76	1,41	ASHRAE LBP			
[°F]	-10	130	90	90													
[°C]	-25	55	32	55	98,0	335	84,4	1,03	3,52	0,89	95,0	0,75	1,28	cecomaf LBP			
[°F]	-13	131	89,6	131													
[°C]	-35	40	20	40	63,5	217	54,7	0,90	3,07	0,77	70,8	0,66	0,77	EN12900 LBP			
[°F]	-31	104	68	104													
[°C]	-23,3	48,9	4,44	48,9	106,5	364	91,6	1,08	3,70	0,93	98,4	0,76	1,56	ARI540 LBP			
[°F]	-10	120	40	120													
[°C]	-23,3	40,6	32,2	32,2	140,8	481	121,1	1,46	4,98	1,25	96,6	0,75	1,51	AHAM LBP			
[°F]	-10	105	90	90													
[°C]	-35	45	32	45	61,8	211	53,2	0,86	2,92	0,74	72,3	0,67	0,73	opt			
[°F]	-31	113	89,6	113													

**Performance tables**

R600a, 220V/50Hz, RSIR, static, VDE

	pe		Cooling capacity			COP		EER		P1	I	m
	[°C]	[°F]	[W]	[Btu/h]	[kcal/h]	[W/W]	[Btu/Wh]	[kcal/Wh]	[W]	[A]	[kg/h]	
[°C / °F]	-35	-31	61,8	211	53,2	0,86	2,92	0,74	72,3	0,67	0,73	
cond. pressure	-30	-22	84,4	288	72,6	1,03	3,51	0,88	82,2	0,70	1,00	
pc= 45/113	-25	-13	113,0	386	97,3	1,21	4,12	1,04	93,6	0,74	1,35	
return gas temp.	-23,3	-10	124,3	425	107,0	1,27	4,34	1,09	97,7	0,75	1,48	
RGT= 32/90	-20	-4	148,8	508	128,0	1,40	4,79	1,21	106,0	0,78	1,77	
liquid temp	-15	5	192,8	658	165,9	1,62	5,55	1,40	118,7	0,81	2,30	
Tliq= 45/113	-10	14	246,2	841	211,9	1,88	6,41	1,62	131,2	0,85	2,95	
[°C / °F]	-35	-31	54,3	186	46,8	0,72	2,45	0,62	75,7	0,67	0,71	
cond. pressure	-30	-22	73,8	252	63,5	0,88	2,99	0,75	84,3	0,71	0,96	
pc= 55/131	-25	-13	98,0	335	84,4	1,03	3,52	0,89	95,0	0,75	1,28	
return gas temp	-23,3	-10	107,6	368	92,6	1,09	3,71	0,93	99,1	0,76	1,40	
RGT= 32/90	-20	-4	128,3	438	110,4	1,20	4,08	1,03	107,3	0,78	1,68	
liquid temp	-15	5	165,7	566	142,6	1,37	4,69	1,18	120,6	0,82	2,17	
Tliq= 55/131	-10	14	211,2	721	181,7	1,57	5,37	1,35	134,3	0,86	2,77	

### Model

Designation	<b>NLE9KTK</b>	<b>220-240V/50Hz</b>	<b>Conf. 2</b>	Sales code:	<b>105H6071</b>
-------------	----------------	----------------------	----------------	-------------	-----------------

### Configuration

Motorconfiguration	RSCR
Power supply (nominal)	220-240V/50Hz 1~
Refrigerant	R600a
Application	LBP
Voltage range	187-254V
Starting torque	LST
Approvals	VDE

### Electrical accessories / wiring diagram

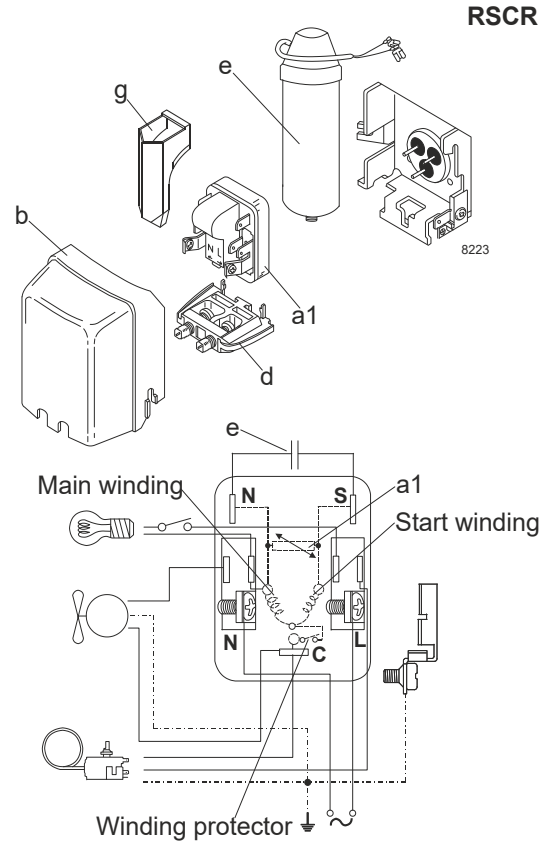

### Ambient temperatures / system cooling

Ambient temperature min.:	10°C / 50°F
Ambient temperature max.:	43°C / 110°F

System cooling (n/a: outside limits)			
T ambient	LBP	MBP	HBP
32°C / 90°F	static	n/a	n/a
38°C / 100°F	static	n/a	n/a
43°C / 110°F	static	n/a	n/a

### Operation pressure range

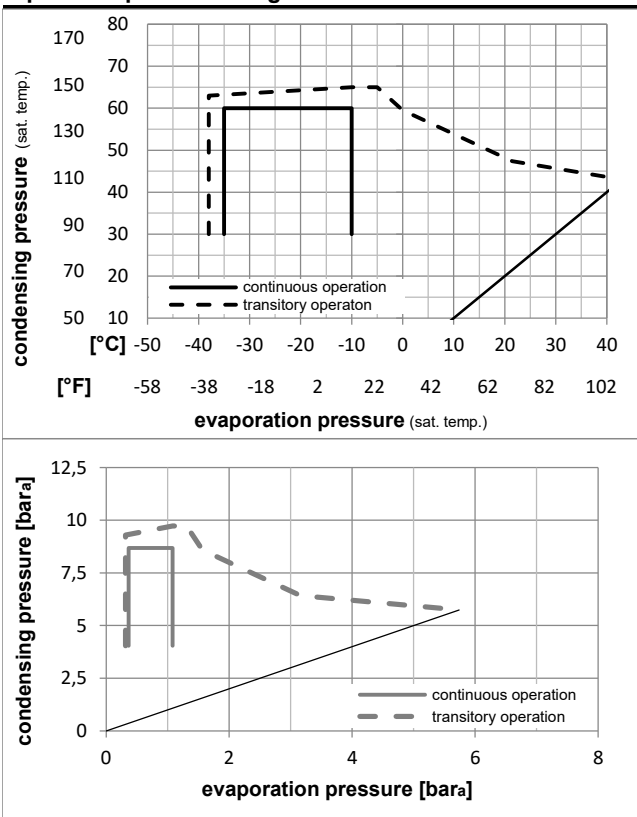

### Components

a1	PTC starter (220V, 250hm, 4.8mm)	103N0021
e	run capacitor (4μF, 4.8mm)	117-7119
b	plastic cover	103N2010
d	cord relief	103N1010
g	protection screen for PTC	103N0476
	bracket for run capacitor	117-0300

### Alternative components

a1	PTC starter (220V, 250hm, 6.3mm)	103N0016
e	run capacitor (4μF, 6.3mm)	117-7117
b	plastic cover	103N2011
	screw M4x8mm	117-0301

**Model**

Designation **NLE9KTK 220-240V/50Hz** Conf. 2 Sales code: **105H6071**

**Optimization + standard conditions**

R600a, 220V/50Hz, RSCR, static, VDE

		Evaporating pressure (saturation temperature)			Condensing pressure (saturation temperature)			Return gas temp.		Liquid temp.		Cooling capacity			COP	EER	Power consumption			Ref. mass flow m	
		pe	pc	RGT	Tliq	[W]	[Btu/h]	[kcal/h]	[W/W]	[Btu/Wh]	[kcal/Wh]	P1	I	Current consumption							
[°C]	[°F]											[W]	[A]	[kg/h]							
-23	-10	54,4	130	32,2	90	132,3	452	113,8	1,38	4,71	1,19	96,0	0,74	1,42						ASHRAE LBP	
-25	-13	55	131	32	131	99,0	338	85,2	1,07	3,67	0,92	92,2	0,73	1,29						cecomaf LBP	
-35	-31	40	104	20	104	64,2	219	55,2	0,93	3,19	0,80	68,6	0,64	0,78						EN12900 LBP	
-23	-10	48,9	120	4,44	120	107,5	367	92,6	1,13	3,85	0,97	95,4	0,73	1,57						ARI540 LBP	
-23	-10	40,6	105	32,2	90	142,2	486	122,4	1,52	5,18	1,31	93,7	0,73	1,53						AHAM LBP	
-35	-31	45	113	32	113	62,5	213	53,8	0,89	3,04	0,77	70,2	0,65	0,74						opt	

**Performance tables**

R600a, 220V/50Hz, RSCR, static, VDE

	pe		Cooling capacity			COP	EER	P1	I	m	
	[°C]	[°F]	[W]	[Btu/h]	[kcal/h]	[W/W]	[Btu/Wh]	[kcal/Wh]	[W]	[A]	[kg/h]
[°C / °F]	-35	-31	62,5	213	53,8	0,89	3,04	0,77	70,2	0,65	0,74
cond. pressure	-30	-22	85,2	291	73,4	1,07	3,65	0,92	79,7	0,68	1,01
pc= 45/113	-25	-13	114,1	390	98,2	1,26	4,29	1,08	90,8	0,72	1,36
return gas temp.	-23	-10	125,6	429	108,1	1,32	4,52	1,14	94,8	0,73	1,50
RGT= 32/90	-20	-4	150,3	513	129,3	1,46	4,99	1,26	102,8	0,75	1,79
liquid temp	-15	5	194,7	665	167,6	1,69	5,78	1,46	115,2	0,79	2,33
Tliq= 45/113	-10	14	248,7	849	214,0	1,95	6,67	1,68	127,3	0,82	2,98
[°C / °F]	-35	-31	54,9	187	47,2	0,75	2,55	0,64	73,5	0,65	0,71
cond. pressure	-30	-22	74,5	254	64,1	0,91	3,11	0,78	81,7	0,69	0,97
pc= 55/131	-25	-13	99,0	338	85,2	1,07	3,67	0,92	92,2	0,73	1,29
return gas temp	-23	-10	108,7	371	93,5	1,13	3,86	0,97	96,1	0,74	1,42
RGT= 32/90	-20	-4	129,6	443	111,5	1,24	4,25	1,07	104,1	0,76	1,69
liquid temp	-15	5	167,3	571	144,0	1,43	4,88	1,23	117,0	0,80	2,19
Tliq= 55/131	-10	14	213,3	728	183,6	1,64	5,59	1,41	130,3	0,83	2,80

**Model**

Designation	<b>NLE9KTK</b>	<b>220-240V/60Hz</b>	<b>Conf. 3</b>	Sales code:	<b>105H6071</b>
-------------	----------------	----------------------	----------------	-------------	-----------------

**Configuration**

Motorconfiguration	RSCR
Power supply (nominal)	220-240V/60Hz 1~
Refrigerant	R600a
Application	LBP
Voltage range	198-253V
Starting torque	LST
Approvals	VDE

**Electrical accessories / wiring diagram**

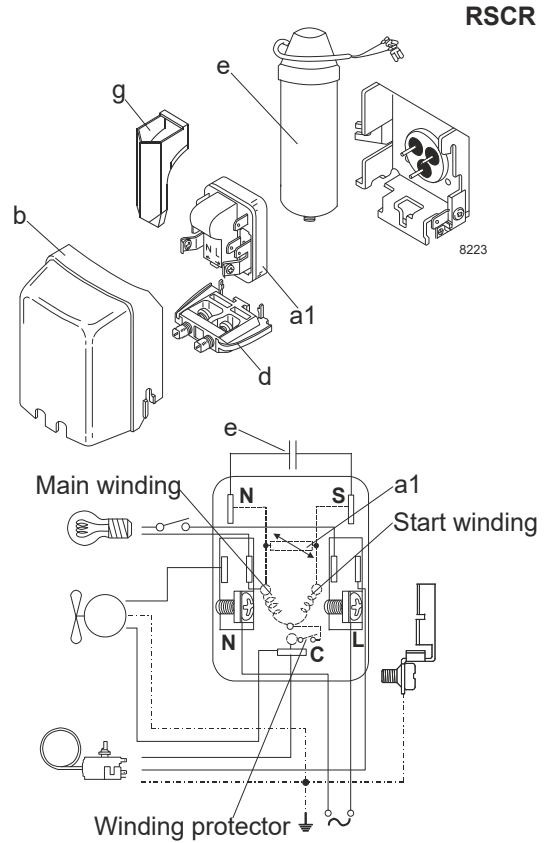

**Ambient temperatures / system cooling**

Ambient temperature min.:	10°C / 50°F
Ambient temperature max.:	38°C / 101°F

System cooling (n/a: outside limits)			
T ambient	LBP	MBP	HBP
32°C / 90°F	static	n/a	n/a
38°C / 100°F	static	n/a	n/a
43°C / 110°F	fan 1,5m/s	n/a	n/a

**Operation pressure range**

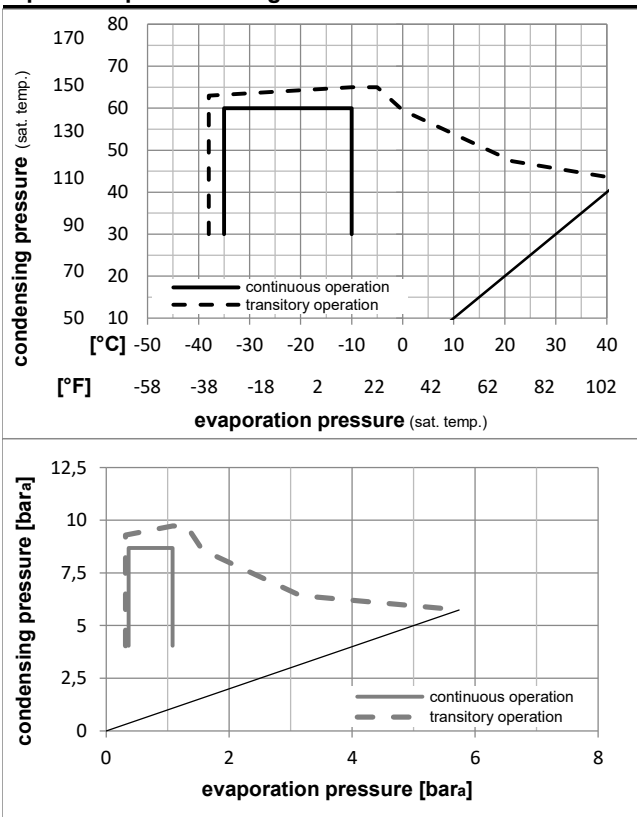

**Components**

a1	PTC starter (220V, 250ohm, 4.8mm)	103N0021
e	run capacitor (4µF, 4.8mm)	117-7119
b	plastic cover	103N2010
d	cord relief	103N1010
g	protection screen for PTC	103N0476
	bracket for run capacitor	117-0300

**Alternative components**

a1	PTC starter (220V, 250ohm, 6.3mm)	103N0016
e	run capacitor (4µF, 6.3mm)	117-7117
b	plastic cover	103N2011
	screw M4x8mm	117-0301



**Model**

Designation **NLE9KTK 220-240V/60Hz** Conf. 3 Sales code: **105H6071**

**Optimization + standard conditions**

R600a, 220V/60Hz, RSCR, static, VDE

		Evaporating pressure (saturation temperature)				Condensing pressure (saturation temperature)					Power consumption								
						Return gas temp.			Liquid temp.		Cooling capacity			COP	EER	P1	I	Ref. mass flow	
		pe	pc	RGT	Tliq	[W]	[Btu/h]	[kcal/h]	[W/W]	[Btu/Wh]	[kcal/Wh]	[W]	[A]	[kg/h]					
[°C]	-23,3	54,4	32,2	32,2	151,9	519	130,7	1,29	4,41	1,11	117,7	0,90	1,63	ASHRAE LBP					
[°F]	-10	130	90	90															
[°C]	-25	55	32	55	113,7	388	97,9	1,01	3,44	0,87	113,1	0,89	1,48	cecomaf LBP					
[°F]	-13	131	89,6	131															
[°C]	-35	40	20	40	73,7	252	63,4	0,88	2,99	0,75	84,2	0,79	0,90	EN12900 LBP					
[°F]	-31	104	68	104															
[°C]	-23,3	48,9	4,44	48,9	123,5	422	106,3	1,06	3,60	0,91	117,0	0,90	1,80	ARI540 LBP					
[°F]	-10	120	40	120															
[°C]	-23,3	40,6	32,2	32,2	163,3	558	140,5	1,42	4,85	1,22	114,9	0,89	1,75	AHAM LBP					
[°F]	-10	105	90	90															
[°C]	-35	45	32	45	71,7	245	61,7	0,83	2,85	0,72	86,1	0,79	0,85	opt					
[°F]	-31	113	89,6	113															

**Performance tables**

R600a, 220V/60Hz, RSCR, static, VDE

	pe	Cooling capacity			COP			EER			P1	I	m
	[°C]	[°F]	[W]	[Btu/h]	[kcal/h]	[W/W]	[Btu/Wh]	[kcal/Wh]	[W]	[A]	[kg/h]		
[°C / °F]	-35	-31	71,7	245	61,7	0,83	2,85	0,72	86,1	0,79	0,85		
cond. pressure	-30	-22	97,9	334	84,3	1,00	3,42	0,86	97,8	0,84	1,16		
pc= 45/113	-25	-13	131,1	448	112,8	1,18	4,02	1,01	111,4	0,88	1,56		
return gas temp.	-23,3	-10	144,2	492	124,1	1,24	4,23	1,07	116,3	0,89	1,72		
RGT= 32/90	-20	-4	172,6	589	148,5	1,37	4,67	1,18	126,1	0,92	2,06		
liquid temp	-15	5	223,7	764	192,5	1,58	5,41	1,36	141,3	0,97	2,67		
Tliq= 45/113	-10	14	285,6	975	245,8	1,83	6,25	1,57	156,1	1,01	3,42		
[°C / °F]	-35	-31	63,0	215	54,2	0,70	2,39	0,60	90,1	0,80	0,82		
cond. pressure	-30	-22	85,6	292	73,6	0,85	2,91	0,73	100,3	0,85	1,11		
pc= 55/131	-25	-13	113,7	388	97,9	1,01	3,44	0,87	113,1	0,89	1,48		
return gas temp	-23,3	-10	124,8	426	107,4	1,06	3,62	0,91	117,9	0,90	1,63		
RGT= 32/90	-20	-4	148,8	508	128,1	1,17	3,98	1,00	127,7	0,93	1,94		
liquid temp	-15	5	192,2	656	165,4	1,34	4,57	1,15	143,6	0,98	2,52		
Tliq= 55/131	-10	14	245,0	837	210,8	1,53	5,23	1,32	159,8	1,02	3,22		



8238-20

# NL Compressors

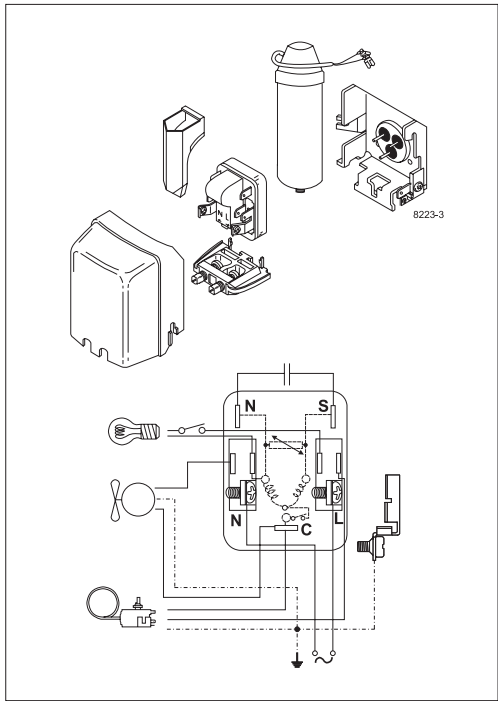
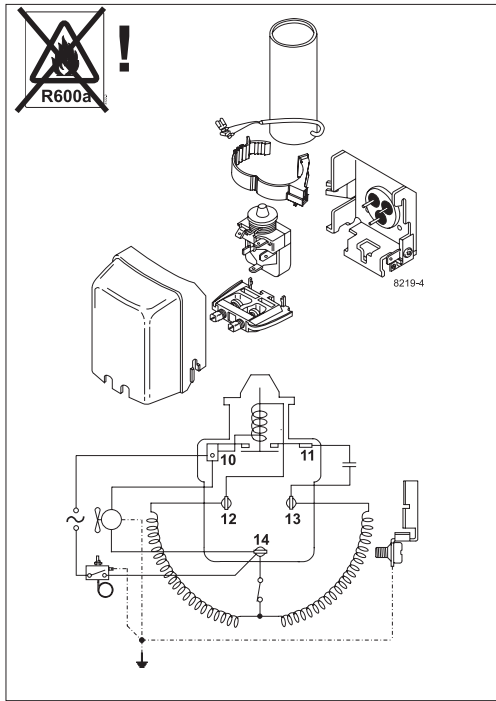



## Service/Repair – R600a, R290



8545

## Brazing on Suction Connectors (Direct Intake)

representative image



**! max. 150°C/302°F !  
at socket**  
brazing solder: phosphor (LP7) or silver

Refer to Product Bulletin:  
**Brazing on Suction Connectors  
(Compressors with Direct Suction Intake)**

Secop accepts no responsibility for possible errors in catalogs, brochures, and other printed material. Secop reserves the right to alter its products without notice. This also applies to products already on order provided that such alterations can be made without subsequential changes being necessary to specifications already agreed. All trademarks in this material are the property of the respective companies. Secop and the Secop logotype are trademarks of Secop GmbH. All rights reserved. [www.secop.com](http://www.secop.com)