

Single Pack HXK70AT 200-240V 50Hz RSIR

Single pack code number: **195B4616**

Position	Title	Code	Amount
1	Compressor HXK70AT	16425000	1
2	Clip	10633900	4
3	Steel pin	10634100	4
4	Washer	10634300	4
5	Screw for cable clamp	10636000	1
6	Screw for cable clamp	10636200	1
7	Cover	10636401	1
8	Earth screw	10641201	1
9	Rubber grommet 16mm	11322600	4
10	Cable clamp	11341000	1
11	Terminal board 6.3mm	15279300	1

Secop GmbH • Lise-Meitner-Straße 29 • 24941 Flensburg, Germany • Tel: +49 461 4941 0 • www.secop.com

Secop accepts no responsibility for possible errors in catalogs, brochures, and other printed material. Secop reserves the right to alter its products without notice. This also applies to products already on order provided that such alterations can be made without subsequent changes being necessary to specifications already agreed. All trademarks in this material are the property of the respective companies. Secop and the Secop logotype are trademarks of Secop GmbH. All rights reserved.

Model

Designation	HXK70AT	220-240V/50Hz 1~	Sales code:	16425000
-------------	----------------	-------------------------	-------------	-----------------

Compressor design

Oil type	Mineral	Refrigerant(s)	R600a
Oil viscosity	5cST	Displacement	6,64cm ³ / 0,41cu.in
Oil quantity	162cm ³ / 5,5fl.oz	Compressors on pallet	100
Refr. charge - tech. limit	150g / 5,3oz		
Free gas volume comp.	1620cm ³ / 54,8fl.oz		
Weight	8,2kg / 18,1lbs		
Motor protection	external		
Winding resistance main	24,3Ω (at 25°C)		
Winding resistance aux	13,8Ω (at 25°C)		
Max. winding temp.	130°C / 266°F		
Max. discharge temp.	130°C / 266°F		



General - Configurations with HXK70AT

	Conf. 1	Conf. 2	Conf. 3	Conf. 4
Motorconfiguration	RSIR	RSCR	RSIR	RSCR
Power supply (nominal)	200-240V/50Hz	200-240V/50Hz	220-240V/50Hz	220-240V/50Hz
Number of phases	1	1	1	1
Voltage range	170-264V	170-264V	170-264V	170-264V
Approvals	VDE	VDE	VDE	VDE
Starting torque	LST	LST	LST	LST
Note	Various options of connectors are possible - please contact SECOP-Sales.			

Applications with HXK70AT

	Conf. 1	Conf. 2	Conf. 3	Conf. 4
Refrigerant	R600a	R600a	R600a	R600a
Application	LBP	LBP	LBP	LBP
System cooling	static	static	static	static
Hot gas defrost	-/-	-/-	-/-	-/-
Long interval pull down	-/-	-/-	-/-	-/-

Electrical data - Configurations with HXK70AT

	Conf. 1	Conf. 2	Conf. 3	Conf. 4
Starting device type	PTC	PTC	PTC	PTC
Run capacitor	-/-	4μF	-/-	4μF
Start capacitor	-/-	-/-	-/-	-/-
LRA (locked rotor amps / 4s/ U(N))				
RLA (rated load amps / 1s/ U(N))	-/-A	-/-A	-/-A	-/-A
Cut in current (U(N))				

Model

Designation

HXK70AT

220-240V/50Hz 1~

Sales code:

16425000

Compressor dimensions

Housing	A Height	174mm / 6,85in
	B Height	167mm / 6,57in
	C Length shell	194mm / 7,64in
	D Length w. cover	238mm / 9,37in
	E Width	151mm / 5,94in

Connectors		Suction	Discharge	Process
		X	Y	Z
Diameter	[mm]	øi 6,1-6,2	øi 5,1-5,2	øo 5,92-6,08
	(i:inside, o:outside) [in]	øi 0,24-0,24	øi 0,2-0,2	øo 0,23-0,24
Material		copper	copper	copper
Horizontal angle	±2°	45°	13°	0°
Vertical angle	±2°	30°	40°	145°
Position l/h/w	[mm]	120/72/62	112/106/62	-140/136/70
	[in]	4,7/2,8/2,4	4,4/4,2/2,4	-5,5/5,4/2,8
Straight tube l.	[mm]	14	14	75
	[in]	0,5	0,5	3

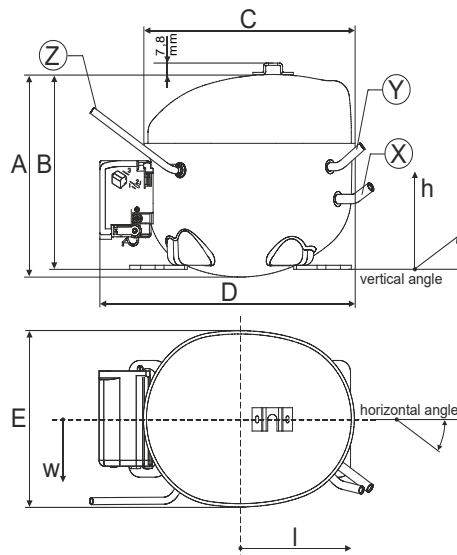

Compressor fixation

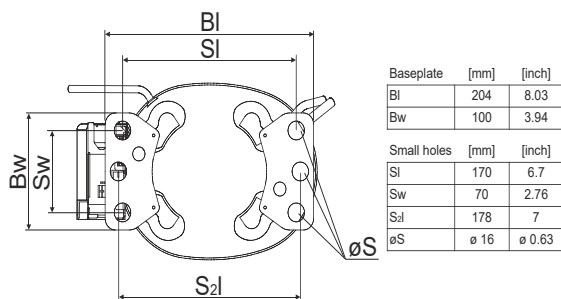

Bolt joint

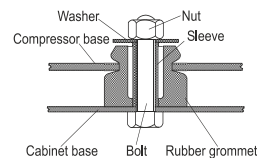

Snap-on

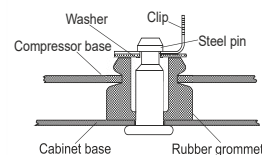

Mounting accessories

Accessories	order code
'4ZN' with rubber grommet	772N
'4ZN' with rubber grommet and sleeve for M6	768N
Bolt joint kit	4ZN + 118-1917 (18)
'4ZN' with Snap on kit	776N

Application notes

Provision for PE Grounding is located at the PE Stamp on the compressor

Housing with dip-tray fixture (omega bracket).

Various options of connectors are possible - please contact SECOP-Sales.

Model

Designation	HXK70AT	200-240V/50Hz	Conf. 1	Sales code:	16425000
-------------	----------------	----------------------	---------	-------------	-----------------

Configuration

Motorconfiguration	RSIR
Power supply (nominal)	200-240V/50Hz 1~
Refrigerant	R600a
Application	LBP
Voltage range	170-264V
Starting torque	LST
Approvals	VDE

Electrical accessories / wiring diagram

RSIR

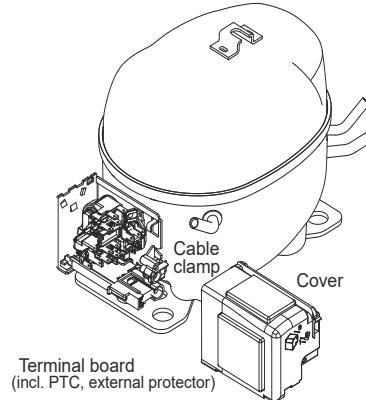

Ambient/ machine room temperatures minimum /maximum

Ambient temperature range:	10 - 43°C / 50 - 110°F
Machine room temperature range:	10 - 48°C / 50 - 119°F
Compressor cooling:	static



Operation pressure range

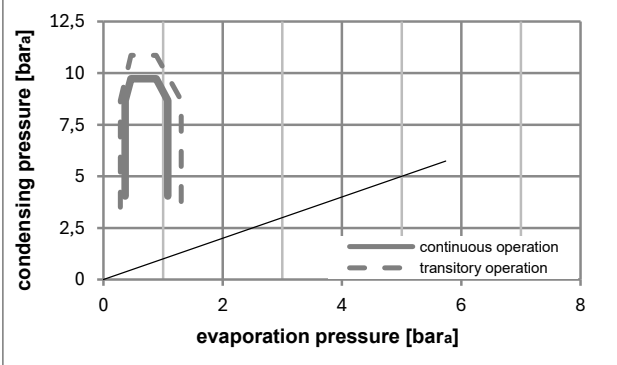
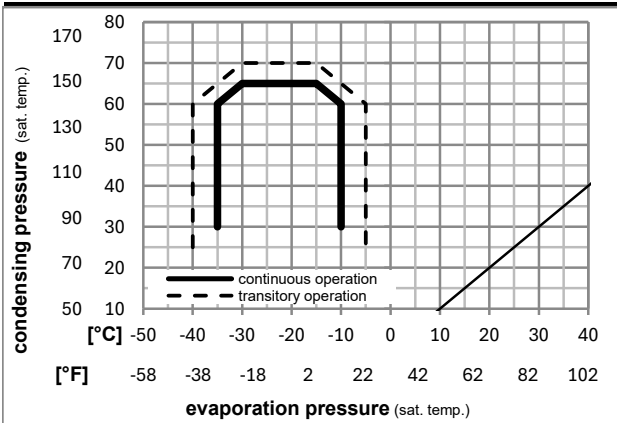

8858-6

Components

. terminal board (PTC, 6.3mm)	15279300
b cover terminal board	10636401
. cable clamp	11341000
. screw - uni6954	10636000
. screw - uni6954	10636200
. screw uni en iso 4757	10641201

Model

Designation	HXK70AT	200-240V/50Hz	Conf. 1	Sales code:	16425000
-------------	----------------	----------------------	---------	-------------	-----------------

Optimization + standard conditions

R600a, 200V/50Hz, RSIR, static, VDE

		Evaporating pressure (saturation temperature)				Condensing pressure (saturation temperature)			Return gas temp.		Liquid temp.		Cooling capacity			COP	EER	Power consumption			ASHRAE LBP
		pe	pc	RGT	Tliq	[W]	[Btu/h]	[kcal/h]	[W/W]	[Btu/Wh]	[kcal/Wh]	P1	I	Current consumption		ṁ	cecomaf LBP				
[°C]	[°F]	[°C]	[°F]	[°C]	[°C]	[W]	[Btu/h]	[kcal/h]	[W/W]	[Btu/Wh]	[kcal/Wh]	[W]	[A]	[A]	[kg/h]						
-23	54	32	32	118,3	404	101,8	1,64	5,59	1,41	72,2	0,36	1,27									
-10	130	90	90																		
-25	55	32	55	88,5	302	76,2	1,28	4,37	1,10	69,2	0,34	1,16									
-13	131	90	131																		
-35	40	20	40	66,4	227	57,1	1,29	4,39	1,11	51,6	0,26	0,81									
-31	104	68	104																		
-23	49	4,4	49	96,7	330	83,2	1,37	4,67	1,18	70,7	0,35	1,41									
-10	120	40	120																		
-23	41	32	32	125,9	430	108,3	1,87	6,39	1,61	67,2	0,34	1,35									
-10	105	90	90																		
-35	45	32	45	64,4	220	55,4	1,23	4,22	1,06	52,2	0,26	0,76									
-31	113	90	113																		

Performance tables

R600a, 200V/50Hz, RSIR, static, VDE

	pe		Cooling capacity			COP	EER	P1	I	m	
	[°C]	[°F]	[W]	[Btu/h]	[kcal/h]	[W/W]	[Btu/Wh]	[kcal/Wh]	[W]	[A]	[kg/h]
[°C / °F]	-35	-31	64,4	220	55,4	1,23	4,22	1,06	52,2	0,26	0,76
cond. pressure	-30	-22	80,9	276	69,6	1,36	4,66	1,17	59,3	0,30	0,96
pc= 45/113	-25	-13	103,3	353	88,9	1,55	5,29	1,33	66,7	0,33	1,23
return gas temp.	-23	-10	112,3	384	96,6	1,62	5,54	1,40	69,2	0,34	1,34
RGT= 32/90	-20	-4	131,8	450	113,4	1,77	6,06	1,53	74,3	0,37	1,57
liquid temp	-15	5	166,5	569	143,3	2,03	6,93	1,75	82,0	0,40	1,99
Tliq= 45/113	-10	14	207,6	709	178,6	2,31	7,89	1,99	89,8	0,43	2,48
[°C / °F]	-35	-31	48,1	164	41,4	0,95	3,24	0,82	50,7	0,26	0,63
cond. pressure	-30	-22	66,2	226	57,0	1,11	3,78	0,95	59,9	0,30	0,86
pc= 55/131	-25	-13	88,5	302	76,2	1,28	4,37	1,10	69,2	0,34	1,16
return gas temp	-23	-10	97,1	332	83,6	1,34	4,58	1,15	72,4	0,36	1,27
RGT= 32/90	-20	-4	115,1	393	99,0	1,46	5,00	1,26	78,6	0,38	1,50
liquid temp	-15	5	146,0	498	125,6	1,66	5,67	1,43	88,0	0,43	1,91
Tliq= 55/131	-10	14	181,3	619	156,0	1,86	6,37	1,60	97,2	0,47	2,38

Model

Designation	HXK70AT	200-240V/50Hz	Conf. 2	Sales code:	16425000
-------------	----------------	----------------------	----------------	-------------	-----------------

Configuration

Motorconfiguration	RSCR
Power supply (nominal)	200-240V/50Hz 1~
Refrigerant	R600a
Application	LBP
Voltage range	170-264V
Starting torque	LST
Approvals	VDE

Electrical accessories / wiring diagram

RSCR



Ambient/ machine room temperatures minimum /maximum

Ambient temperature range:	10 - 43°C / 50 - 110°F
Machine room temperature range:	10 - 48°C / 50 - 119°F
Compressor cooling:	static



Operation pressure range

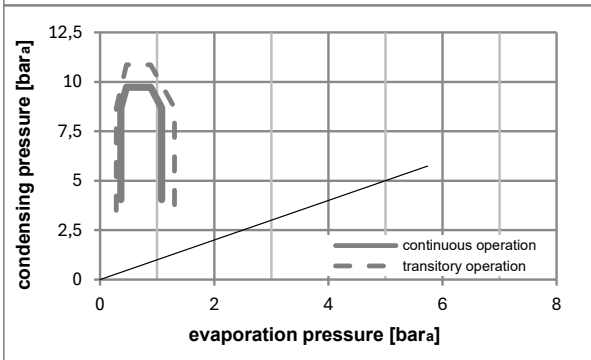
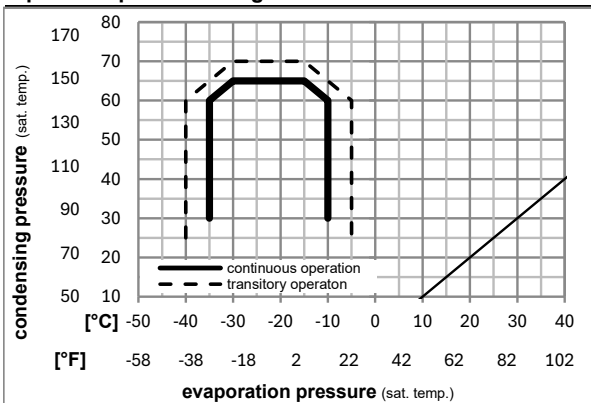

Components

. terminal board (PTC, 6.3mm)	15279300
. run capacitor (4µF, 6.3mm)	15186801
b cover terminal board	10636401
. cable clamp	11341000
. screw - uni6954	10636000
. screw - uni6954	10636200

Alternative components

. screw uni en iso 4757	10641201
-------------------------	----------

Model

Designation	HXK70AT	200-240V/50Hz	Conf. 2	Sales code:	16425000
-------------	----------------	----------------------	----------------	-------------	-----------------

Optimization + standard conditions

R600a, 200V/50Hz, RSCR, static, VDE

		Evaporating pressure (saturation temperature)				Cooling capacity			COP			EER			Power consumption			ASHRAE LBP
		Condensing pressure (saturation temperature)				Return gas temp.			EER			Current consumption			Ref. mass flow			
		Liquid temp.				Cooling capacity			EER			Current consumption						
		pe	pc	RGT	Tliq	[W]	[Btu/h]	[kcal/h]	[W/W]	[Btu/Wh]	[kcal/Wh]	P1	I	m	[W]	[A]	[kg/h]	
[°C]	-23	54	32	32	118,3	404	101,8	1,72	5,87	1,48	68,9	0,34	1,27					
[°F]	-10	130	90	90														
[°C]	-25	55	32	55	88,5	302	76,2	1,34	4,58	1,15	66,0	0,33	1,16					cecomaf LBP
[°F]	-13	131	90	131														
[°C]	-35	40	20	40	66,4	227	57,1	1,35	4,61	1,16	49,2	0,25	0,81					EN12900 LBP
[°F]	-31	104	68	104														
[°C]	-23	49	4,4	49	96,7	330	83,2	1,43	4,90	1,23	67,4	0,33	1,41					ARI540 LBP
[°F]	-10	120	40	120														
[°C]	-23	41	32	32	125,9	430	108,3	1,96	6,71	1,69	64,1	0,32	1,35					AHAM LBP
[°F]	-10	105	90	90														
[°C]	-35	45	32	45	64,4	220	55,4	1,29	4,42	1,11	49,7	0,25	0,76					opt
[°F]	-31	113	90	113														

Performance tables

R600a, 200V/50Hz, RSCR, static, VDE

	pe		Cooling capacity			COP			EER			P1			I			m			
	[°C]	[°F]	[W]	[Btu/h]	[kcal/h]	[W/W]	[Btu/Wh]	[kcal/Wh]	[W]	[A]	[kg/h]	[W]	[A]	[kg/h]	[W]	[A]	[kg/h]	[W]	[A]	[kg/h]	
[°C / °F]	-35	-31	64,4	220	55,4	1,29	4,42	1,11	49,7	0,25	0,76										
cond. pressure	-30	-22	80,9	276	69,6	1,43	4,89	1,23	56,5	0,28	0,96										
pc= 45/113	-25	-13	103,3	353	88,9	1,62	5,55	1,40	63,6	0,32	1,23										
return gas temp.	-23	-10	112,3	384	96,6	1,70	5,81	1,46	66,0	0,33	1,34										
RGT= 32/90	-20	-4	131,8	450	113,4	1,86	6,36	1,60	70,8	0,35	1,57										
liquid temp	-15	5	166,5	569	143,3	2,13	7,27	1,83	78,2	0,38	1,99										
Tliq= 45/113	-10	14	207,6	709	178,6	2,42	8,28	2,09	85,6	0,41	2,48										
[°C / °F]	-35	-31	48,1	164	41,4	0,99	3,39	0,86	48,4	0,24	0,63										
cond. pressure	-30	-22	66,2	226	57,0	1,16	3,96	1,00	57,1	0,29	0,86										
pc= 55/131	-25	-13	88,5	302	76,2	1,34	4,58	1,15	66,0	0,33	1,16										
return gas temp	-23	-10	97,1	332	83,6	1,41	4,80	1,21	69,0	0,34	1,27										
RGT= 32/90	-20	-4	115,1	393	99,0	1,54	5,24	1,32	75,0	0,37	1,50										
liquid temp	-15	5	146,0	498	125,6	1,74	5,94	1,50	83,9	0,41	1,91										
Tliq= 55/131	-10	14	181,3	619	156,0	1,96	6,68	1,68	92,7	0,45	2,38										

Model

Designation	HXK70AT	220-240V/50Hz	Conf. 3	Sales code:	16425000
-------------	----------------	----------------------	----------------	-------------	-----------------

Configuration

Motorconfiguration	RSIR
Power supply (nominal)	220-240V/50Hz 1~
Refrigerant	R600a
Application	LBP
Voltage range	170-264V
Starting torque	LST
Approvals	VDE

Electrical accessories / wiring diagram

RSIR

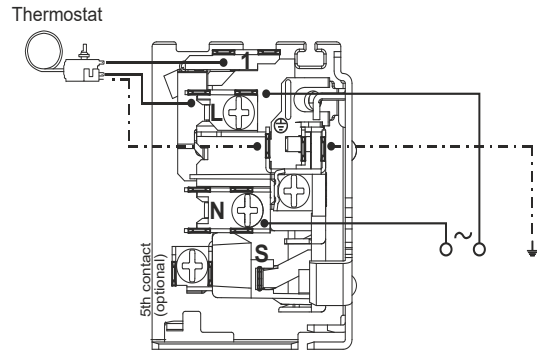
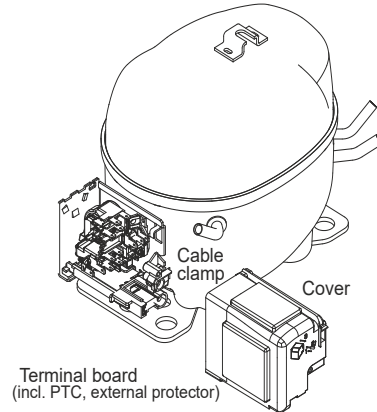

Ambient/ machine room temperatures minimum /maximum

Ambient temperature range:	10 - 43°C / 50 - 110°F
Machine room temperature range:	10 - 48°C / 50 - 119°F
Compressor cooling:	static

Operation pressure range

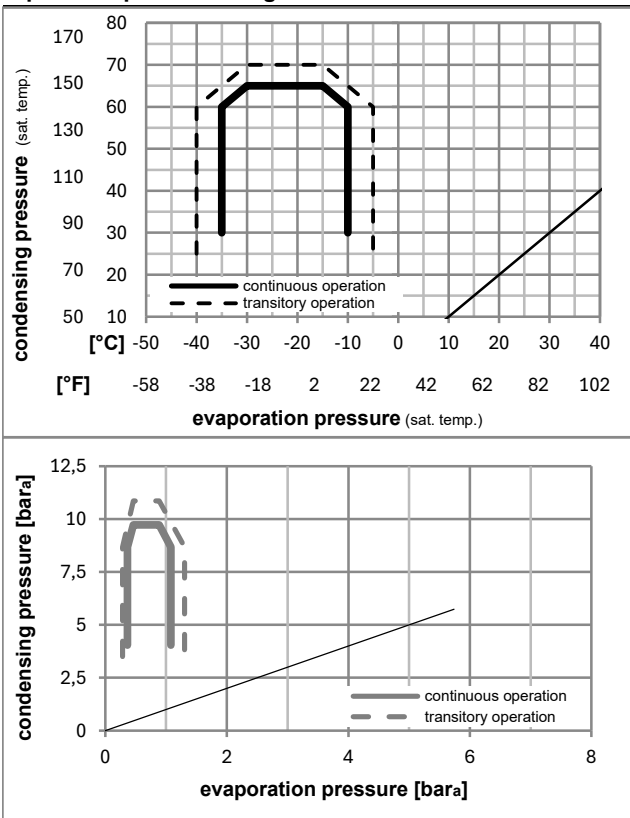

8858-6

Components

.	terminal board (PTC, 6.3mm)	15279300
b	cover terminal board	10636401
.	cable clamp	11341000
.	screw - uni6954	10636000
.	screw - uni6954	10636200
.	screw uni en iso 4757	10641201

Model

Designation **HXK70AT** **220-240V/50Hz** Conf. 3 Sales code: **16425000**

Optimization + standard conditions

R600a, 230V/50Hz, RSIR, static, VDE

	Evaporating pressure (saturation temperature)				Condensing pressure (saturation temperature)			Return gas temp.			Liquid temp.			Cooling capacity			COP	EER	Power consumption			ASHRAE LBP
	pe	pc	RGT	Tliq	[W]	[Btu/h]	[kcal/h]	[W/W]	[Btu/Wh]	[kcal/Wh]	P1	I	m	[W]	[A]	[kg/h]						
[°C]	-23	54	32	32	117,5	401	101,2	1,57	5,37	1,35	74,8	0,37	1,26									
[°F]	-10	130	90	90																		
	-25	55	32	55	87,9	300	75,7	1,23	4,19	1,06	71,6	0,36	1,15								cecomaf LBP	
	-35	40	20	40	65,9	225	56,8	1,23	4,22	1,06	53,4	0,27	0,80								EN12900 LBP	
	-31	104	68	104																		
	-23	49	4,4	49	96,0	328	82,7	1,31	4,48	1,13	73,1	0,36	1,40								ARI540 LBP	
	-10	120	40	120																		
	-23	41	32	32	125,0	427	107,6	1,80	6,14	1,55	69,6	0,35	1,34								AHAM LBP	
	-10	105	90	90																		
	-35	45	32	45	64,0	218	55,0	1,18	4,05	1,02	54,0	0,27	0,76								opt	
	-31	113	90	113																		

Performance tables

R600a, 230V/50Hz, RSIR, static, VDE

	pe		Cooling capacity			COP	EER		P1	I	m
	[°C]	[°F]	[W]	[Btu/h]	[kcal/h]	[W/W]	[Btu/Wh]	[kcal/Wh]	[W]	[A]	[kg/h]
[°C / °F]	-35	-31	64,0	218	55,0	1,18	4,05	1,02	54,0	0,27	0,76
cond. pressure	-30	-22	80,3	274	69,1	1,31	4,47	1,13	61,3	0,31	0,95
pc= 45/113	-25	-13	102,6	350	88,3	1,49	5,08	1,28	69,0	0,35	1,22
return gas temp.	-23	-10	111,5	381	96,0	1,56	5,32	1,34	71,7	0,36	1,33
RGT= 32/90	-20	-4	130,9	447	112,7	1,70	5,82	1,47	76,9	0,38	1,56
liquid temp	-15	5	165,4	565	142,4	1,95	6,65	1,68	84,9	0,42	1,98
Tliq= 45/113	-10	14	206,1	704	177,4	2,22	7,58	1,91	92,9	0,45	2,47
[°C / °F]	-35	-31	47,7	163	41,1	0,91	3,11	0,78	52,5	0,27	0,62
cond. pressure	-30	-22	65,8	225	56,6	1,06	3,63	0,91	62,0	0,31	0,86
pc= 55/131	-25	-13	87,9	300	75,7	1,23	4,19	1,06	71,6	0,36	1,15
return gas temp	-23	-10	96,4	329	83,0	1,29	4,39	1,11	74,9	0,37	1,26
RGT= 32/90	-20	-4	114,3	390	98,4	1,40	4,80	1,21	81,4	0,40	1,49
liquid temp	-15	5	145,0	495	124,8	1,59	5,44	1,37	91,1	0,44	1,90
Tliq= 55/131	-10	14	180,1	615	155,0	1,79	6,11	1,54	100,6	0,49	2,36

Model

Designation	HXK70AT	220-240V/50Hz	Conf. 4	Sales code:	16425000
-------------	----------------	----------------------	----------------	-------------	-----------------

Configuration

Motorconfiguration	RSCR
Power supply (nominal)	220-240V/50Hz 1~
Refrigerant	R600a
Application	LBP
Voltage range	170-264V
Starting torque	LST
Approvals	VDE

Electrical accessories / wiring diagram

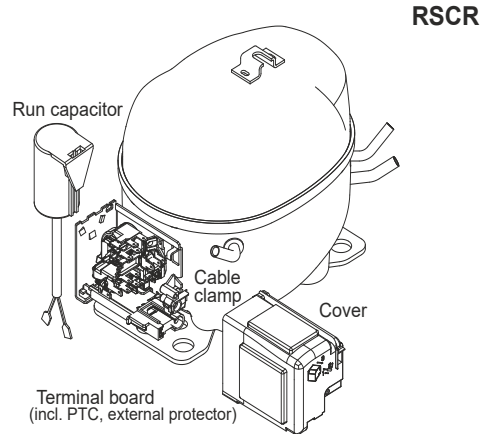

Ambient/ machine room temperatures minimum /maximum

Ambient temperature range:	10 - 43°C / 50 - 110°F
Machine room temperature range:	10 - 48°C / 50 - 119°F
Compressor cooling:	static

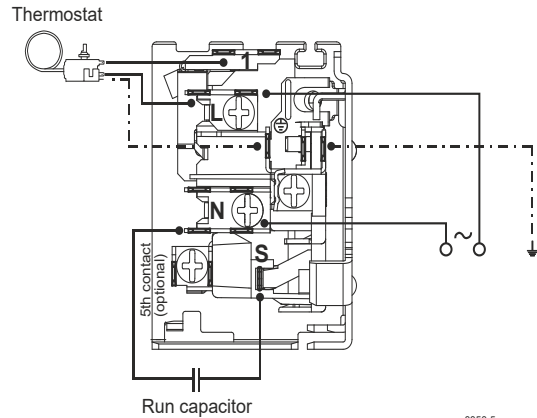

Operation pressure range

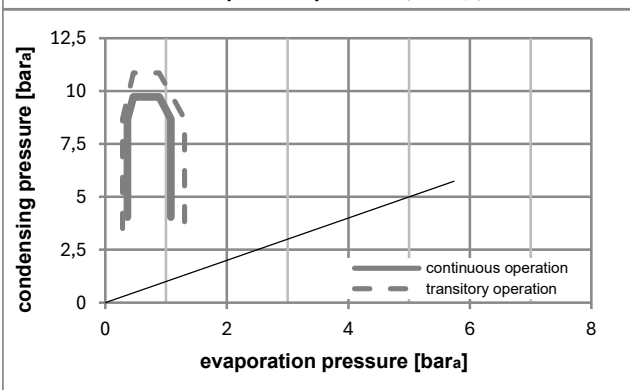
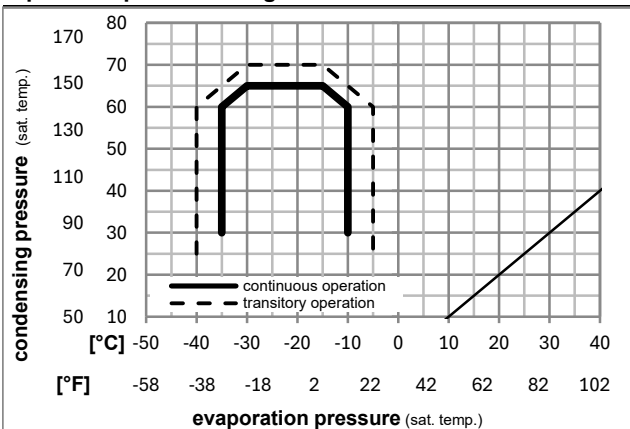

Components

. terminal board (PTC, 6.3mm)	15279300
. run capacitor (4μF, 6.3mm)	15186801
b cover terminal board	10636401
. cable clamp	11341000
. screw - uni6954	10636000
. screw - uni6954	10636200

Alternative components

. screw uni en iso 4757	10641201
-------------------------	----------

Model

Designation	HXK70AT	220-240V/50Hz	Conf. 4	Sales code:	16425000
-------------	----------------	----------------------	----------------	-------------	-----------------

Optimization + standard conditions

R600a, 230V/50Hz, RSCR, static, VDE

	Evaporating pressure (saturation temperature)				Condensing pressure (saturation temperature)			Return gas temp.	Liquid temp.	Cooling capacity			COP	EER	Power consumption			Ref. mass flow
	pe	pc	RGT	Tliq	[W]	[Btu/h]	[kcal/h]			P1	I	m						
[°C]	-23	54	32	32	117,5	401	101,2	1,65	5,63	1,42	71,3	0,35	1,26	ASHRAE LBP				
[°F]	-10	130	90	90														
[°C]	-25	55	32	55	87,9	300	75,7	1,29	4,40	1,11	68,3	0,34	1,15	cecomaf LBP				
[°F]	-13	131	90	131														
[°C]	-35	40	20	40	65,9	225	56,8	1,30	4,42	1,11	50,9	0,26	0,80	EN12900 LBP				
[°F]	-31	104	68	104														
[°C]	-23	49	4,4	49	96,0	328	82,7	1,38	4,70	1,19	69,7	0,35	1,40	ARI540 LBP				
[°F]	-10	120	40	120														
[°C]	-23	41	32	32	125,0	427	107,6	1,88	6,44	1,62	66,4	0,33	1,34	AHAM LBP				
[°F]	-10	105	90	90														
[°C]	-35	45	32	45	64,0	218	55,0	1,24	4,24	1,07	51,5	0,26	0,76	opt				
[°F]	-31	113	90	113														

Performance tables

R600a, 230V/50Hz, RSCR, static, VDE

	pe		Cooling capacity			COP	EER		P1	I	m
	[°C]	[°F]	[W]	[Btu/h]	[kcal/h]		[Btu/Wh]	[kcal/Wh]			
[°C / °F]	-35	-31	64,0	218	55,0	1,24	4,24	1,07	51,5	0,26	0,76
cond. pressure	-30	-22	80,3	274	69,1	1,37	4,69	1,18	58,5	0,30	0,95
pc= 45/113	-25	-13	102,6	350	88,3	1,56	5,33	1,34	65,8	0,33	1,22
return gas temp.	-23	-10	111,5	381	96,0	1,63	5,58	1,41	68,3	0,34	1,33
RGT= 32/90	-20	-4	130,9	447	112,7	1,79	6,10	1,54	73,3	0,36	1,56
liquid temp	-15	5	165,4	565	142,4	2,04	6,98	1,76	80,9	0,40	1,98
Tliq= 45/113	-10	14	206,1	704	177,4	2,33	7,95	2,00	88,6	0,43	2,47
[°C / °F]	-35	-31	47,7	163	41,1	0,95	3,26	0,82	50,0	0,25	0,62
cond. pressure	-30	-22	65,8	225	56,6	1,11	3,80	0,96	59,1	0,30	0,86
pc= 55/131	-25	-13	87,9	300	75,7	1,29	4,40	1,11	68,3	0,34	1,15
return gas temp	-23	-10	96,4	329	83,0	1,35	4,61	1,16	71,5	0,35	1,26
RGT= 32/90	-20	-4	114,3	390	98,4	1,47	5,03	1,27	77,6	0,38	1,49
liquid temp	-15	5	145,0	495	124,8	1,67	5,70	1,44	86,8	0,42	1,90
Tliq= 55/131	-10	14	180,1	615	155,0	1,88	6,41	1,62	95,9	0,46	2,36



K-Series Compressors

GTK, HKK, HMK, HTK, HXK, HZK



Service/Repair – R600a



K-Series Compressors

GTK, HKK, HMK, HTK, HXK, HZK

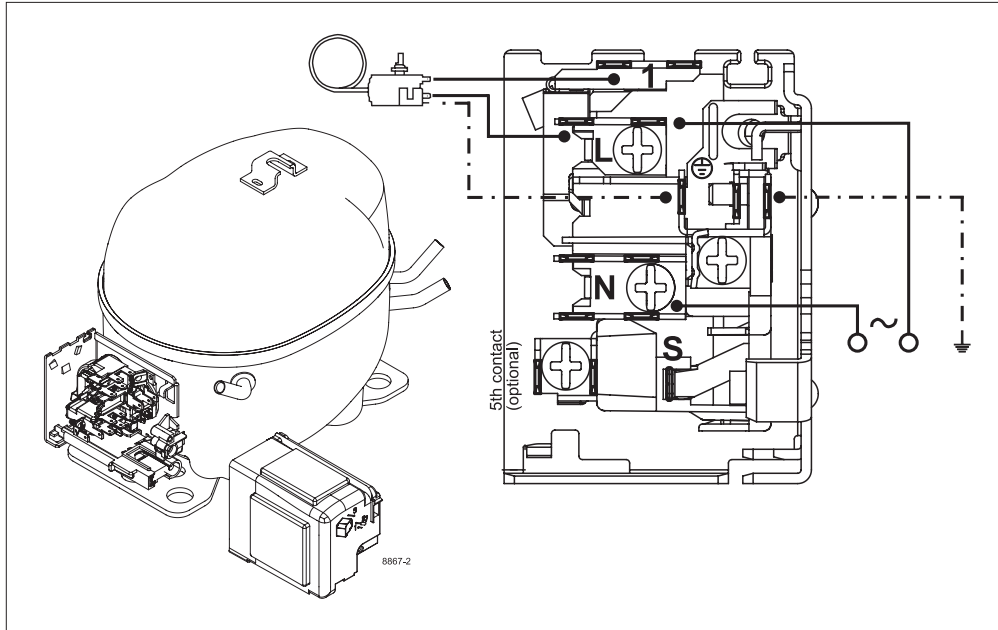

Service/Repair – R600a

Secop accepts no responsibility for possible errors in catalogs, brochures, and other printed material. Secop reserves the right to alter its products without notice. This also applies to products already on order provided that such alterations can be made without subsequential changes being necessary to specifications already agreed. All trademarks in this material are the property of the respective companies. Secop and the Secop logotype are trademarks of Secop GmbH. All rights reserved. www.secop.com