

Single Pack GS21MLX 187-254V 60Hz CSCR

Single pack code number: **195B4636**

Position	Title	Code	Amount
1	Compressor GS21MLX	107B0509	1
2	GS starting device (600mm)	117-7073	1
3	Bolt joint for one compressor M8 ø19mm	107B9150	1

Secop GmbH • Lise-Meitner-Straße 29 • 24941 Flensburg, Germany • Tel: +49 461 4941 0 • www.secop.com

Secop accepts no responsibility for possible errors in catalogs, brochures, and other printed material. Secop reserves the right to alter its products without notice. This also applies to products already on order provided that such alterations can be made without subsequent changes being necessary to specifications already agreed. All trademarks in this material are the property of the respective companies. Secop and the Secop logotype are trademarks of Secop GmbH. All rights reserved.

Model

Designation	GS21MLX	187-254V/60Hz 1~	Sales code:	107B0509
-------------	----------------	------------------	-------------	-----------------

Compressor design

Oil type	Polyolester	Refrigerant(s)	R404A, R507, R452A
Oil viscosity	32,5cST	Displacement	21,2cm ³ / 1,29cu.in
Oil quantity	902cm ³ / 30,5fl.oz	Compressors on pallet	48
Refr. charge - tech. limit	2000g / 70,5oz		
Free gas volume comp.	3540cm ³ / 119,7fl.oz		
Weight	22,2kg / 48,9lbs		
Motor protection	1# internal		
Winding resistance main	1,5Ω (at 25°C)		
Winding resistance aux	5,8Ω (at 25°C)		
Max. winding temp.			
Max. discharge temp.	130°C / 266°F		



General - Configurations with GS21MLX

	Conf. 1	Conf. 2
Motorconfiguration	CSCR	CSCR
Power supply (nominal)	208-230V/60Hz	208-230V/60Hz
Number of phases	1	1
Voltage range	187-254V	187-254V
Approvals	UL	UL
Starting torque	HST	HST
Note	Cover, clamp, gasket: pre-assembled to compressor.	

Applications with GS21MLX

	Conf. 1	Conf. 2
Refrigerant	R404A	R452A
Application	MBP	MBP
System cooling	fan 3m/s	fan 3m/s
Hot gas defrost	OK	OK
Long interval pull down	OK	OK

Electrical data - Configurations with GS21MLX

	Conf. 1	Conf. 2
Starting device type	relay	relay
Run capacitor	20μF	20μF
Start capacitor	100μF	100μF
LRA (locked rotor amps / 4s)	46A	46A
RLA (rated load amps / 1s)	11A	11A
Cut in current	46A	46A

Model

Designation

GS21MLX

187-254V/60Hz 1~

Sales code:

107B0509

Compressor dimensions

Housing	A Height	279mm / 10,98in
	B Height	267mm / 10,51in
	C Length shell	224mm / 8,82in
	D Length w. cover	232mm / 9,13in
	E Width	173mm / 6,81in

Connectors	Suction	Discharge	Process
	X	Y	Z
Diameter [mm]	øi 12,75-13,05	øi 9,63-9,73	øi 6,4-6,6
(i:inside, o:outside) [in]	øi 0,5-0,51	øi 0,38-0,38	øi 0,25-0,26
Material	copper	copper	copper
Horizontal angle ±2°	0°	0°	0°
Vertical angle ±2°	90°	71°	90°
Position l/h/w [mm]	-95/234/-84	-105/84/-84	95/234/84
[in]	-3,7/9,2/-3,3	-4,1/3,3/-3,3	3,7/9,2/3,3
Straight tube l.	[mm]	18	23
	[in]	0,7	0,9

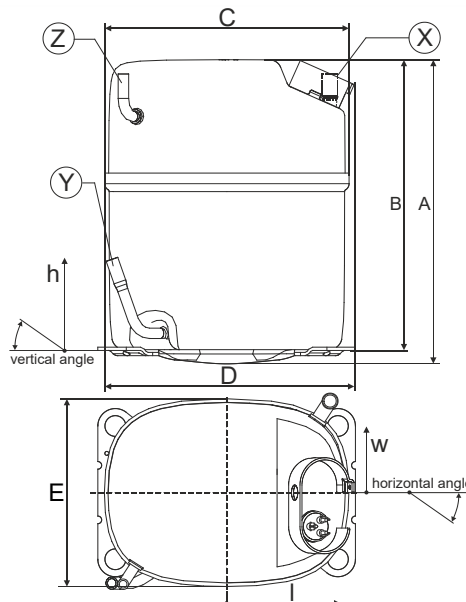

Compressor fixation

Bolt joint

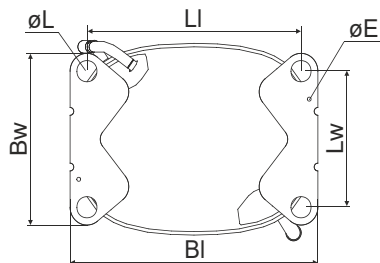

Baseplate	[mm]	[inch]
BI	235	9.25
Bw	154	6.06
øE	ø 3.6	ø 0.14

Large holes	[mm]	[inch]
LI	203	7.99
Lw	122	4.80
øL	ø 19	ø 0.75

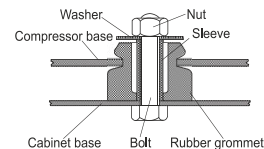

Mounting accessories

Bolt joint | M8 | ø19mm

one comp.

107B9150

Model

Designation	GS21MLX	208-230V/60Hz	Conf. 1	Sales code:	107B0509
-------------	----------------	----------------------	----------------	-------------	-----------------

Configuration

Motorconfiguration	CSCR
Power supply (nominal)	208-230V/60Hz 1~
Refrigerant	R404A
Application	MBP
Voltage range	187-254V
Starting torque	HST
Approvals	UL

Electrical accessories / wiring diagram

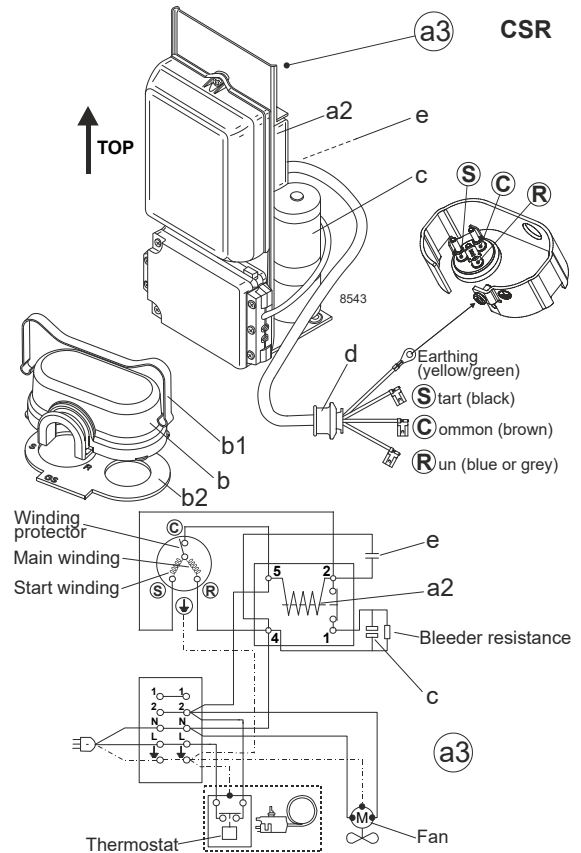

Ambient/ machine room temperatures minimum /maximum

Ambient temperature range:	10 - 43°C / 50 - 110°F
Machine room temperature range:	10 - 48°C / 50 - 119°F
Compressor cooling:	fan 3m/s

Operation Limits

Operation pressure range

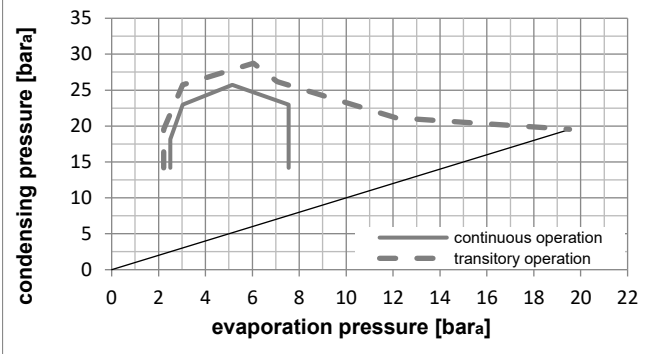
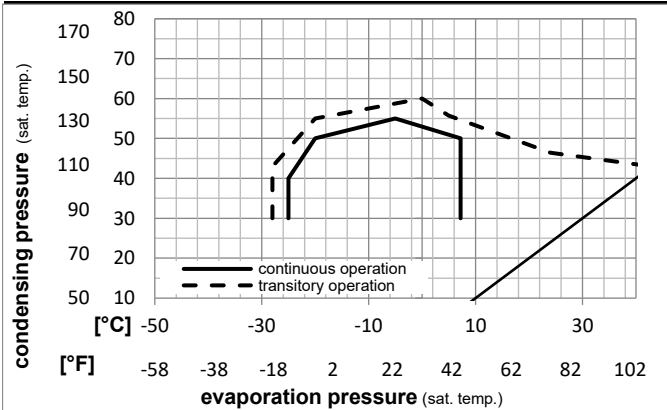

Components (cover, clamp, gasket: pre assembled)

a3	GS starter kit (600mm)	117-7073
b	cover	107B9101
b2	gasket	107B9100
b1	clamp	107B9104

Model

Designation **GS21MLX 208-230V/60Hz** Conf. 1 Sales code: **107B0509**

Optimization + standard conditions

R404A, 230V/60Hz, CSCR, fan 3m/s, UL

Evaporating pressure (saturation temperature)					Condensing pressure (saturation temperature)						Power consumption			
					Return gas temp.			Liquid temp.			Current consumption			Ref. mass flow
					Cooling capacity			COP	EER		P1	I	m	
	pe	pc	RGT	Tliq	[W]	[Btu/h]	[kcal/h]	[W/W]	[Btu/Wh]	[kcal/Wh]	[W]	[A]	[kg/h]	
[°C]	-7	54	35	46	2515,2	8590	2164,6	1,86	6,34	1,60	1354,2	6,22	69,21	ASHRAE MBP
[°F]	20,012	130	95	115										
[°C]	-10	55	32	55	1872,8	6396	1611,7	1,47	5,01	1,26	1276,9	5,90	59,95	cecomaf MBP
[°F]	14	131	90	131										
[°C]	-10	45	20	45	2268,1	7746	1951,9	1,93	6,57	1,66	1178,2	5,48	68,32	EN12900 MBP
[°F]	14	113	68	113										
[°C]	-7	49	18	49	2334,9	7974	2009,5	1,81	6,19	1,56	1287,7	5,95	76,30	ARI540 MBP
[°F]	20,012	120	65	120										
[°C]	-10	45	32	45	2407,1	8221	2071,6	2,04	6,98	1,76	1178,2	5,48	66,29	opt
[°F]	14	113	90	113										
[°C]	-25	45	32	45	1180,9	4033	1016,3	1,36	4,64	1,17	868,7	4,15	31,85	opt
[°F]	-13	113	90	113										

Performance tables

R404A, 230V/60Hz, CSCR, fan 3m/s, UL

	pe		Cooling capacity			COP	EER		P1	I	m
	[°C]	[°F]	[W]	[Btu/h]	[kcal/h]	[W/W]	[Btu/Wh]	[kcal/Wh]	[W]	[A]	[kg/h]
[°C / °F]	-25	-13	1180,9	4033	1016,3	1,36	4,64	1,17	868,7	4,15	31,85
cond. pressure	-23	-10	1293,2	4417	1113,0	1,43	4,88	1,23	904,6	4,31	34,95
pc= 45/113	-15	5	1938,5	6620	1668,3	1,80	6,14	1,55	1077,8	5,05	52,95
return gas temp.	-9	15	2463,5	8413	2120,1	2,07	7,07	1,78	1189,2	5,52	67,91
RGT= 32/90	-4	25	3081,8	10525	2652,2	2,37	8,10	2,04	1298,8	5,98	85,87
liquid temp	0	32	3578,0	12219	3079,2	2,60	8,89	2,24	1375,0	6,29	100,59
Tliq= 45/113	7,2	45	4657,4	15906	4008,2	3,07	10,48	2,64	1517,4	6,84	133,56
[°C / °F]	-25	-13	899,6	3072	774,2	1,03	3,53	0,89	870,9	4,27	28,12
cond. pressure	-23	-10	991,3	3385	853,1	1,08	3,69	0,93	918,6	4,46	31,05
pc= 55/131	-15	5	1505,4	5141	1295,6	1,31	4,48	1,13	1147,1	5,37	47,74
return gas temp	-9	15	1916,9	6547	1649,7	1,48	5,07	1,28	1291,0	5,96	61,44
RGT= 32/90	-4	25	2400,8	8199	2066,2	1,68	5,73	1,45	1429,8	6,52	77,92
liquid temp	0	32	2790,6	9530	2401,6	1,83	6,25	1,58	1524,6	6,90	91,51
Tliq= 55/131	7,2	45	3645,3	12449	3137,2	2,15	7,34	1,85	1696,9	7,59	122,35

Model

Designation	GS21MLX	208-230V/60Hz	Conf. 2	Sales code:	107B0509
-------------	----------------	----------------------	---------	-------------	-----------------

Configuration

Motorconfiguration	CSCR
Power supply (nominal)	208-230V/60Hz 1~
Refrigerant	R452A
Application	MBP
Voltage range	187-254V
Starting torque	HST
Approvals	UL

Electrical accessories / wiring diagram

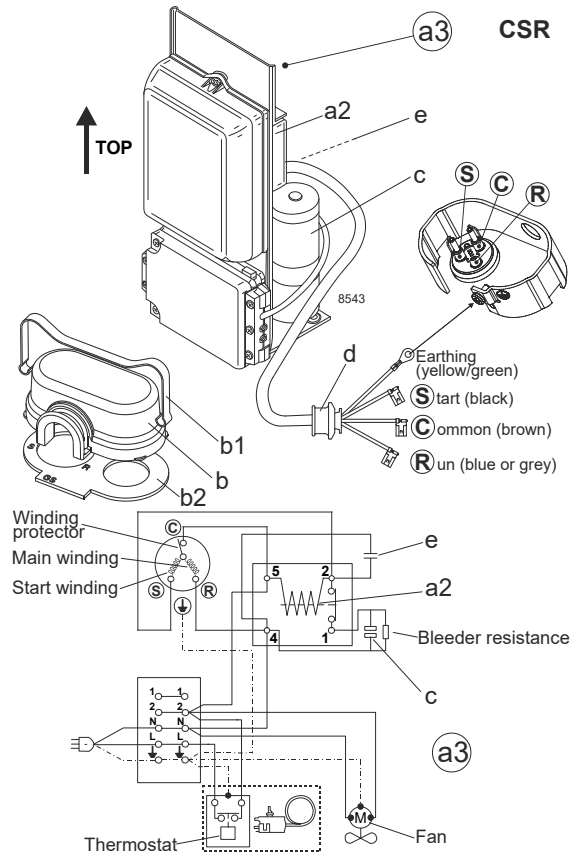

Ambient/ machine room temperatures minimum /maximum

Ambient temperature range:	10 - 43°C / 50 - 110°F
Machine room temperature range:	10 - 48°C / 50 - 119°F
Compressor cooling:	fan 3m/s

Operation Limits

Operation pressure range

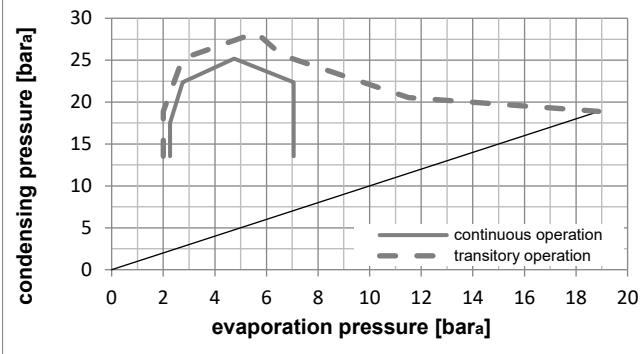
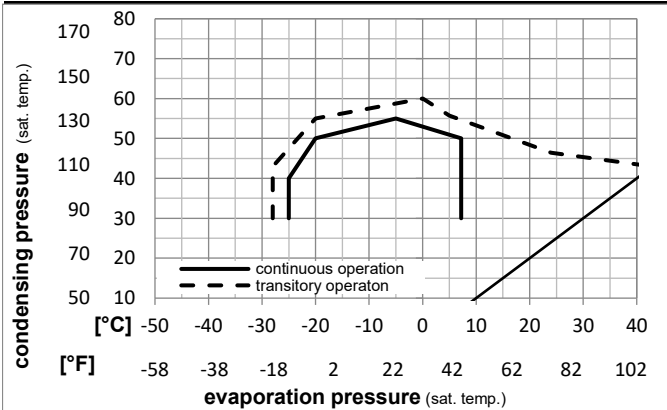

Components (cover, clamp, gasket: pre assembled)

a3	GS starter kit (600mm)	117-7073
b	cover	107B9101
b2	gasket	107B9100
b1	clamp	107B9104

Model

Designation **GS21MLX 208-230V/60Hz** Conf. 2 Sales code: **107B0509**

Optimization + standard conditions

R452A, 230V/60Hz, CSCR, fan 3m/s, UL

Evaporating pressure (saturation temperature)					Condensing pressure (saturation temperature)						Power consumption			
					Return gas temp.			Liquid temp.			Current consumption		Ref. mass flow	
pe	pc	RGT	Tliq		Cooling capacity			COP	EER		P1	I	m	
[°C]	[°F]	[°C]	[°F]	[°C]	[W]	[Btu/h]	[kcal/h]	[W/W]	[Btu/Wh]	[kcal/Wh]	[W]	[A]	[kg/h]	
-7	54	35	46	20,012	2381,7	8134	2049,7	1,86	6,36	1,60	1279,7	5,91	67,00	ASHRAE MBP
14	131	95	115											
-10	55	32	55	20,012	1776,3	6066	1528,7	1,48	5,05	1,27	1201,3	5,59	57,73	cecomaf MBP
14	131	90	131											
-10	45	20	45	20,012	2142,9	7318	1844,2	1,93	6,59	1,66	1110,8	5,22	65,84	EN12900 MBP
14	113	68	113											
-7	49	18	49	20,012	2221,5	7587	1911,9	1,82	6,23	1,57	1218,2	5,66	73,70	ARI540 MBP
14	120	65	120											
-10	45	32	45	20,012	2270,8	7755	1954,2	2,04	6,98	1,76	1110,8	5,22	63,98	opt
14	113	90	113											
-25	45	32	45	20,012	1087,8	3715	936,1	1,35	4,62	1,16	803,8	3,96	30,09	opt
-13	113	90	113											

Performance tables

R452A, 230V/60Hz, CSCR, fan 3m/s, UL

	pe		Cooling capacity			COP	EER	P1	I	m	
	[°C]	[°F]	[W]	[Btu/h]	[kcal/h]	[W/W]	[Btu/Wh]	[kcal/Wh]	[W]	[A]	[kg/h]
[°C / °F]	-25	-13	1087,8	3715	936,1	1,35	4,62	1,16	803,8	3,96	30,09
cond. pressure	-23	-10	1195,1	4082	1028,6	1,42	4,86	1,23	839,0	4,11	33,11
pc= 45/113	-15	5	1816,2	6203	1563,1	1,80	6,14	1,55	1010,3	4,81	50,81
return gas temp.	-9	15	2325,7	7943	2001,5	2,07	7,08	1,78	1121,9	5,27	65,58
RGT= 32/90	-4	25	2928,8	10002	2520,6	2,38	8,11	2,04	1233,1	5,72	83,40
liquid temp	0	32	3414,8	11662	2938,8	2,60	8,89	2,24	1311,5	6,04	98,01
Tliq= 45/113	7,2	45	4476,3	15287	3852,3	3,07	10,47	2,64	1460,4	6,65	130,78
[°C / °F]	-25	-13	828,9	2831	713,3	1,03	3,53	0,89	802,1	3,96	26,38
cond. pressure	-23	-10	917,2	3132	789,4	1,08	3,69	0,93	848,5	4,15	29,24
pc= 55/131	-15	5	1416,3	4837	1218,9	1,32	4,51	1,14	1072,2	5,06	45,65
return gas temp	-9	15	1819,7	6215	1566,0	1,50	5,11	1,29	1215,5	5,65	59,20
RGT= 32/90	-4	25	2297,0	7845	1976,8	1,69	5,79	1,46	1355,8	6,23	75,57
liquid temp	0	32	2683,2	9164	2309,2	1,85	6,31	1,59	1453,1	6,62	89,09
Tliq= 55/131	7,2	45	3533,4	12067	3040,9	2,16	7,39	1,86	1633,8	7,37	119,76

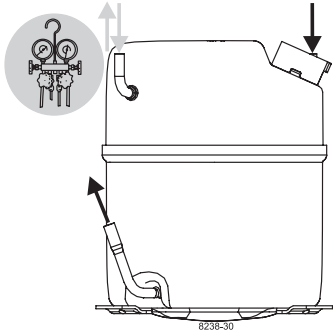

GS Compressors

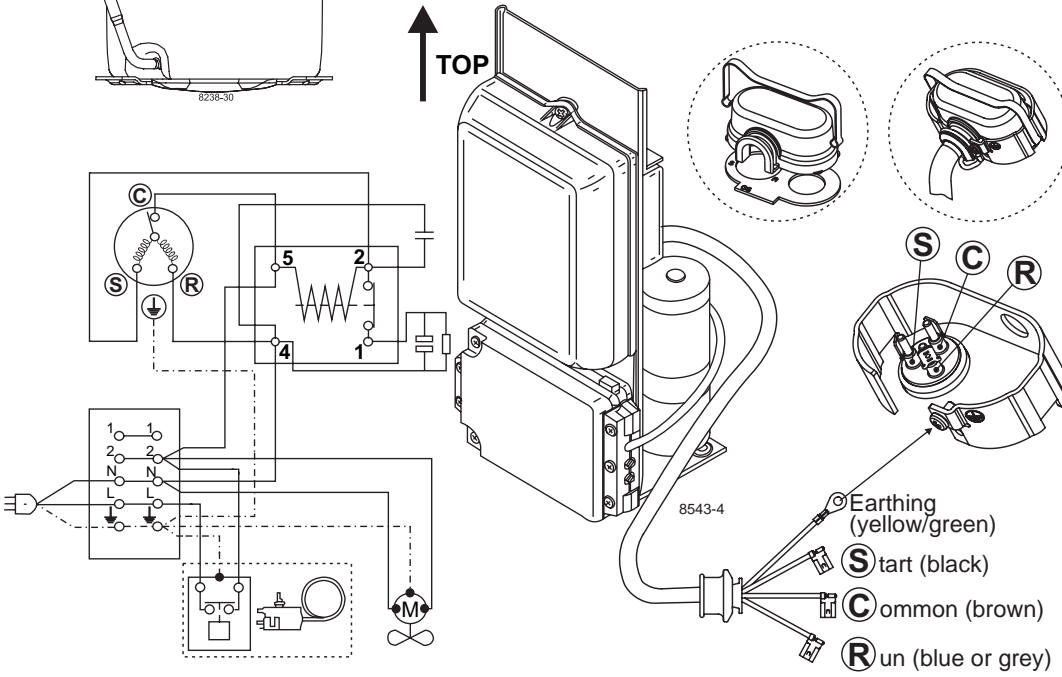

	S	C	R
ENGLISH	Black	Brown	Blue or grey
DEUTSCH	Schwarz	Braun	Blau od. grau
FRANÇAIS	Noir	Marron	Bleu ou gris
ESPAÑOL	Negro	Marrón	Azul o gris
ITALIANO	Nero	Marrone	Blu o grigio
NEDERLANDS	Zwart	Bruin	Blauw of grijs
DANSK	Sort	Brun	Blå eller grå
SVENSKA	Svart	Brun	Blå eller grå
SUOMEKSI	Musta	Ruskea	Sininen tai harmaa
РУССКИЙ	Чёрный	Коричневый	Синий или серый
中文	黑色	棕色	蓝色或灰色

Secop accepts no responsibility for possible errors in catalogs, brochures, and other printed material. Secop reserves the right to alter its products without notice. This also applies to products already on order provided that such alterations can be made without consequential changes being necessary to specifications already agreed. All trademarks in this material are the property of the respective companies. Secop and the Secop logotype are trademarks of Secop GmbH. All rights reserved. www.secop.com