

## Single Pack NLV12.6CN 100-240V 50/60Hz PM

Single pack code number: **195B4653**

Position	Title	Code	Amount
1	Compressor NLV12.6CN	105H6365	1
2	Cover	103N2008	1
3	Electronic unit NLV	105N4961	1
4	Bolt joint for one compressor   M6   ø16mm	118-1917	1

**Secop GmbH** • Lise-Meitner-Straße 29 • 24941 Flensburg, Germany • Tel: +49 461 4941 0 • [www.secop.com](http://www.secop.com)

Secop accepts no responsibility for possible errors in catalogs, brochures, and other printed material. Secop reserves the right to alter its products without notice. This also applies to products already on order provided that such alterations can be made without subsequent changes being necessary to specifications already agreed. All trademarks in this material are the property of the respective companies. Secop and the Secop logotype are trademarks of Secop GmbH. All rights reserved.

## Model

Designation	<b>NLV12.6CN</b>	Sales code:	<b>105H6365</b>
-------------	------------------	-------------	-----------------

## Compressor design

Oil type	Polyolester	Refrigerant(s)	<b>R290</b>
Oil viscosity	32cST	Displacement	12,55cm <sup>3</sup> / 0,77cu.in
Oil quantity	298cm <sup>3</sup> / 10,1fl.oz	Compressors on pallet	80
Refr. charge - tech. limit	300g / 10,6oz		
Free gas volume comp.	2360cm <sup>3</sup> / 79,8fl.oz		
Weight	10,8kg / 23,8lbs		
Motor protection	2# internal		
Winding resist. ph. to ph.	5,3Ω (at 25°C)		
Max. winding temp.	125°C / 257°F		
Max. discharge temp.	130°C / 266°F		



## General - Configurations and Applications with NLV12.6CN and Controller

	<b>Conf. 1</b>	<b>Conf. 2</b>	<b>Conf. 3</b>	<b>Conf. 4</b>
Sales code single pack:	105N4910	105N4960	105N4962	105N4866
Sales code industry pack:	105N4911	105N4961	105N4963	105N4867
Power supply (nominal)	220-240V 50/60Hz	100-240V 50/60Hz	100-240V 50/60Hz	100-240V 50/60Hz
Approvals	VDE,CCC	VDE,UL,CCC,CB	VDE,UL,CCC,CB	CCC,VDE,UL,CB
Refrigerant	R290	R290	R290	R290
Number of phases	1~ AC	1~ AC	1~ AC	1~ AC
Application	LBP+MBP	LBP+MBP	LBP+MBP	LBP+MBP
Starting torque	HST	HST	HST	HST
Hot gas defrost	OK	OK	OK	OK
Long interval pull down	OK	OK	OK	OK
System cooling	fan 3m/s	fan 3m/s	fan 3m/s	fan 3m/s
Note	- / -			

## Controller functions

	<b>Conf. 1</b>	<b>Conf. 2</b>	<b>Conf. 3</b>	<b>Conf. 4</b>
Protection	Mechanic	Mechanic	Mechanic	Mechanic
Max output power	1000 W	1000 W	1000 W	1000 W
No of relays	2	2	2	8
Hot gas defrost	yes	yes	yes	yes
AEO speed setting	yes	yes	yes	N
Serial com, (Modbus)	SWI	SWI	SWI	RS485
DWI / Frequency input	yes	yes	yes	N
Note			US GFCI-Conformity	

## Model

Designation

**NLV12.6CN**

Sales code:

**105H6365**

## Compressor dimensions

<b>Housing</b>	A Height	203mm / 7,99in
	B Height	197mm / 7,76in
	C Length shell	205mm / 8,07in
	D Length w. cover	252mm / 9,92in
	E Width	166mm / 6,54in



Connectors		Suction	Discharge	Process
		X	Y	Z
Diameter	[mm]	øi 8,11-8,29	øi 6,11-6,29	øi 6,11-6,29
(i:inside, o:outside)	[in]	øi 0,32-0,33	øi 0,24-0,25	øi 0,24-0,25
Material		copper	copper	copper
Horizontal angle	±2°	0°	0°	0°
Vertical angle	±2°	15°	21°	155°
Position l/h/w	[mm]	132/69/57	94/102/81	-109/94/72
	[in]	5,2/2,7/2,2	3,7/4/3,2	-4,3/3,7/2,8
Straight tube l.	[mm]	12	12	12
	[in]	0,5	0,5	0,5

## Compressor fixation



### Bolt joint

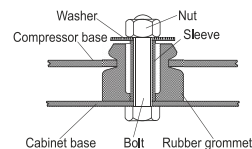

### Snap-on

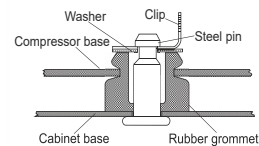

Mounting accessories	one comp.	multi pack
Bolt joint   M6   ø16mm	118-1917	118-1918
Bolt joint   ø1/4"   ø16mm	118-1946	
Bolt joint   ø1/4"   ø19mm	118-1949	
Snap-on   ø7,3   ø16mm	118-1947	118-1919

## Application notes

Operation possible until tilted up to 3 degrees

Provision for PE Grounding is located at the PE Stamp on the compressor

## Model

Designation	<b>NLV12.6CN</b>	<b>220-240V 50/60Hz</b>	<b>Conf. 1</b>	Sales code:	<b>105H6365</b>
<b>Controller</b>	<b>NLV MP 230V</b>				<b>105N4910</b>

Sales code single pack:	105N4910 (1 units)
Sales code industry pack:	105N4911 (8 units)
Adaption to compressor:	detached
Protection class:	IP54
Weight:	1.4 kg / 3.08 lbs
Voltage nom.:	220-240V 50/60Hz
Voltage range:	180-270 V
Max. current:	8,4 A (230 V)
LRA (Locked Rotor Amperage):	1,2 A
Cable length:	680 mm
Compressor speed range:	2000-4500 rpm
Housing plastic:	UL94-5VA

### Controller dimensions:



QR Code and Hyperlink leads to the [Operating Instructions.](#)

## Operation Limits

Suctiongas temperature < +20°C (continuous operation)

## System cooling

### Ambient/ machineroom temperatures minimum /maximum

Ambient temperature range:	10 - 43°C / 50 - 110°F
Machine room temperature range compressor:	10 - 48°C / 50 - 119°F
Machine room temperature range controller:	10 - 50°C / 50 - 122°F

**Compressor and Controller Cooling:** Fan cooling 3m/s

Ensure proper airflow of 3 m/s at both compressor and electronic units.

The airflow for the electronics must be directed to the heat sink.



## Operation pressure range

R290



### Model

Designation	NLV12.6CN	220-240V 50/60Hz	Conf. 1	Sales code:	105H6365
-------------	-----------	------------------	---------	-------------	----------

Controller	NLV MP 230V				105N4910
------------	-------------	--	--	--	----------

### Controller connections

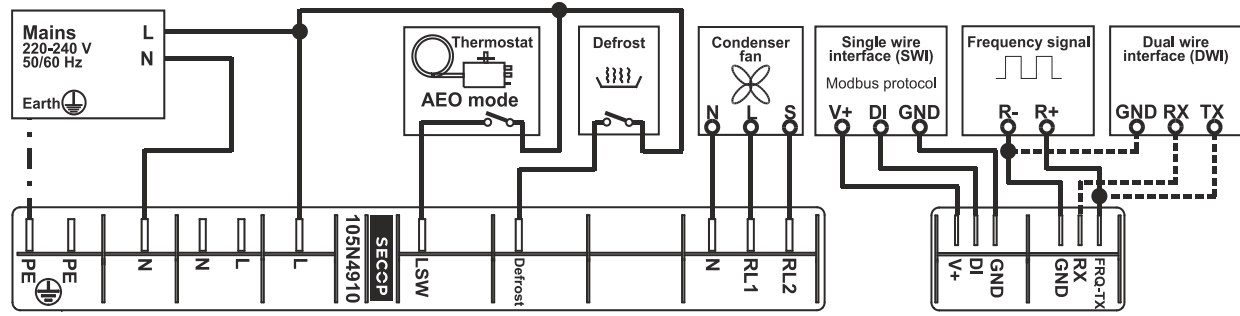
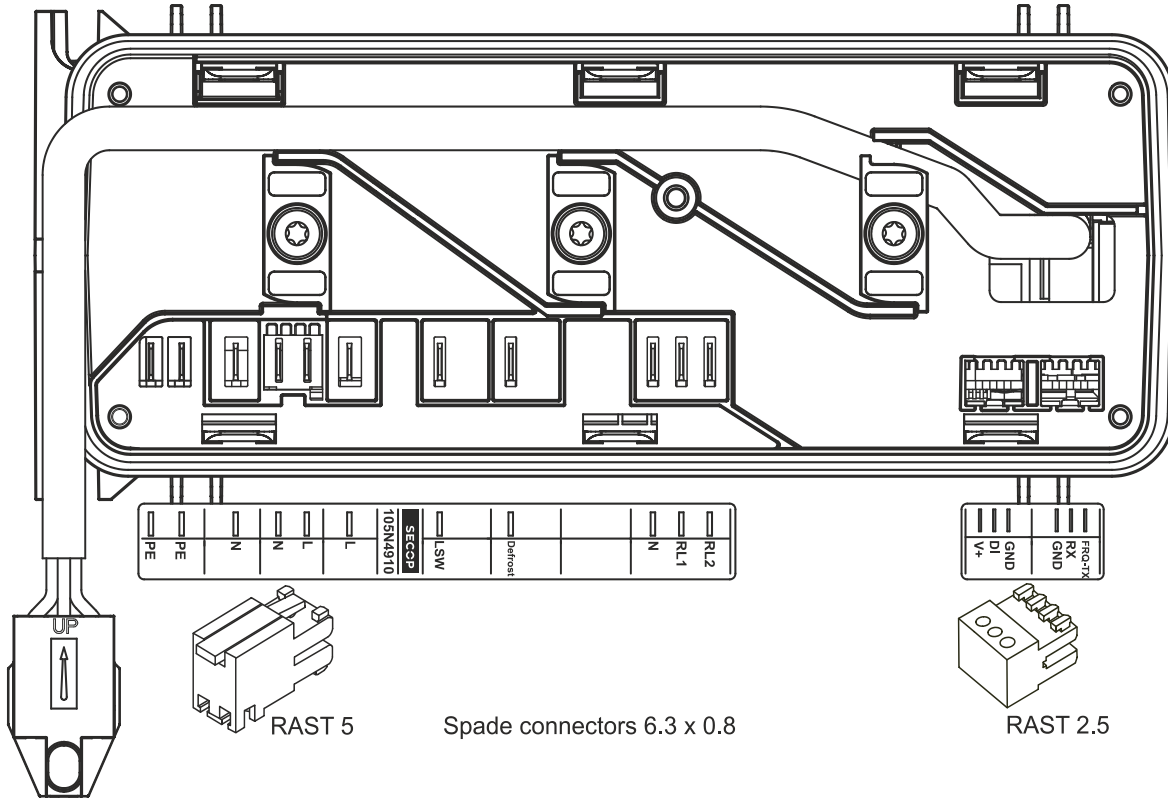

### Accessories (Compressor + Controller) - check operation manual for details

103N2008	plastic cover	1 pcs
103N9110	plastic cover (MP of 103N2008)	80 pcs

### Model

Designation	<b>NLV12.6CN</b>	<b>220-240V 50/60Hz</b>	<b>Conf. 1</b>	Sales code:	<b>105H6365</b>
Controller	<b>NLV MP 230V</b>				<b>105N4910</b>

### Optimization + standard conditions

R290, 220V, 50Hz, Rpm\_N 4500, fan 3m/s

	Evaporating pressure (saturation temperature)				Condensing pressure (saturation temperature)						Power consumption			ASHRAE LBP
	pe	pc	Return gas temp.		Cooling capacity			COP	EER	P1	Current consumption		Ref. mass flow	
			RGT	Tliq	[W]	[Btu/h]	[kcal/h]				I	m		
	[°C]	[°F]	[°C]	[°C]	[W]	[Btu/h]	[kcal/h]	[W/W]	[Btu/Wh]	[kcal/Wh]	[W]	[A]	[kg/h]	
	-23	54	32	32	948,7	3240	816,5	1,78	6,07	1,53	534,1	2,90	9,61	ASHRAE LBP
	-10	130	90	90										
	-25	55	32	55	711,3	2429	612,2	1,39	4,73	1,19	513,5	2,79	8,86	cecomaf LBP
	-13	131	90	131										
	-35	40	20	40	543,4	1856	467,7	1,51	5,16	1,30	359,9	1,96	6,21	EN12900 LBP
	-31	104	68	104										
	-7	54	35	46	1677,8	5730	1443,9	2,18	7,46	1,88	768,0	4,17	19,14	ASHRAE MBP
	20	130	95	115										
	-10	55	32	55	1335,8	4562	1149,6	1,84	6,30	1,59	724,1	3,94	16,90	cecomaf MBP
	14	131	90	131										
	-10	45	20	45	1501,8	5129	1292,5	2,30	7,84	1,98	654,2	3,56	18,44	EN12900 MBP
	14	113	68	113										

### Standard conditions with different RPM

R290, 220V, 50Hz, Rpm\_N 4500, fan 3m/s

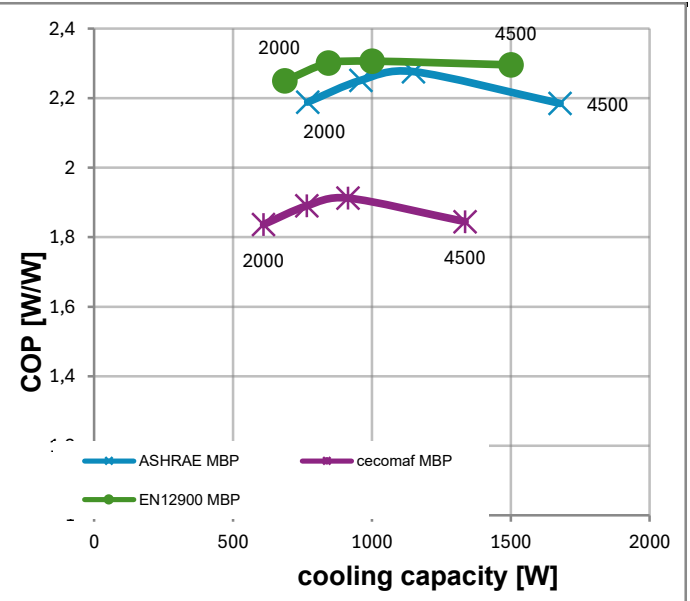
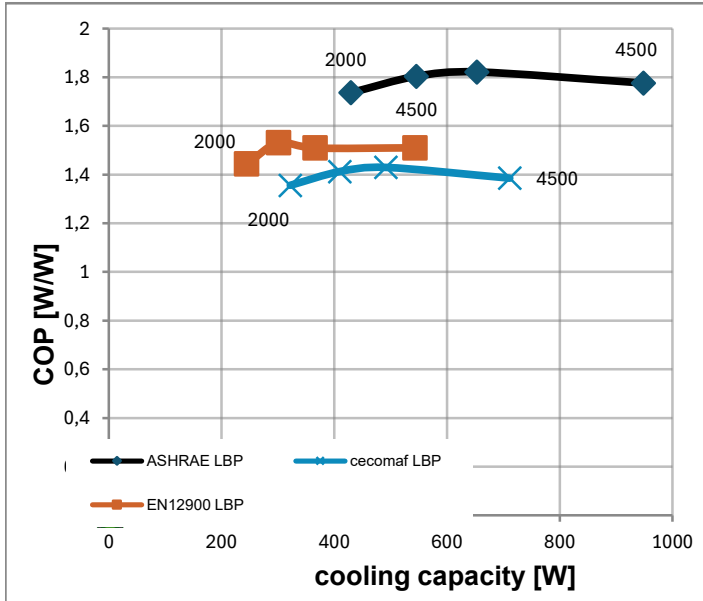

### Test conditions:

	pe [°C]	pc [°C]	Tliq [°C]	Tsuc [°C]		pe [°C]	pc [°C]	Tliq [°C]	Tsuc [°C]
ASHRAE LBP	-23,33	54,44	32,22	32,22	ASHRAE MBP	-6,66	54,44	46,11	35
cecomaf LBP	-25	55	55	32	cecomaf MBP	-10	55	55	32
EN12900 LBP	-35	40	40	20	EN12900 MBP	-10	45	45	20

## Model

Designation	<b>NLV12.6CN</b>	<b>100-240V 50/60Hz</b>	<b>Conf. 2</b>	Sales code:	<b>105H6365</b>
<b>Controller</b>	<b>NLV MP MV</b>				<b>105N4960</b>

Sales code single:	105N4960 (1 units)
Sales code industry pack:	105N4961 (8 units)
Adaption to compressor:	detached
Protection class:	IP54
Weight:	1.4 kg / 3.08 lbs
Voltage nom.	100-240V 50/60Hz
Voltage range	90-150/180-270 V
Max. current:	4,2 A (230 V) / 8,4 A (115 V)
LRA (Locked Rotor Amperage):	1,2 A
Cable length:	680 mm
Compressor speed range:	2000-4500 rpm
Housing plastic:	UL94-5VA

### Controller dimensions:

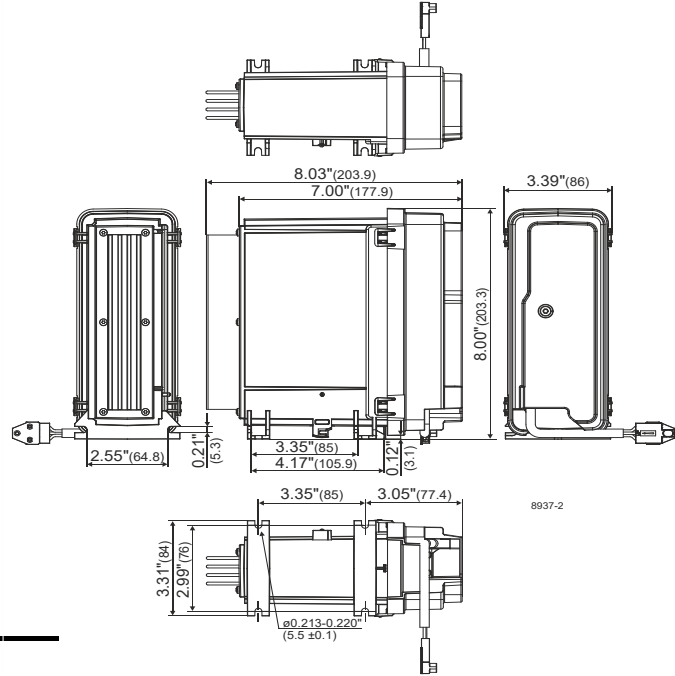

QR Code and Hyperlink leads to the [Operating Instructions.](#)

## Operation Limits

Suctiongas temperature < +20°C (continuous operation)

## System cooling

### Ambient/ machineroom temperatures minimum /maximum

Ambient temperature range:	10 - 43°C / 50 - 110°F
Machine room temperature range compressor:	10 - 48°C / 50 - 119°F
Machine room temperature range controller:	10 - 50°C / 50 - 122°F

**Compressor and Controller Cooling:** Fan cooling 3m/s

Ensure proper airflow of 3 m/s at both compressor and electronic units.

The airflow for the electronics must be directed to the heat sink.

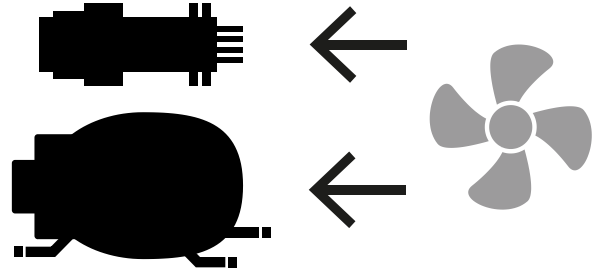

## Operation pressure range

R290

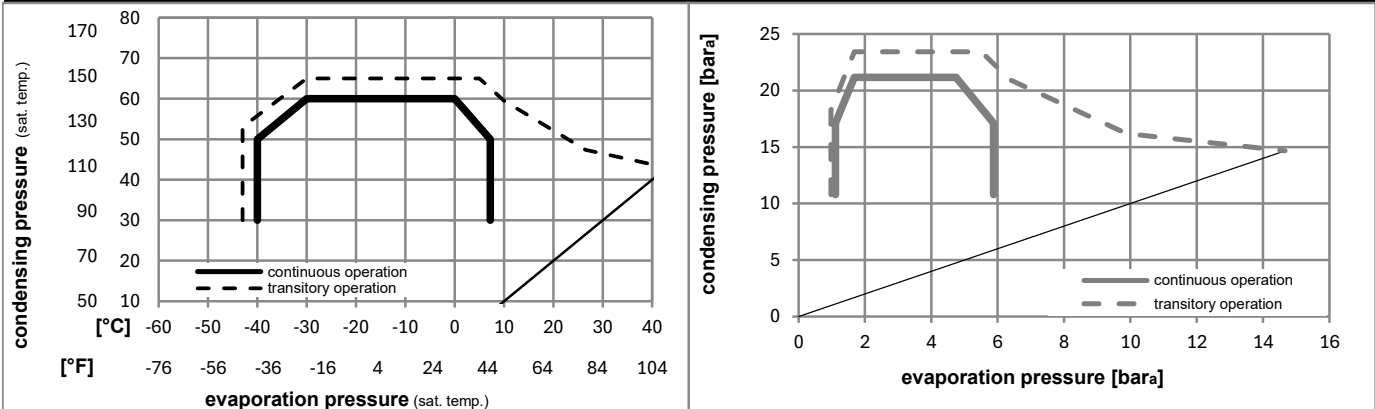

## Model

Designation **NLV12.6CN** **100-240V 50/60Hz** **Conf. 2** Sales code: **105H6365**

Controller **NLV MP MV** **105N4960**

## Controller connections

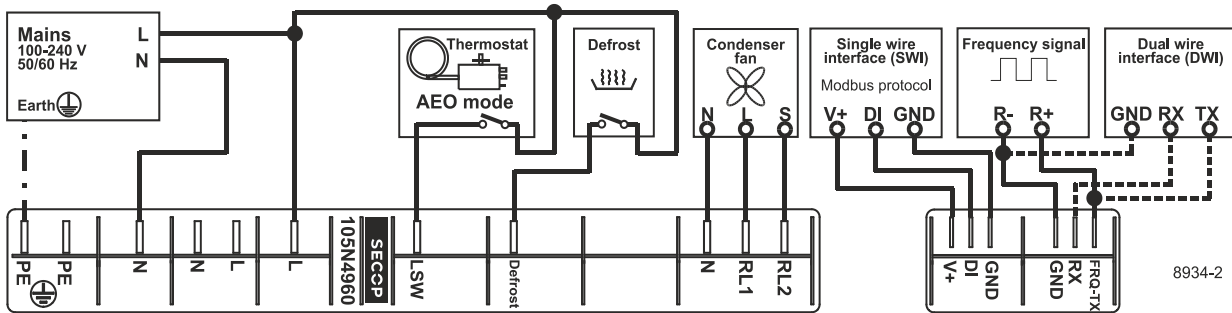
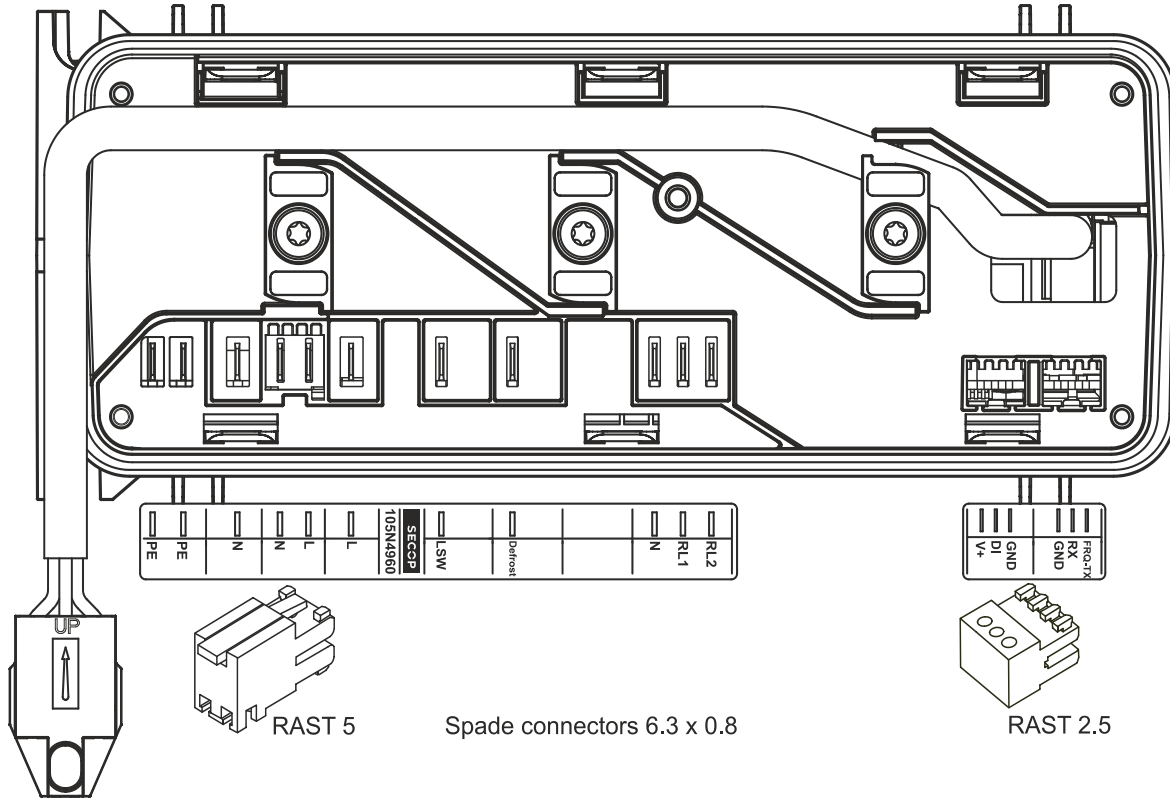

## Accessories (Compressor + Controller) - check operation manual for details

103N2008	plastic cover	1 pcs
103N9110	plastic cover (MP of 103N2008)	80 pcs



### Model

Designation **NLV12.6CN** **100-240V 50/60Hz** **Conf. 2** Sales code: **105H6365**

Controller **NLV MP MV** **105N4960**

### Optimization + standard conditions

R290, 220V, 50Hz, Rpm\_N 4500, fan 3m/s

	Evaporating pressure (saturation temperature)				Condensing pressure (saturation temperature)			COP	EER	Power consumption	Current consumption		Ref. mass flow	
	pe	pc	RGT	Tliq	W	[Btu/h]	[kcal/h]				P1	I		
	[°C]	[°F]	[°C]	[°F]	[W]	[Btu/h]	[kcal/h]	[W/W]	[Btu/Wh]	[kcal/Wh]	[W]	[A]	[kg/h]	
	-23	54	32	32	948,7	3240	816,5	1,78	6,07	1,53	534,1	2,90	9,61	ASHRAE LBP
	-10	130	90	90										
	-25	55	32	55	711,3	2429	612,2	1,39	4,73	1,19	513,5	2,79	8,86	cecomaf LBP
	-13	131	90	131										
	-35	40	20	40	543,4	1856	467,7	1,51	5,16	1,30	359,9	1,96	6,21	EN12900 LBP
	-31	104	68	104										
	-7	54	35	46	1677,8	5730	1443,9	2,18	7,46	1,88	768,0	4,17	19,14	ASHRAE MBP
	20	130	95	115										
	-10	55	32	55	1335,8	4562	1149,6	1,84	6,30	1,59	724,1	3,94	16,90	cecomaf MBP
	14	131	90	131										
	-10	45	20	45	1501,8	5129	1292,5	2,30	7,84	1,98	654,2	3,56	18,44	EN12900 MBP
	14	113	68	113										

### Standard conditions with different RPM

R290, 220V, 50Hz, fan 3m/s

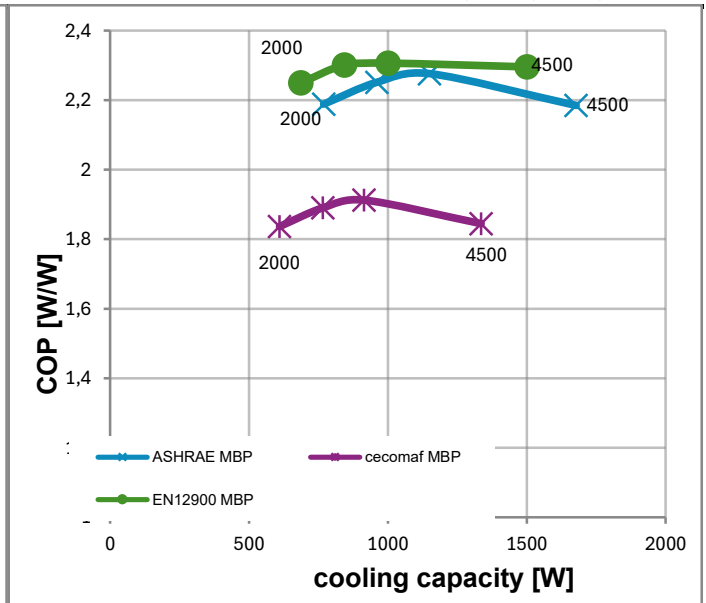
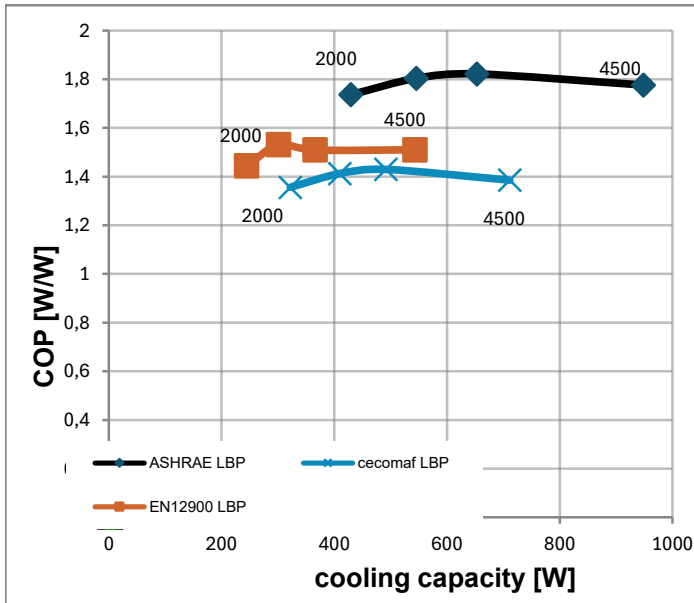

Test conditions:	pe [°C]	pc [°C]	Tliq [°C]	Tsuc [°C]
ASHRAE LBP	-23,33	54,44	32,22	32,22
cecomaf LBP	-25	55	55	32
EN12900 LBP	-35	40	40	20

Test conditions:	pe [°C]	pc [°C]	Tliq [°C]	Tsuc [°C]
ASHRAE MBP	-6,66	54,44	46,11	35
cecomaf MBP	-10	55	55	32
EN12900 MBP	-10	45	45	20

## Model

Designation	<b>NLV12.6CN</b>	<b>100-240V 50/60Hz</b>	<b>Conf. 3</b>	Sales code:	<b>105H6365</b>
<b>Controller</b>	<b>NLV MP MV GFCI</b>				<b>105N4962</b>

Sales code single:	105N4962 (1 units)
Sales code industry pack:	105N4963 (8 units)
Adaption to compressor:	detached
Protection class:	IP54
Weight:	1.4 kg / 3.08 lbs
Voltage nom.	100-240V 50/60Hz
Voltage range	90-150/180-270 V
Max. current:	4,2 A (230 V) / 8,4 A (115 V)
LRA (Locked Rotor Amperage):	1,2 A
Cable length:	915 mm
Compressor speed range:	2000-4500 rpm
Housing plastic:	UL94-5VA

### Controller dimensions:

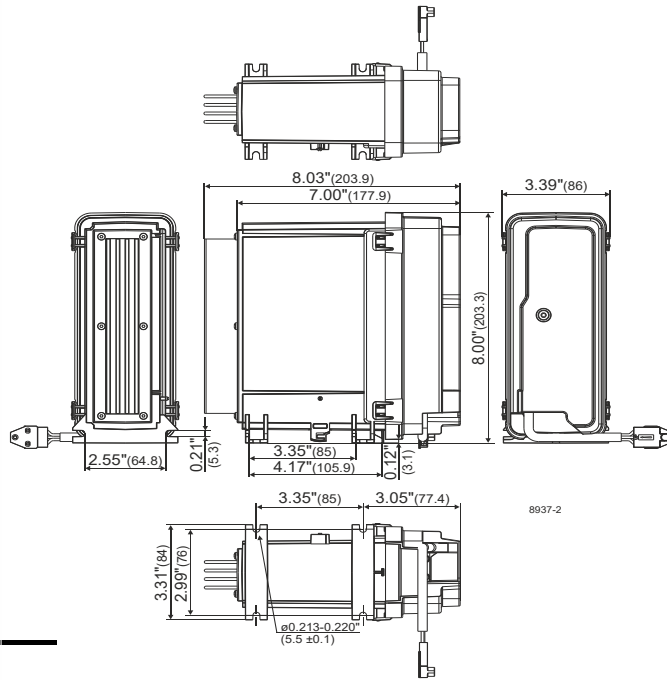

QR Code and Hyperlink leads to the [Operating Instructions.](#)

## Operation Limits

Suctiongas temperature < +20°C (continuous operation)

## System cooling

### Ambient/ machineroom temperatures minimum /maximum

Ambient temperature range:	10 - 43°C / 50 - 110°F
Machine room temperature range compressor:	10 - 48°C / 50 - 119°F
Machine room temperature range controller:	10 - 50°C / 50 - 122°F

**Compressor and Controller Cooling:** Fan cooling 3m/s

Ensure proper airflow of 3 m/s at both compressor and electronic units.

The airflow for the electronics must be directed to the heat sink.

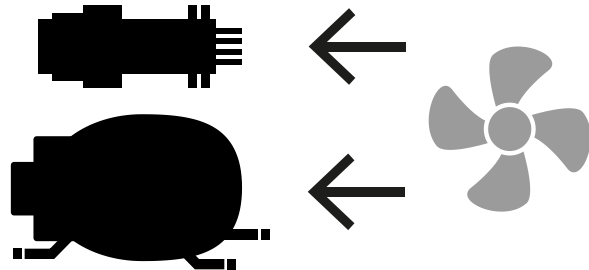

## Operation pressure range

R290

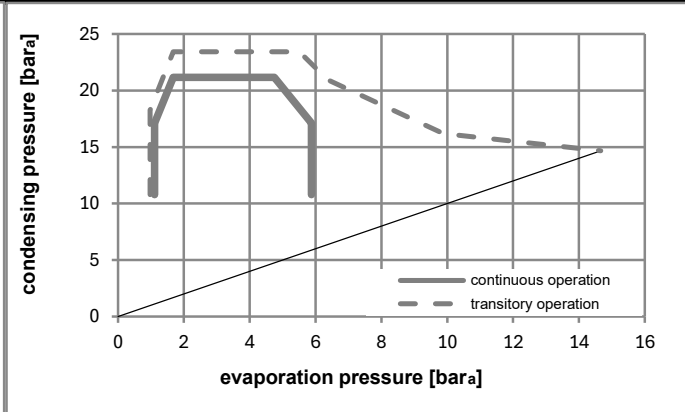
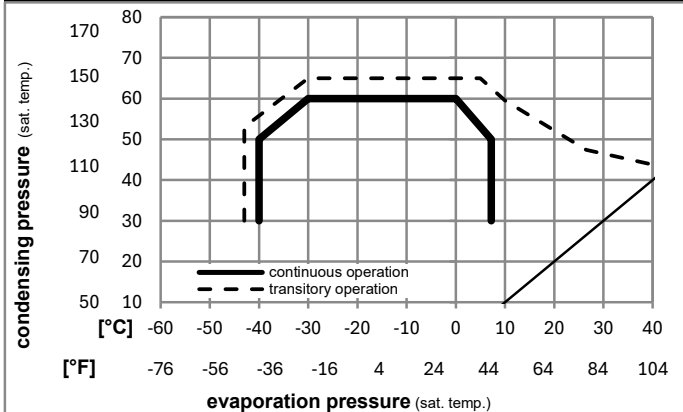

### Model

Designation	NLV12.6CN	100-240V 50/60Hz	Conf. 3	Sales code:	105H6365
-------------	-----------	------------------	---------	-------------	----------

Controller	NLV MP MV GFCI	105N4962
------------	----------------	----------

### Controller connections

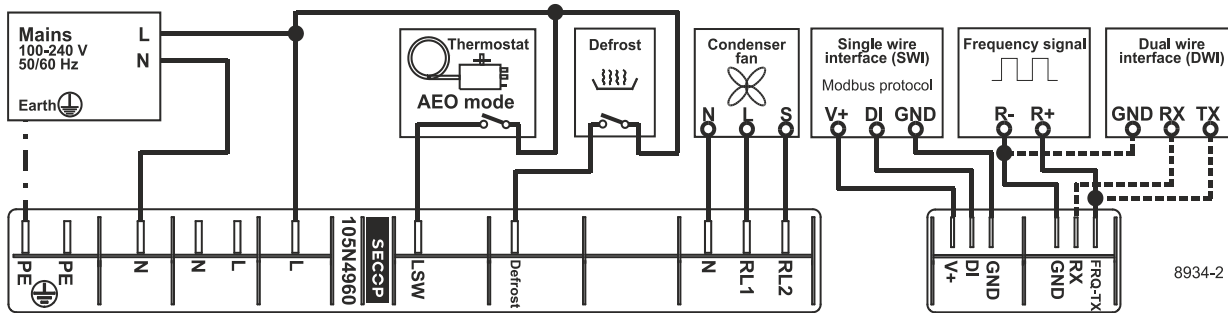
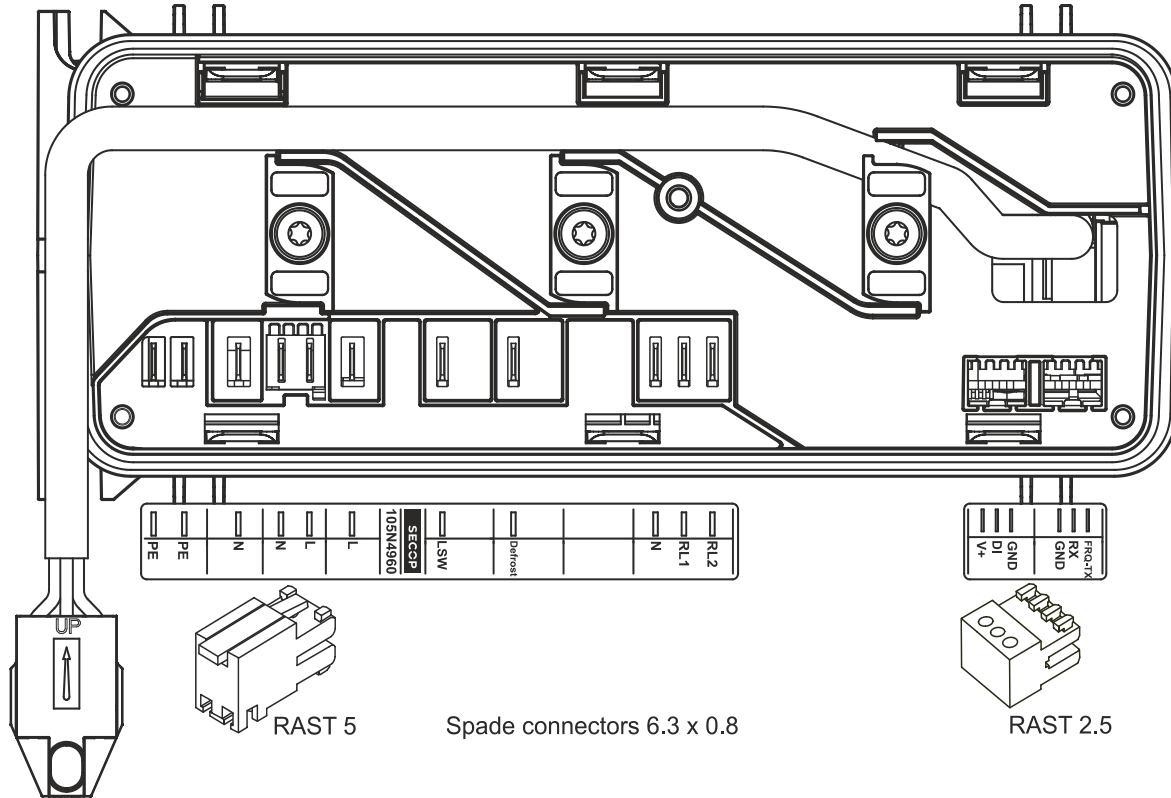

### Accessories (Compressor + Controller) - check operation manual for details

103N2008	plastic cover	1 pcs
103N9110	plastic cover (MP of 103N2008)	80 pcs

### Model

Designation **NLV12.6CN** **100-240V 50/60Hz** **Conf. 3** Sales code: **105H6365**

Controller **NLV MP MV GFCI** **105N4962**

### Optimization + standard conditions

R290, 220V, 50Hz, Rpm\_N 4500, fan 3m/s

	Evaporating pressure (saturation temperature)				Condensing pressure (saturation temperature)			COP	EER	Power consumption	Current consumption		Ref. mass flow			
	pe	pc	RGT	Tliq	Return gas temp.	Liquid temp.	W				[Btu/h]	[kcal/h]			P1	I
	[°C]	[°C]	[°C]	[°C]	[°C]	[°C]	[W]	[Btu/h]	[kcal/h]	[W/W]	[Btu/Wh]	[kcal/Wh]	[W]	[A]	[kg/h]	
	-23	54	32	32			948,7	3240	816,5	1,78	6,07	1,53	534,1	2,90	9,61	ASHRAE LBP
	-10	130	90	90												
	-25	55	32	55			711,3	2429	612,2	1,39	4,73	1,19	513,5	2,79	8,86	cecomaf LBP
	-13	131	90	131												
	-35	40	20	40			543,4	1856	467,7	1,51	5,16	1,30	359,9	1,96	6,21	EN12900 LBP
	-31	104	68	104												
	-7	54	35	46			1677,8	5730	1443,9	2,18	7,46	1,88	768,0	4,17	19,14	ASHRAE MBP
	20	130	95	115												
	-10	55	32	55			1335,8	4562	1149,6	1,84	6,30	1,59	724,1	3,94	16,90	cecomaf MBP
	14	131	90	131												
	-10	45	20	45			1501,8	5129	1292,5	2,30	7,84	1,98	654,2	3,56	18,44	EN12900 MBP
	14	113	68	113												

### Standard conditions with different RPM

R290, 220V, 50Hz, fan 3m/s

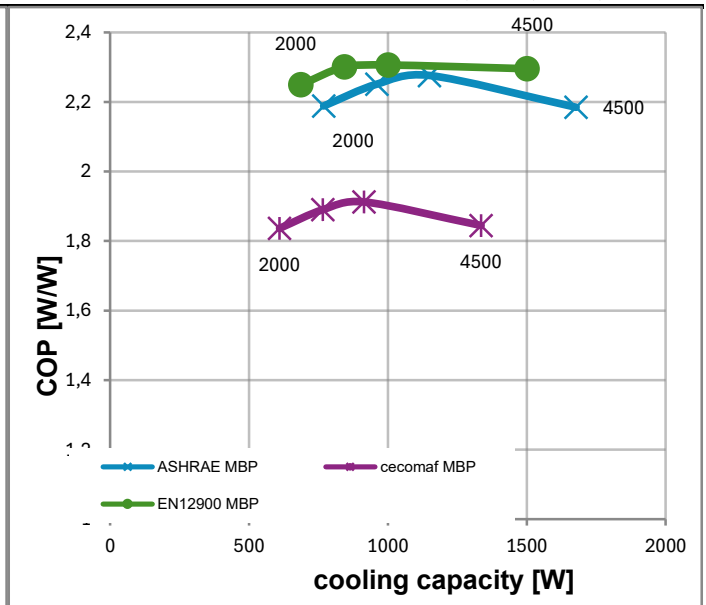
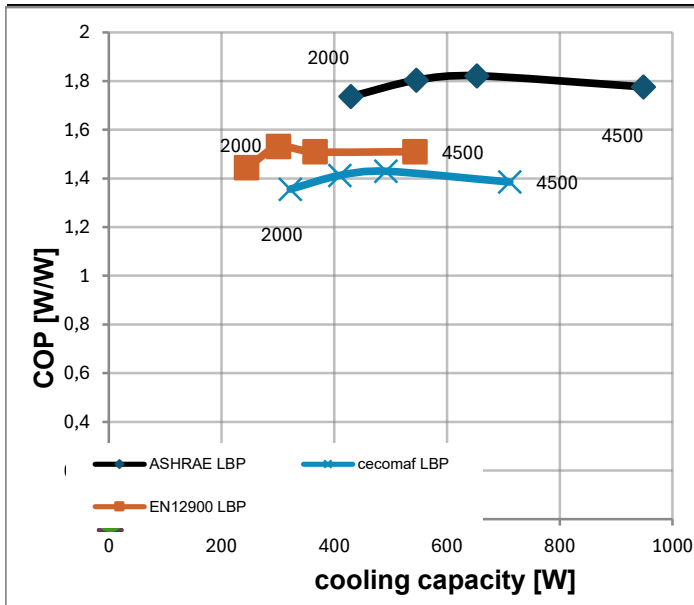

Test conditions:	pe [°C]	pc [°C]	Tliq [°C]	Tsuc [°C]
ASHRAE LBP	-23,33	54,44	32,22	32,22
cecomaf LBP	-25	55	55	32
EN12900 LBP	-35	40	40	20

Test conditions:	pe [°C]	pc [°C]	Tliq [°C]	Tsuc [°C]
ASHRAE MBP	-6,66	54,44	46,11	35
cecomaf MBP	-10	55	55	32
EN12900 MBP	-10	45	45	20

## Model

Designation	<b>NLV12.6CN</b>	<b>100-240V 50/60Hz1~ AC</b>	<b>Conf. 4</b>	Sales code:	<b>105H6365</b>
<b>Controller</b>	<b>NLV XT MV</b>				<b>105N4866</b>

Sales code single:	105N4866 (1 units)
Sales code industry pack:	105N4867 (8 units)
Adaption to compressor:	detached
Protection class:	IP43
Weight:	1.5 kg / 3.3 lbs
Voltage nom.	100-240V 50/60Hz1~ AC
Voltage range	90-150/180-270 V
Max. current:	4,2 A (230 V) / 8,4 A (115 V)
LRA (Locked Rotor Amperage):	1,2 A
Cable length:	630 mm
Compressor speed range:	2000-4500 rpm
Housing plastic:	UL94-5VA

### Controller dimensions:



QR Code and Hyperlink leads to the [Operating Instructions.](#)

## Operation Limits

Suctiongas temperature < +20°C (continuous operation)

## System cooling

### Ambient/ machineroom temperatures minimum /maximum

Ambient temperature range:	10 - 43°C / 50 - 110°F
Machine room temperature range compressor:	10 - 48°C / 50 - 119°F
Machine room temperature range controller:	10 - 50°C / 50 - 122°F

**Compressor and Controller Cooling:** Fan cooling 3m/s

Ensure proper airflow of 3 m/s at both compressor and electronic units.

The airflow for the electronics must be directed to the heat sink.

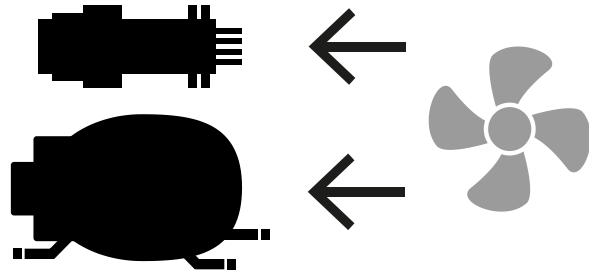

## Operation pressure range

R290

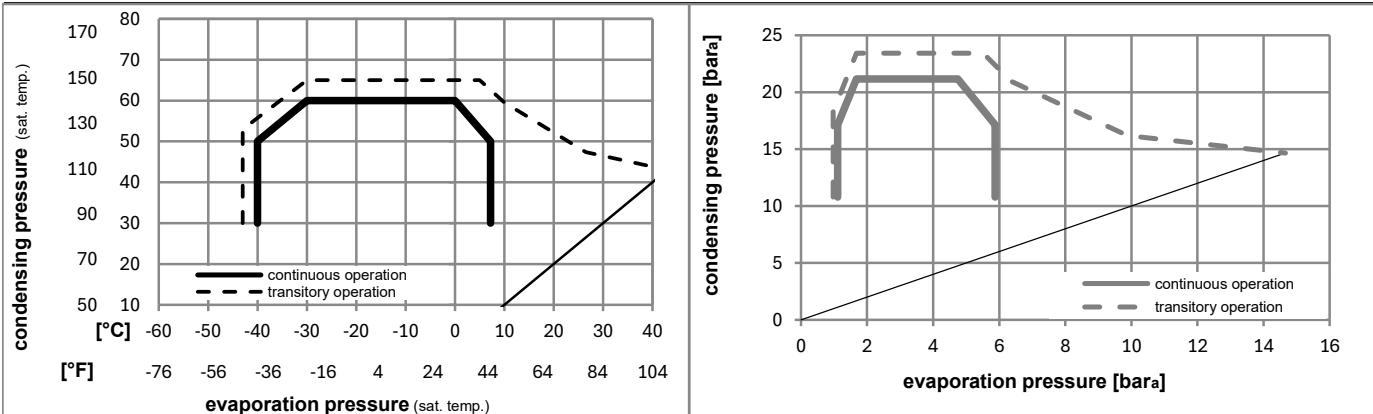

## Model

Designation **NLV12.6CN** **100-240V 50/60Hz1~ AC** **Conf. 4** Sales code: **105H6365**

Controller **NLV XT MV** **105N4866**

## Controller connections

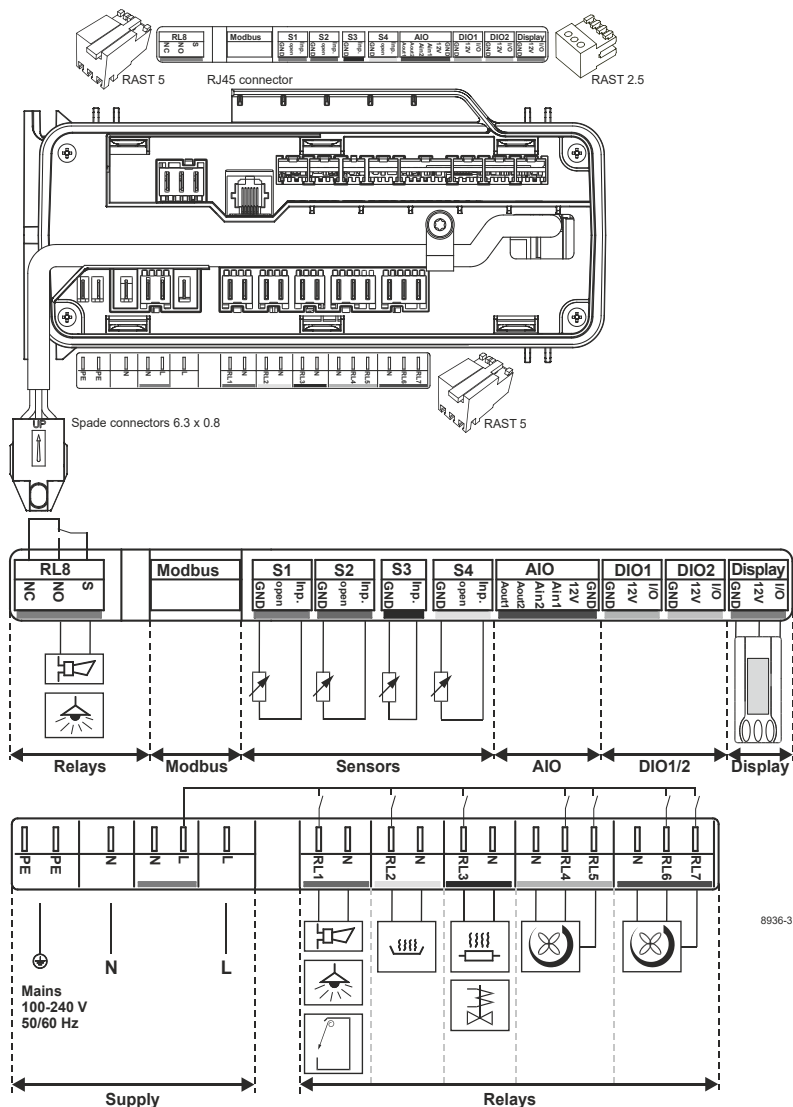

## Accessories (Compressor + Controller) - check operation manual for details

103N2008	plastic cover	1 pcs
103N9110	plastic cover (MP of 103N2008)	80 pcs

### Model

Designation	<b>NLV12.6CN</b>	<b>100-240V 50/60Hz1~ AC</b>	<b>Conf. 4</b>	Sales code:	<b>105H6365</b>
Controller	<b>NLV XT MV</b>				<b>105N4866</b>

### Optimization + standard conditions

R290, 220V, 50Hz, Rpm\_N 4500, fan 3m/s

	Evaporating pressure (saturation temperature)				Condensing pressure (saturation temperature)			COP	EER		Power consumption					
	pe	pc	RGT	Tliq	Return gas temp.	Liquid temp.	Cooling capacity				P1	I	Ref. mass flow			
	[°C]	[°F]	[°C]	[°F]	[°C]	[°F]	[W]	[Btu/h]	[kcal/h]	[W/W]	[Btu/Wh]	[kcal/Wh]	[W]	[A]	[kg/h]	
	-23	54	32	32	948,7	3240	816,5	1,78	6,07	1,53	534,1	2,90	9,61		<b>ASHRAE LBP</b>	
	-10	130	90	90												
	-25	55	32	55	711,3	2429	612,2	1,39	4,73	1,19	513,5	2,79	8,86		<b>cecomaf LBP</b>	
	-13	131	90	131												
	-35	40	20	40	543,4	1856	467,7	1,51	5,16	1,30	359,9	1,96	6,21		<b>EN12900 LBP</b>	
	-31	104	68	104												
	-7	54	35	46	1677,8	5730	1443,9	2,18	7,46	1,88	768,0	4,17	19,14		<b>ASHRAE MBP</b>	
	20	130	95	115												
	-10	55	32	55	1335,8	4562	1149,6	1,84	6,30	1,59	724,1	3,94	16,90		<b>cecomaf MBP</b>	
	14	131	90	131												
	-10	45	20	45	1501,8	5129	1292,5	2,30	7,84	1,98	654,2	3,56	18,44		<b>EN12900 MBP</b>	
	14	113	68	113												

### Standard conditions with different RPM

R290, 220V, 50Hz, fan 3m/s

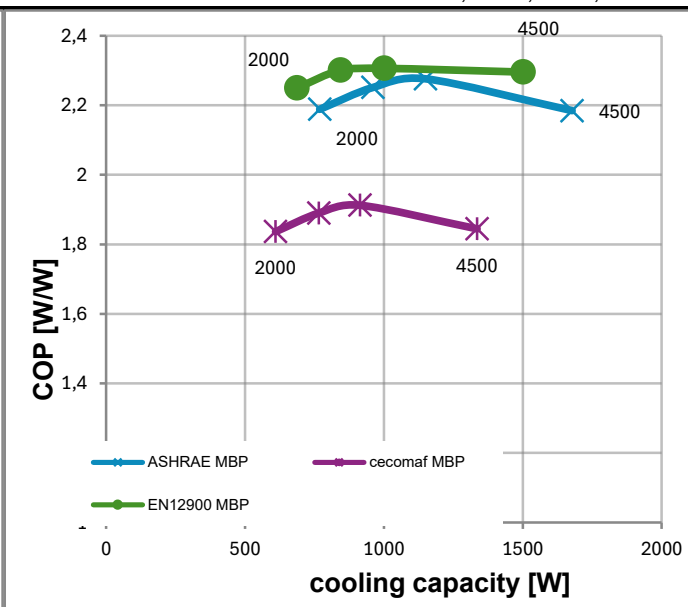
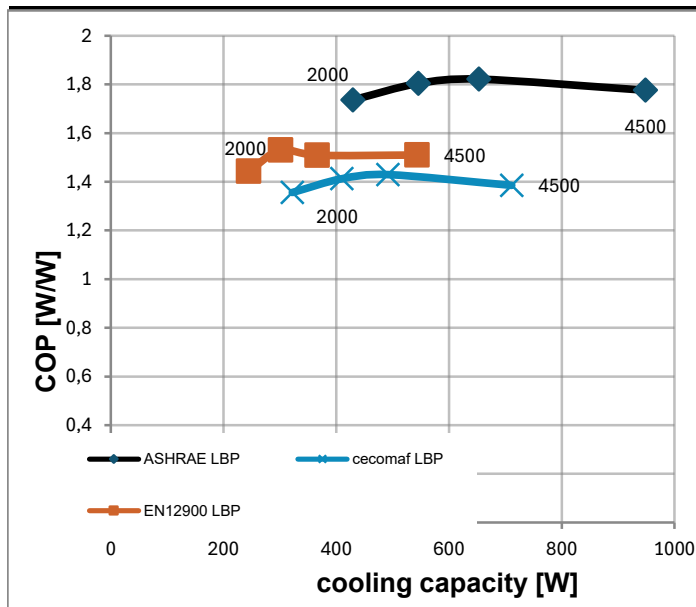

Test conditions:	pe [°C]	pc [°C]	Tliq [°C]	Tsuc [°C]	pe [°C]	pc [°C]	Tliq [°C]	Tsuc [°C]	
ASHRAE LBP	-23,33	54,44	32,22	32,22	ASHRAE MBP	-6,66	54,44	46,11	35
cecomaf LBP	-25	55	55	32	cecomaf MBP	-10	55	55	32
EN12900 LBP	-35	40	40	20	EN12900 MBP	-10	45	45	20

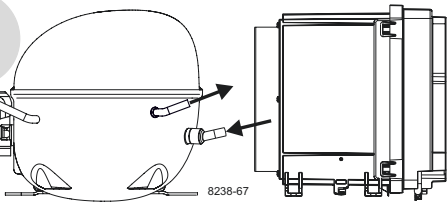

8238-67

# Instructions

NLV Compressors  
220-240V 50/60Hz  
105N491x Series  
Controllers

# SECCP



TOOL4COOL®



°CCD®

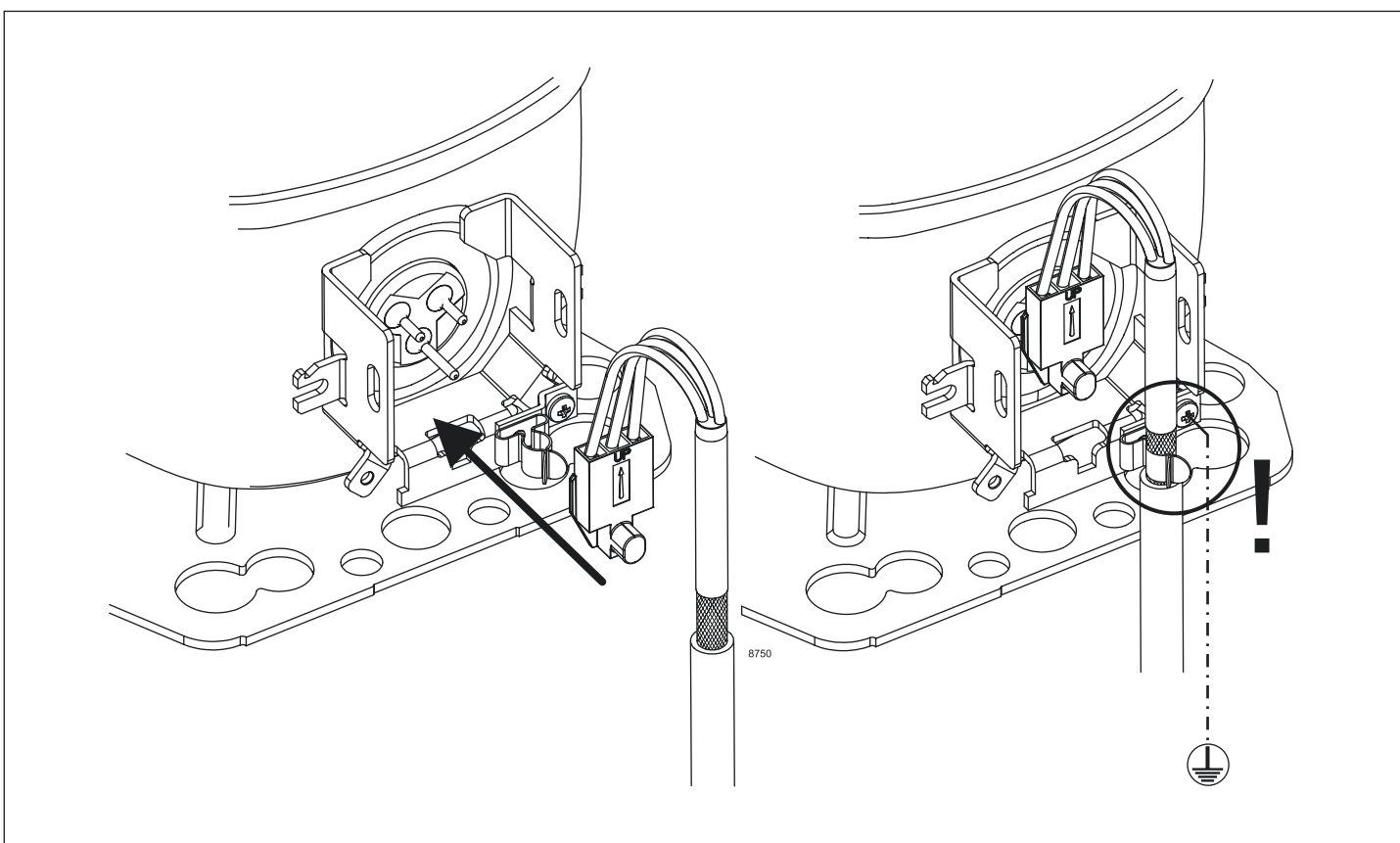
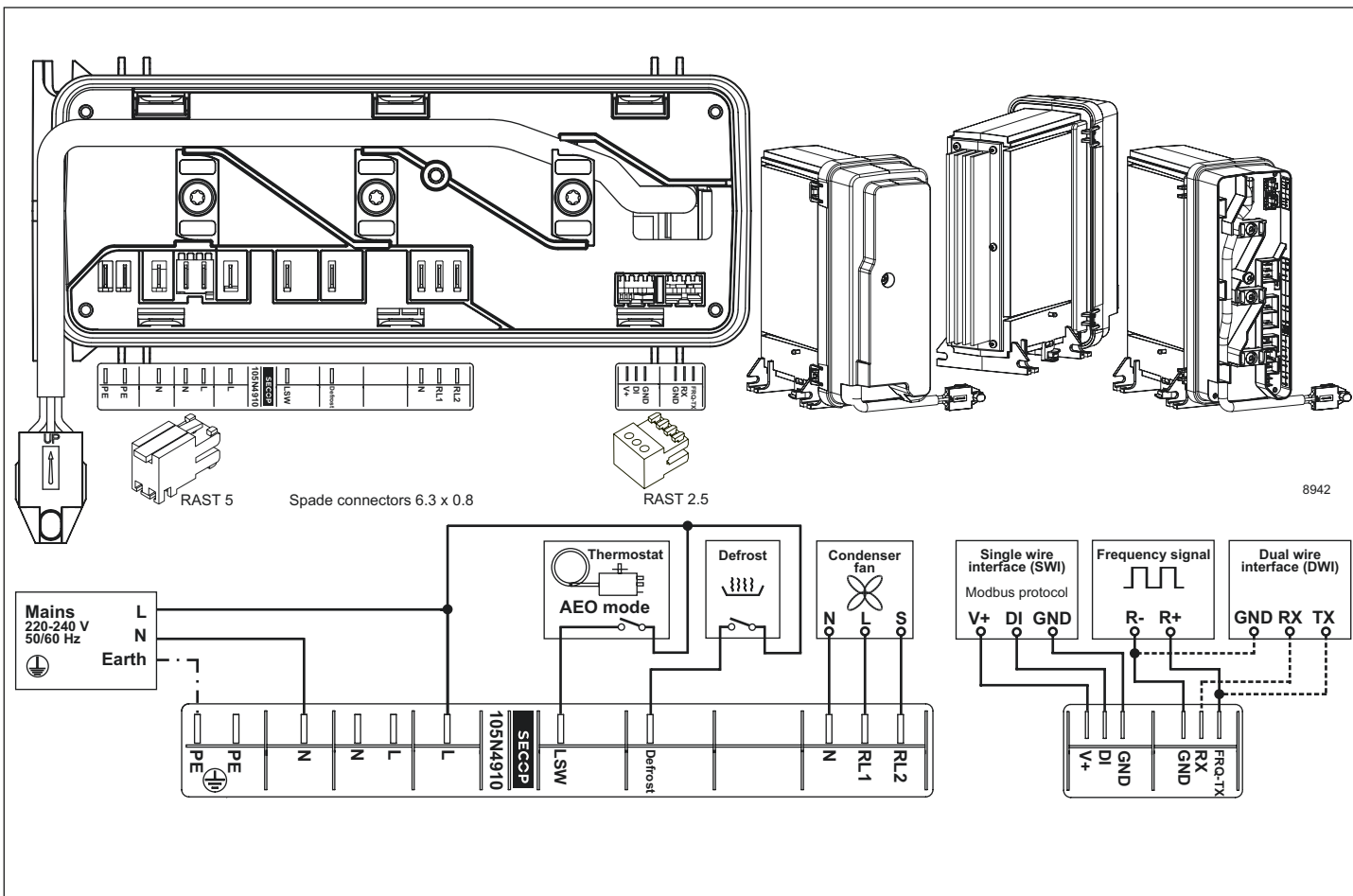



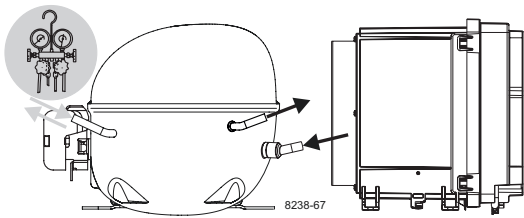

# Instructions

NLV Compressors  
220-240V 50/60Hz  
105N491x Series  
Controllers

**SECCP**



## Service/Repair R290

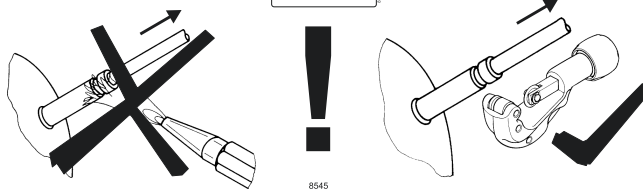

## Brazing on Suction Connectors (Direct Intake)

representative image

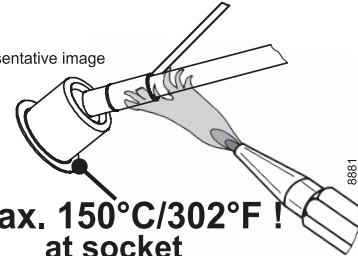

**! max. 150°C/302°F!  
at socket**

brazing solder: phosphor (LP7) or silver

Refer to Product Bulletin: **Brazing on Suction Connectors  
(Compressors with Direct Suction Intake)**

**min. 3 m/s !**

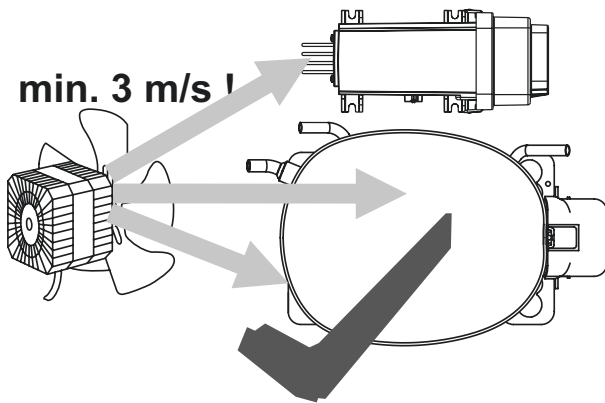

**min. 3 m/s !**

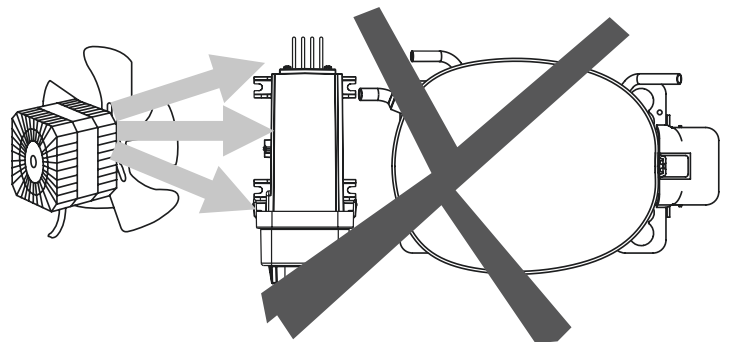
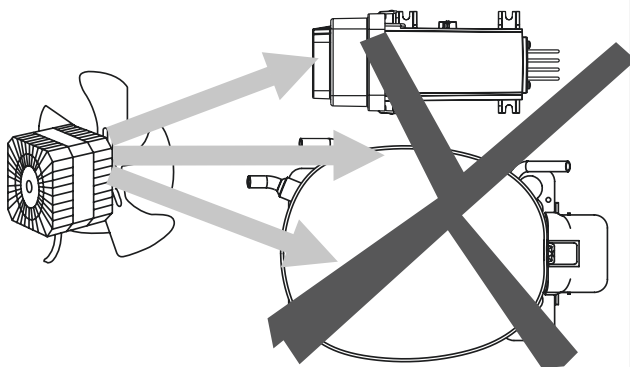
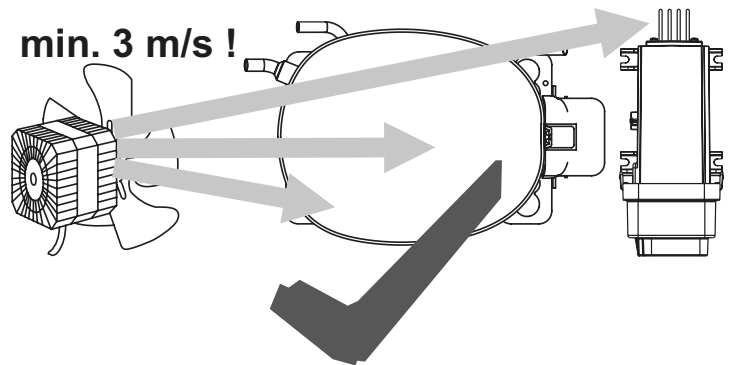

8938

<b>Airflow</b>	3 m/s
<b>Operating conditions</b>	+ 5 °C to 43 °C - humidity < 90 % rH non condensing
<b>Storage conditions</b>	-25 °C to 70 °C - humidity < 90 % rH non condensing
<b>Supply voltage</b>	220-240 V (± 10 %)
<b>Frequency</b>	50/60 Hz
<b>Input power, max.</b>	1000 W

Secop accepts no responsibility for possible errors in catalogs, brochures, and other printed material. Secop reserves the right to alter its products without notice. This also applies to products already on order provided that such alterations can be made without subsequent changes being necessary to specifications already agreed. All trademarks in this material are the property of the respective companies. Secop and the Secop logotype are trademarks of Secop GmbH. All rights reserved. [www.secop.com](http://www.secop.com)



# Instructions

NLV Compressors  
100-240V 50/60Hz  
105N496x Series  
Controllers

# SECCP

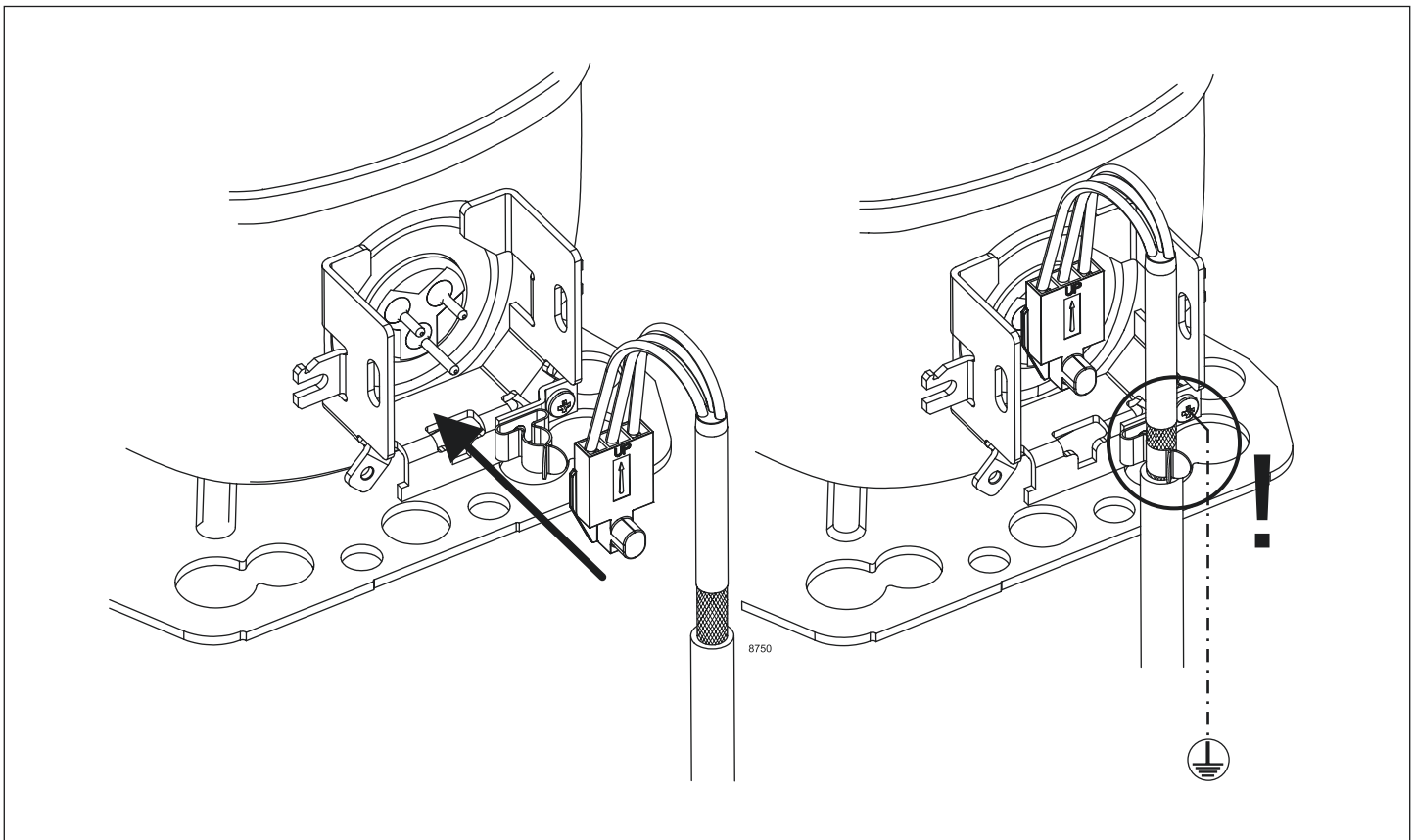
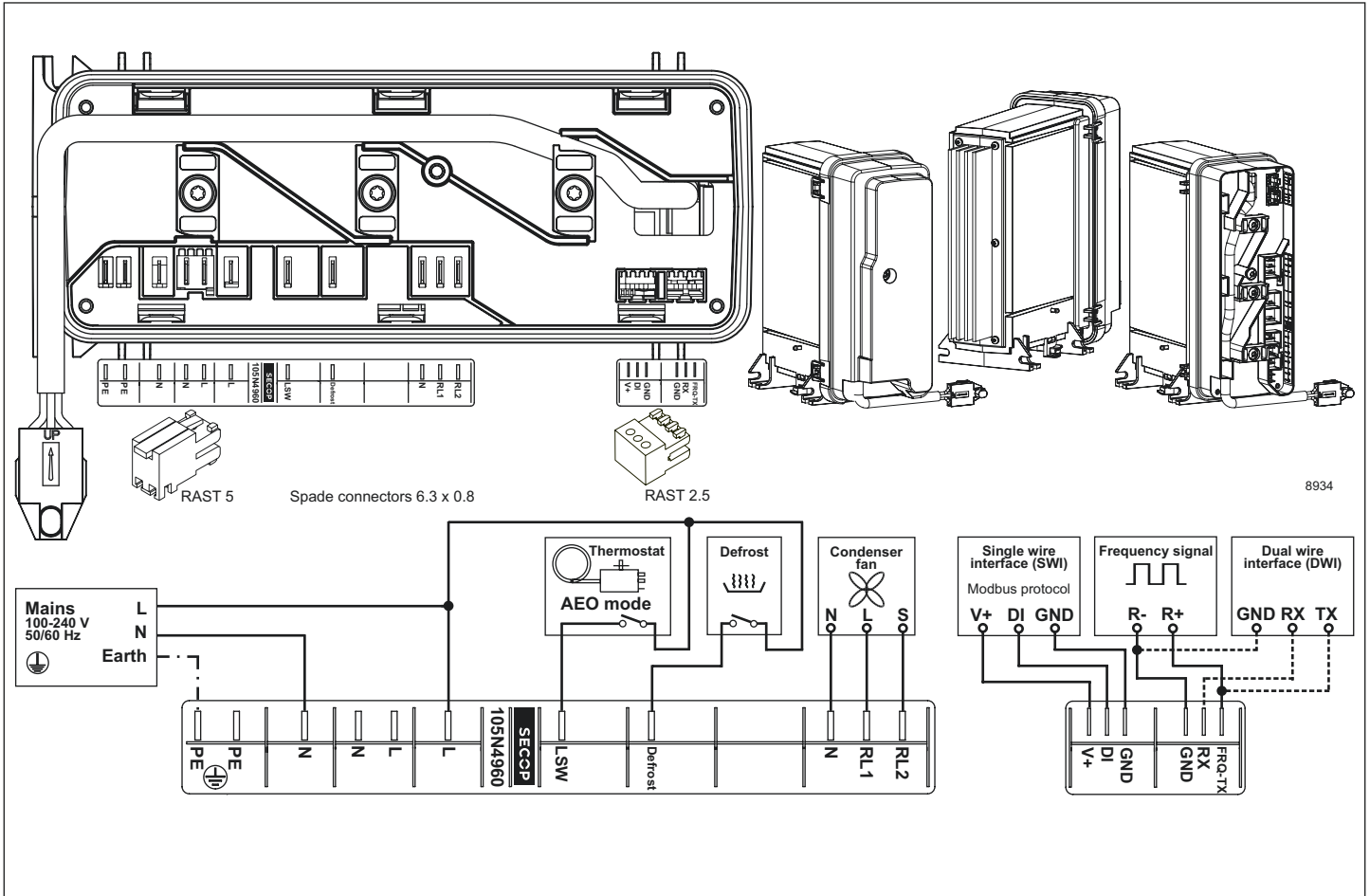



# Instructions

NLV Compressors  
100-240V 50/60Hz  
105N496x Series  
Controllers

# SECCP



## Service/Repair R290

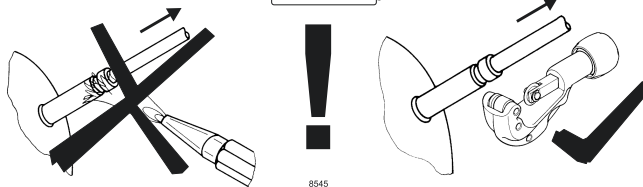

## Brazing on Suction Connectors (Direct Intake)

representative image

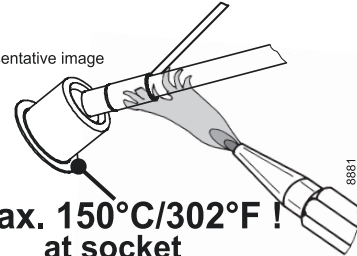

**! max. 150°C/302°F!  
at socket**

brazing solder: phosphor (LP7) or silver

Refer to Product Bulletin: **Brazing on Suction Connectors  
(Compressors with Direct Suction Intake)**

**min. 3 m/s !**

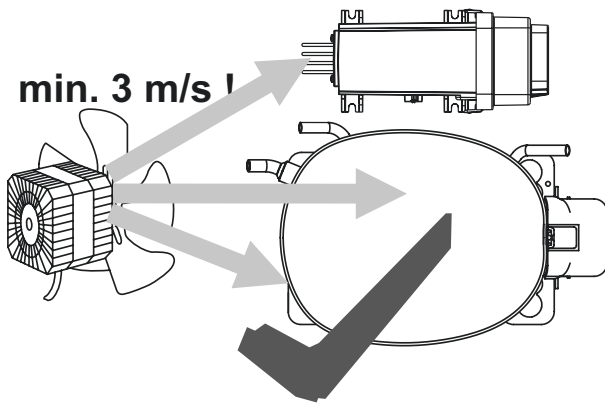

**min. 3 m/s !**

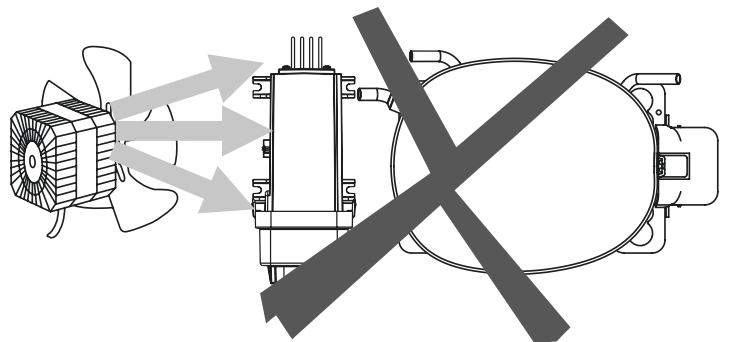
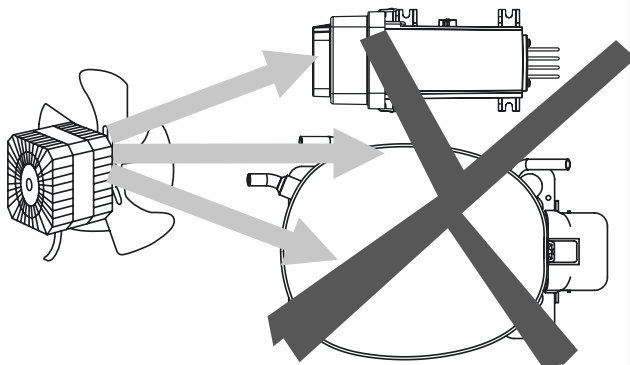
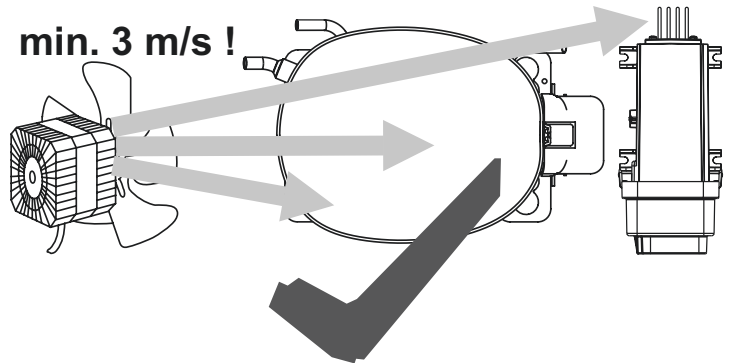

8938

<b>Airflow</b>	3 m/s
<b>Operating conditions</b>	+ 5 °C to 43 °C - humidity < 90 % rH non condensing
<b>Storage conditions</b>	-25 °C to 70 °C - humidity < 90 % rH non condensing
<b>Supply voltage</b>	100-240 V (± 10 %)
<b>Frequency</b>	50/60 Hz
<b>Input power, max.</b>	1000 W

Secop accepts no responsibility for possible errors in catalogs, brochures, and other printed material. Secop reserves the right to alter its products without notice. This also applies to products already on order provided that such alterations can be made without subsequent changes being necessary to specifications already agreed. All trademarks in this material are the property of the respective companies. Secop and the Secop logotype are trademarks of Secop GmbH. All rights reserved. [www.secop.com](http://www.secop.com)



# Instructions

## NLV Compressors

### 100-240V 50/60Hz

### 105N486x Series

### Controllers

**SECCP**

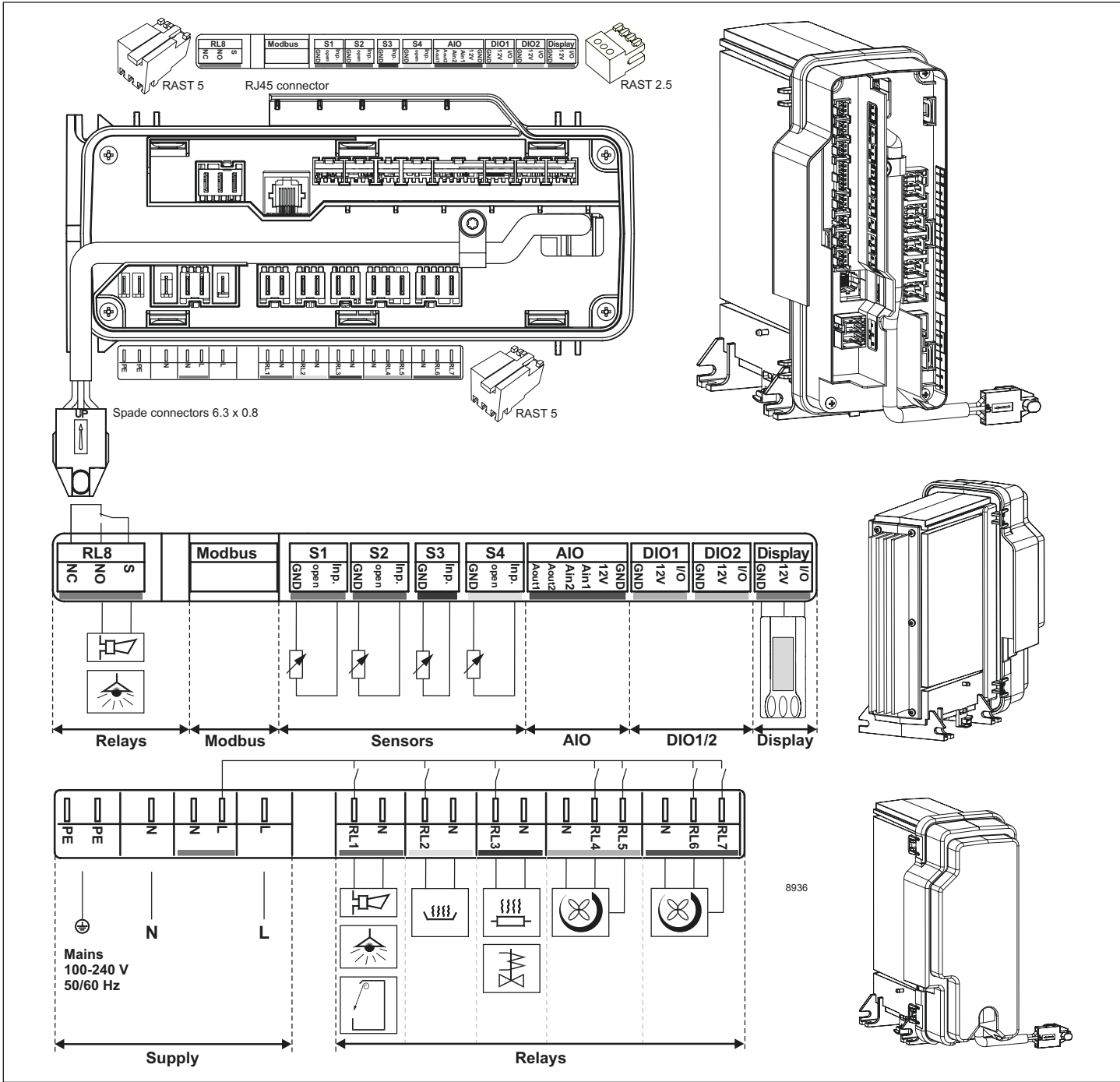

<b>Mains</b>	red	<b>S1</b>	red
<b>RL 1</b>	blue	<b>S2</b>	blue
<b>RL 2</b>	yellow	<b>S3</b>	black
<b>RL 3</b>	black	<b>S4</b>	yellow
<b>RL 4, 5</b>	grey	<b>AIO</b>	brown
<b>RL 6, 7</b>	brown	<b>DIO1</b>	grey
<b>RL 8</b>	green	<b>DIO2</b>	pink
		<b>Display</b>	green

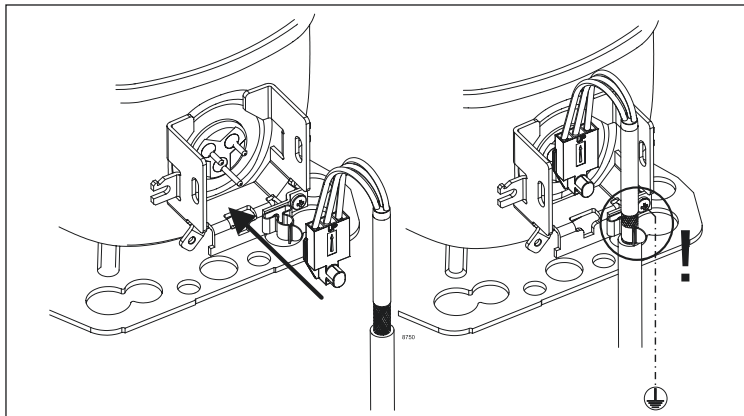

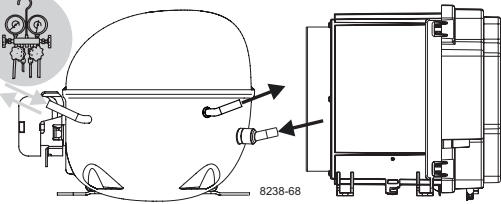

# Instructions

NLV Compressors  
100-240V 50/60Hz  
105N486x Series  
Controllers

# SECCP



## Service/Repair R290

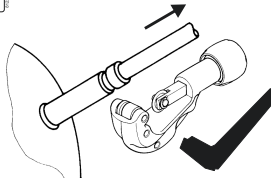
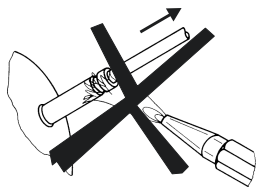

## Brazing on Suction Connectors (Direct Intake)

representative image

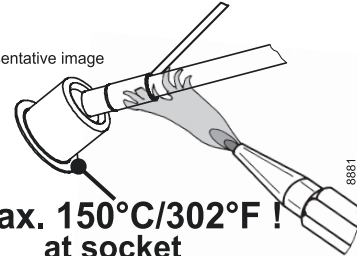

**! max. 150°C/302°F!  
at socket**

brazing solder: phosphor (LP7) or silver

Refer to Product Bulletin: **Brazing on Suction Connectors  
(Compressors with Direct Suction Intake)**

**min. 3 m/s!**

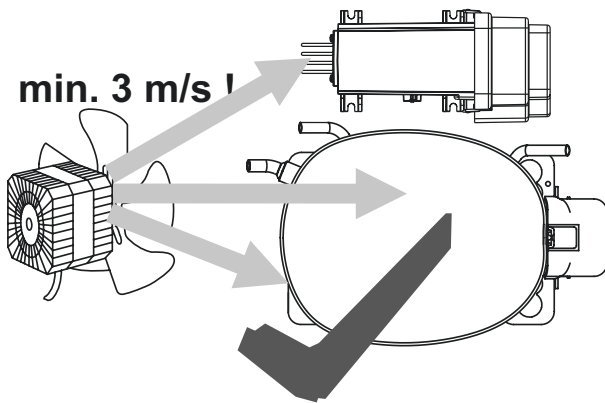

**min. 3 m/s!**

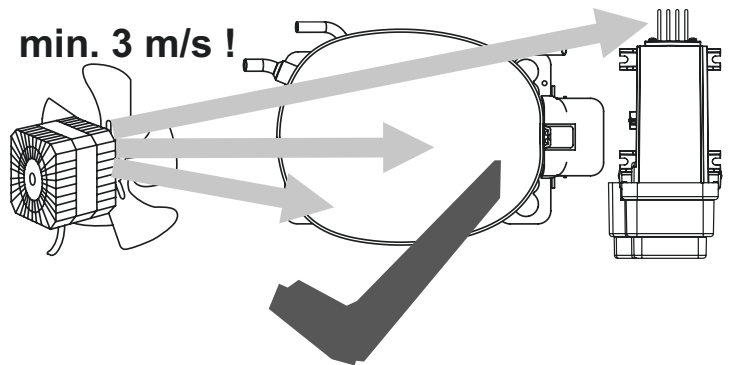

8939

<b>Airflow</b>	3 m/s
<b>Operating conditions</b>	+ 5 °C to 43 °C - humidity < 90 % rH non condensing
<b>Storage conditions</b>	-25 °C to 70 °C - humidity < 90 % rH non condensing
<b>Supply voltage</b>	100-240 V (± 10 %)
<b>Frequency</b>	50/60 Hz
<b>Input power, max.</b>	1000 W

Secop accepts no responsibility for possible errors in catalogs, brochures, and other printed material. Secop reserves the right to alter its products without notice. This also applies to products already on order provided that such alterations can be made without subsequent changes being necessary to specifications already agreed. All trademarks in this material are the property of the respective companies. Secop and the Secop logotype are trademarks of Secop GmbH. All rights reserved. [www.secop.com](http://www.secop.com)