

Single Pack SC15/15DL 220-240V 50Hz CSCR

Single pack code number: **195B3087**

Position	Title	Code	Amount
1	Compressor SC15/15DL	104L4093	1
2	SC starting device (550mm)	117-7029	2
3	Cover	103N2009	2
4	Cord relief	103N1004	2
5	Bolt joint for one compressor M6 ø16mm	118-1917	2

Secop GmbH • Lise-Meitner-Straße 29 • 24941 Flensburg, Germany • Tel: +49 461 4941 0 • www.secop.com

Secop accepts no responsibility for possible errors in catalogs, brochures, and other printed material. Secop reserves the right to alter its products without notice. This also applies to products already on order provided that such alterations can be made without subsequent changes being necessary to specifications already agreed. All trademarks in this material are the property of the respective companies. Secop and the Secop logotype are trademarks of Secop GmbH. All rights reserved.

Model

Designation	SC15/15DL	220-240V/50Hz 1~	Sales code:	104L4093
-------------	------------------	------------------	-------------	-----------------

Compressor design

Oil type	Polyolester	Refrigerant(s)	R404A, R507, R407C
Oil viscosity	32cST	Displacement	30,56cm ³ / 1,86cu.in
Oil quantity	1233cm ³ / 41,7fl.oz	Compressors on pallet	18
Refr. charge - tech. limit	2200g / 77,6oz		
Free gas volume comp.	2920cm ³ / 98,7fl.oz		
Weight	27,8kg / 61,3lbs		
Motor protection	1# internal		
Winding resistance main	3,5Ω (at 25°C)		
Winding resistance aux	13Ω (at 25°C)		
Max. winding temp.	125°C / 257°F		
Max. discharge temp.	135°C / 275°F		



General - Configurations with SC15/15DL

	Conf. 1	Conf. 2
Motorconfiguration	CSCR	CSCR
Power supply (nominal)	220-240V/50Hz	220-240V/50Hz
Number of phases	1	1
Voltage range	198-254V	198-254V
Approvals	CCC, VDE	CCC, VDE
Starting torque	HST	HST
Note	- / -	

Applications with SC15/15DL

	Conf. 1	Conf. 2
Refrigerant	R404A	R407C
Application	HBP	HBP
System cooling	fan 3m/s	fan 3m/s
Hot gas defrost	OK	OK
Long interval pull down	OK	OK

Electrical data - Configurations with SC15/15DL

	Conf. 1	Conf. 2
Starting device type	relay	relay
Run capacitor	10μF	10μF
Start capacitor	80μF	80μF
LRA (locked rotor amps / 4s)	2x 22A	2x 22A
RLA (rated load amps / 1s)	2x 3,9A	2x 3,9A
Cut in current	2x 22A	2x 22A

Model

Designation

SC15/15DL

220-240V/50Hz 1~

Sales code:

104L4093

Compressor dimensions

Housing	A Height	259mm / 10,2in
	B Height	254mm / 10in
	B1	193mm / 7,6in
	B2	110mm / 4,33in

Connectors		Suction	Discharge	Process
		C	E	D
Diameter	[mm]	øi 15,21-15,37	øi 6,11-6,29	øi 6,11-6,29
(i:inside, o:outside)	[in]	øi 0,6-0,61	øi 0,24-0,25	øi 0,24-0,25
Material		steel	copper	copper
Horizontal angle	±2°	0°	37°	37°
Vertical angle	±2°	0°	0°	0°
Position l/h/w	[mm]	0/0/0	0/0/0	0/0/0
	[in]	0/0/0	0/0/0	0/0/0
Straight tube l.	[mm]	10	12	12
	[in]	0,4	0,5	0,5

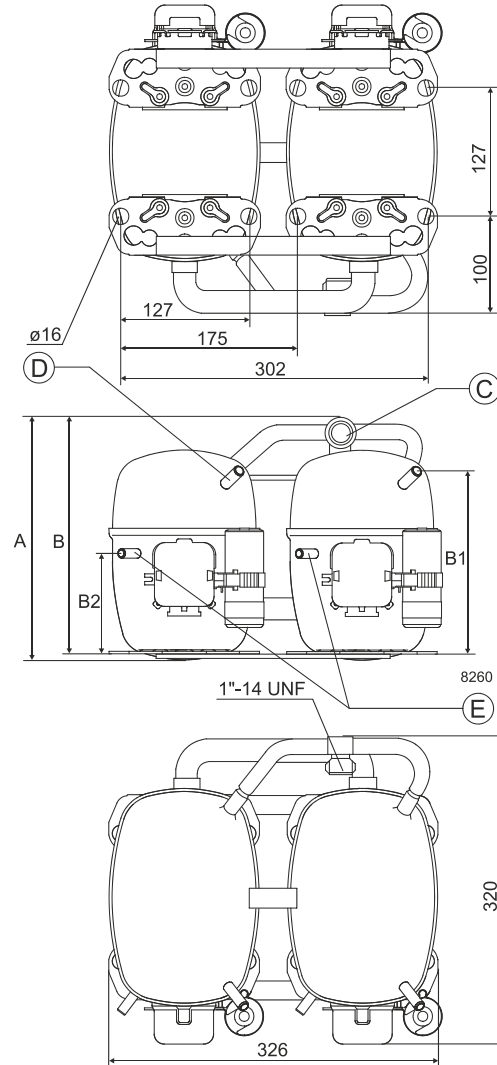

Compressor fixation

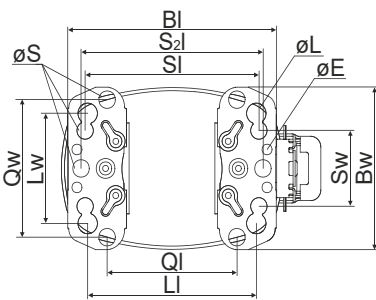

Baseplate	[mm]	[inch]
BI	204	8.03
Bw	150	5.9
øE	ø 9.7	ø 0.38
Large holes		
LI	165	6.5
Lw	101.6	4
øL	ø 19	ø 0.75
Small holes		
SI	170	6.7
Sw	70	2.76
øS	ø 16	ø 0.63
QI	127	5
Qw	127	5

Mounting accessories

	one comp.	multi pack
Bolt joint M6 ø16mm	118-1917	118-1918
Bolt joint ø1/4" ø16mm	118-1946	
Bolt joint ø1/4" ø19mm	118-1949	
Snap-on ø7,3 ø16mm	118-1947	118-1919

Bolt joint

Snap-on

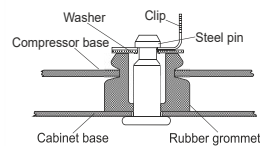
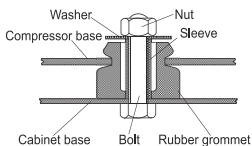

Application notes

Provision for PE Grounding is located at the PE Stamp on the compressor

Twin should be used with a time-delay relay

Model

Designation	SC15/15DL	220-240V/50Hz	Conf. 1	Sales code:	104L4093
-------------	------------------	----------------------	----------------	-------------	-----------------

Configuration

Motorconfiguration	CSCR
Power supply (nominal)	220-240V/50Hz 1~
Refrigerant	R404A
Application	HBP
Voltage range	198-254V
Starting torque	HST
Approvals	CCC, VDE,

Ambient/ machine room temperatures minimum /maximum

Ambient temperature range:	10 - 38°C / 50 - 101°F
Machine room temperature range:	10 - 43°C / 50 - 110°F
Compressor cooling:	fan 3m/s

Operation Limits

Electrical accessories / wiring diagram

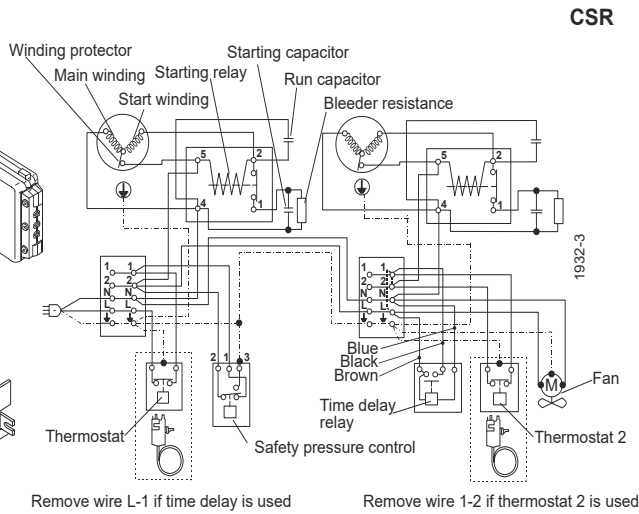
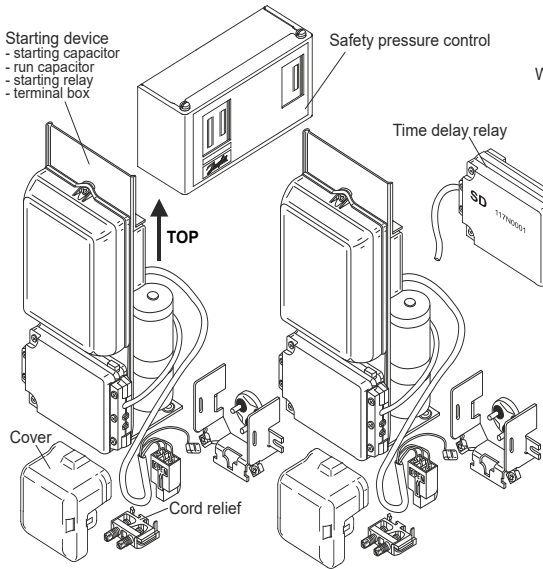

Operation pressure range

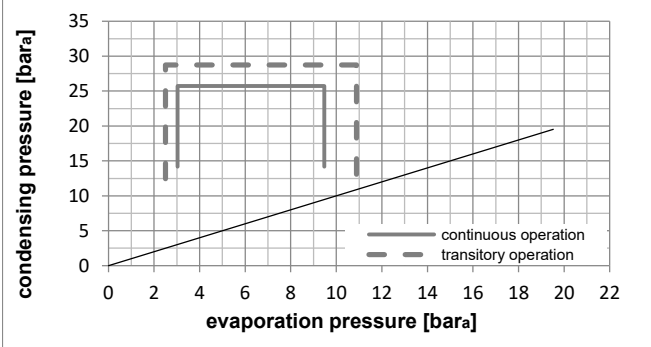
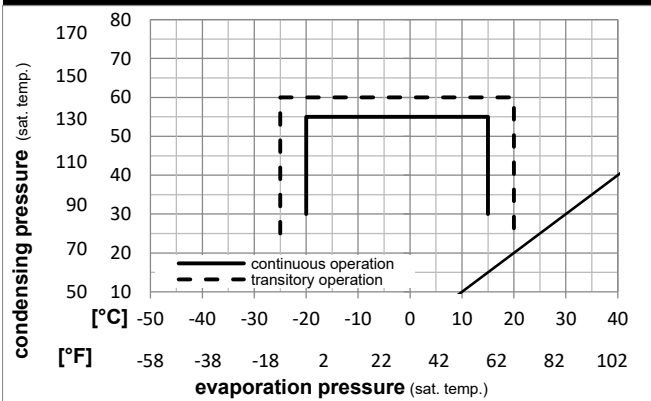

Components

a3	SC starter kit (550mm)	117-7029
b	plastic cover	103N2009
d	cord relief	103N1004
.	Half Twin compressor	104L2862
.	Check valve (to be used with time-delay relay)	020-1014
.	Service valve 16mm	118-7351
.	Solder connector (alternative) 16 mm	118-7405
.	Seal ring for service valve and solder conn.	118-3638

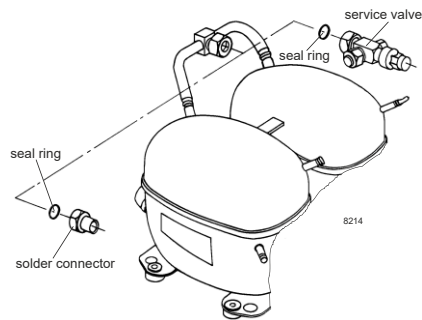

Model

Designation **SC15/15DL** **220-240V/50Hz** Conf. 1 Sales code: **104L4093**

Optimization + standard conditions

R404A, 220V/50Hz, CSCR, fan 3m/s, CCC, VDE

		Evaporating pressure (saturation temperature)				Condensing pressure (saturation temperature)			Return gas temp.			Liquid temp.		Cooling capacity			COP	EER	Power consumption			ASHRAE HBP
		pe	pc	RGT	Tliq	[W]	[Btu/h]	[kcal/h]	[W/W]	[Btu/W _h]	[kcal/W _h]	P1	I	Ref. mass flow				ASHRAE HBP				
[°C]	[°F]											[W]	[A]	[kg/h]								
7,2	45	54	130	35	95	46	115	4530,7	15473	3899,2	2,25	7,67	1,93	2017,0	10,33	128,83				ASHRAE HBP		
5	41	55	131	32	90	55	131	3554,3	12139	3058,9	1,79	6,10	1,54	1989,6	10,19	118,37				cecomaf HBP		
5	41	50	122	20	68	50	122	3695,3	12620	3180,2	2,00	6,82	1,72	1850,1	9,55	126,02				EN12900 HBP		
-7	20	54	130	35	95	46	115	2625,7	8967	2259,7	1,56	5,33	1,34	1682,3	8,69	72,24				ASHRAE MBP		
-10	14	55	131	32	90	55	131	1939,8	6625	1669,4	1,22	4,16	1,05	1590,6	8,24	62,10				cecomaf MBP		
-10	14	45	113	20	68	45	113	2274,9	7769	1957,8	1,57	5,38	1,35	1444,9	7,58	68,52				EN12900 MBP		

Performance tables

R404A, 220V/50Hz, CSCR, fan 3m/s, CCC, VDE

	pe		Cooling capacity			COP	EER	P1			I	m
	[°C]	[°F]	[W]	[Btu/h]	[kcal/h]	[W/W]	[Btu/W _h]	[kcal/W _h]	[W]	[A]	[kg/h]	
[°C / °F]	-20	-4	1517,5	5183	1306,0	1,29	4,40	1,11	1178,1	6,19	41,17	
cond. pressure	-15	5	1928,4	6586	1659,6	1,46	4,99	1,26	1318,8	6,93	52,68	
pc= 45/113	-10	14	2414,4	8246	2077,8	1,67	5,71	1,44	1444,9	7,58	66,49	
return gas temp.	-5	23	2985,2	10195	2569,1	1,92	6,55	1,65	1555,9	8,14	82,99	
RGT= 32/90	0	32	3650,6	12468	3141,8	2,21	7,55	1,90	1651,2	8,61	102,63	
liquid temp	5	41	4420,3	15096	3804,2	2,55	8,72	2,20	1730,3	9,00	125,92	
Tliq= 45/113	15	59	6311,3	21554	5431,5	3,43	11,73	2,96	1837,4	9,50	186,11	
[°C / °F]	-20	-4	1152,9	3938	992,2	0,93	3,18	0,80	1237,7	6,50	36,28	
cond. pressure	-15	5	1523,9	5204	1311,5	1,07	3,66	0,92	1422,5	7,42	48,33	
pc= 55/131	-10	14	1939,8	6625	1669,4	1,22	4,16	1,05	1590,6	8,24	62,10	
return gas temp	-5	23	2410,3	8232	2074,4	1,38	4,73	1,19	1741,6	8,98	78,02	
RGT= 32/90	0	32	2945,3	10059	2534,7	1,57	5,37	1,35	1874,8	9,63	96,58	
liquid temp	5	41	3554,3	12139	3058,9	1,79	6,10	1,54	1989,6	10,19	118,37	
Tliq= 55/131	15	59	5033,4	17190	4331,8	2,33	7,95	2,00	2162,2	11,04	174,55	

Model

Designation	SC15/15DL	220-240V/50Hz	Conf. 2	Sales code:	104L4093
-------------	------------------	----------------------	----------------	-------------	-----------------

Configuration

Motorconfiguration	CSCR
Power supply (nominal)	220-240V/50Hz 1~
Refrigerant	R407C
Application	HBP
Voltage range	198-254V
Starting torque	HST
Approvals	CCC, VDE,

Ambient/ machine room temperatures minimum /maximum

Ambient temperature range:	10 - 38°C / 50 - 101°F
Machine room temperature range:	10 - 43°C / 50 - 110°F
Compressor cooling:	fan 3m/s

Operation Limits

Electrical accessories / wiring diagram

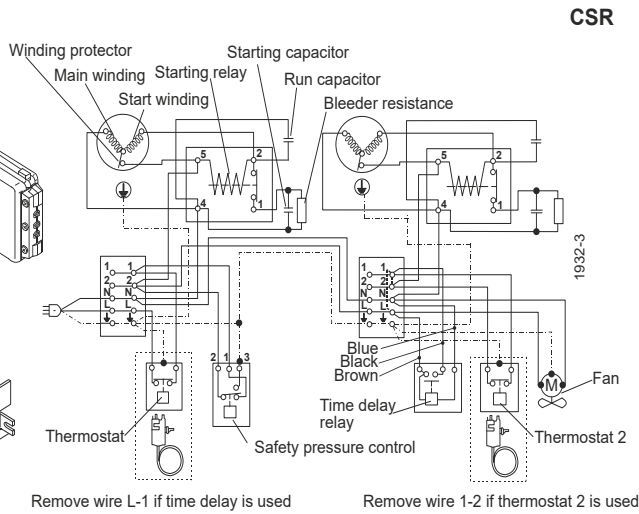
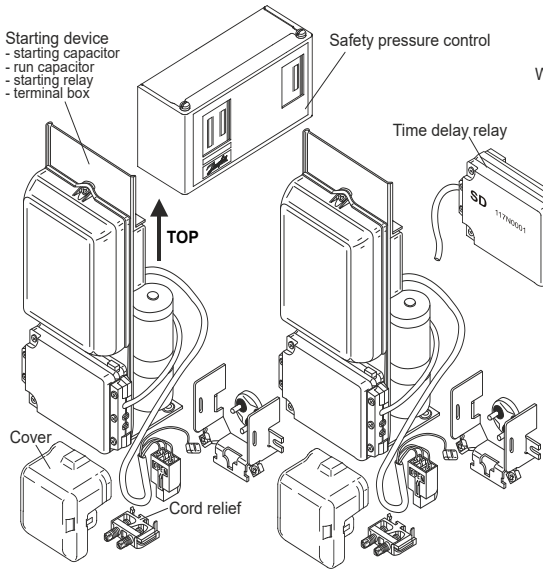

Operation pressure range

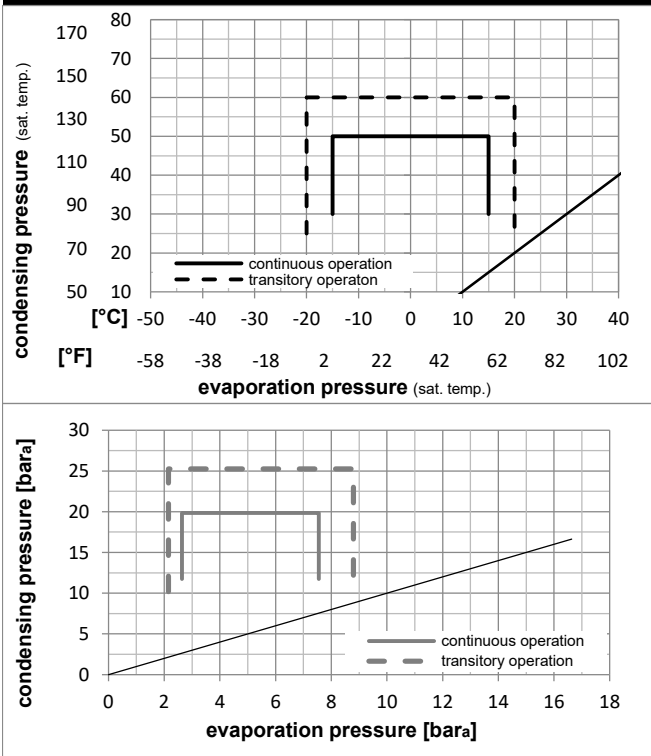

Components

a3	SC starter kit (550mm)	117-7029
b	plastic cover	103N2009
d	cord relief	103N1004
.	Half Twin compressor	104L2862
.	Check valve (to be used with time-delay relay)	020-1014
.	Service valve 16mm	118-7351
.	Solder connector (alternative) 16 mm	118-7405
.	Seal ring for service valve and solder conn.	118-3638

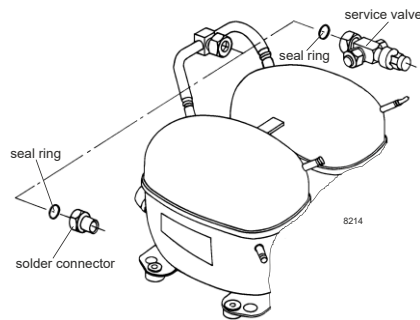

Model

Designation	SC15/15DL	220-240V/50Hz	Conf. 2	Sales code:	104L4093
-------------	------------------	----------------------	----------------	-------------	-----------------

Optimization + standard conditions

R407C, 220V/50Hz, CSCR, fan 3m/s, CCC, VDE

	Evaporating pressure (saturation temperature)				Cooling capacity			COP	EER	P1	Power consumption		Ref. mass flow m	
	pe	pc	RGT	Tliq	[W]	[Btu/h]	[kcal/h]				[W]	[A]		
[°C]	7,2	54	35	46	4139,0	14135	3562,0	2,59	8,85	2,23	1596,7	7,97	88,46	ASHRAE HBP
[°F]	45	130	95	115										
[°C]	5	55	32	55	3373,3	11521	2903,1	2,16	7,38	1,86	1561,0	7,81	80,42	cecomaf HBP
[°F]	41	131	90	131										
[°C]	5	50	20	50	3531,4	12061	3039,2	2,34	7,99	2,01	1509,2	7,59	85,59	EN12900 HBP
[°F]	41	122	68	122										
[°C]	-7	54	35	46	2211,6	7553	1903,3	1,70	5,80	1,46	1301,9	6,66	46,18	ASHRAE MBP
[°F]	20	130	95	115										
[°C]	-10	55	32	55	1665,3	5687	1433,2	1,37	4,66	1,17	1219,8	6,30	38,66	cecomaf MBP
[°F]	14	131	90	131										
[°C]	-10	45	20	45	1952,9	6669	1680,7	1,66	5,65	1,42	1179,8	6,17	43,47	EN12900 MBP
[°F]	14	113	68	113										

Performance tables

R407C, 220V/50Hz, CSCR, fan 3m/s, CCC, VDE

	pe		Cooling capacity			COP	EER		P1	I	m
	[°C]	[°F]	[W]	[Btu/h]	[kcal/h]		[Btu/Wh]	[kcal/Wh]			
[°C / °F]	-15	5	1553,6	5306	1337,1	1,45	4,96	1,25	1068,7	5,68	32,27
cond. pressure	-10	14	2022,4	6907	1740,5	1,71	5,85	1,48	1179,8	6,17	42,25
pc= 45/113	-5	23	2586,4	8833	2225,9	2,02	6,90	1,74	1280,9	6,60	54,39
return gas temp.	0	32	3257,2	11124	2803,2	2,37	8,11	2,04	1371,7	6,99	69,04
RGT= 32/90	5	41	4046,5	13820	3482,5	2,79	9,52	2,40	1451,9	7,34	86,58
liquid temp	10	50	4966,0	16960	4273,8	3,26	11,15	2,81	1521,3	7,63	107,43
Tliq= 45/113	15	59	6027,1	20584	5187,0	3,82	13,03	3,28	1579,5	7,88	132,11
[°C / °F]	-15	5	1244,6	4251	1071,1	1,15	3,92	0,99	1084,0	5,70	28,71
cond. pressure	-10	14	1665,3	5687	1433,2	1,37	4,66	1,17	1219,8	6,30	38,66
pc= 55/131	-5	23	2152,5	7351	1852,5	1,60	5,47	1,38	1344,7	6,85	50,34
return gas temp	0	32	2718,0	9283	2339,2	1,86	6,36	1,60	1458,5	7,35	64,13
RGT= 32/90	5	41	3373,3	11521	2903,1	2,16	7,38	1,86	1561,0	7,81	80,42
liquid temp	10	50	4130,1	14105	3554,4	2,50	8,54	2,15	1651,7	8,22	99,69
Tliq= 55/131	15	59	4999,9	17076	4303,0	2,89	9,87	2,49	1730,4	8,58	122,47

SC Twin Compressors

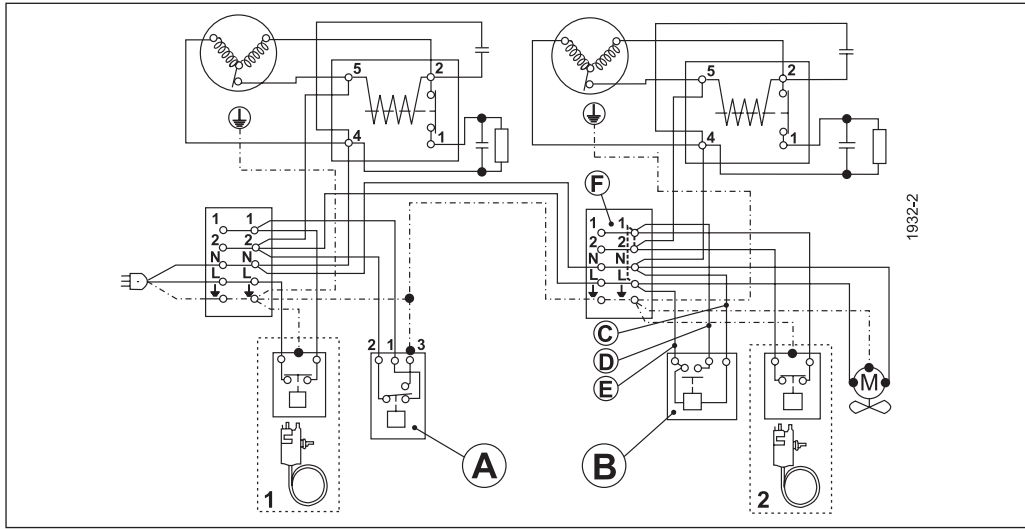
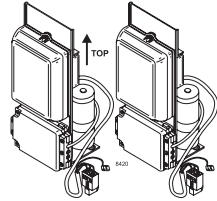
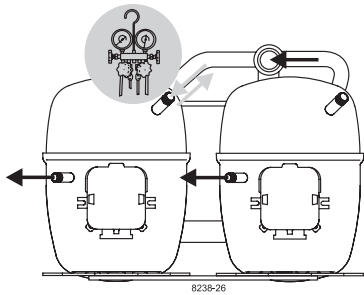

	A	B	C	D	E	F	
ENGLISH	Safety pressure control	Time delay relay	Blue	Black	Brown	Remove wire L-1 if time delay is used	Remove wire 1-2 if thermostat 2 is used
中文	安全压力控制	延时继电器	蓝	黑	棕	若延时继电器使用，线L-1不使用	若温控器2使用，线1-2不使用
Русский	Предохранительное реле давления	Реле задержки времени	Синий	Чёрный	Коричневый	Отсоедините провод L-1, если используется реле задержки времени	Отсоедините провод 1-2, если используется термостат 2
DEUTSCH	Sicherheitsdruckschalter	Zeitrelais (verzögernd)	Blau	Schwarz	Braun	Bei Benutzung der Anlaßverzögerung Brücke L-1 entfernen	Bei Benutzung von Thermostat 2 Brücke 1-2 entfernen
FRANÇAIS	Pressostat	Relais de temporisation	Bleu	Noir	Marron	Supprimer la connection L-1 si le relais de temporisation est utilisé	Supprimer la connection 1-2 si thermostat 2 est utilisé
ESPAÑOL	Presostato de seguridad	Relé de retardo	Azul	Negro	Marrón	Quitar cable L-1, si se utiliza un relé de retardo	Quitar cable 1-2, si se utiliza el termostato 2
ITALIANO	Pressostato	Relè di ritardo avviam.	Blu	Nero	Marrone	Eliminare il cavo L-1 se è utilizzato il ritardatore	Eliminare il cavo 1-2 se è utilizzato il termostato 2
NEDERLANDS	Pressostaat	Tijdvertragingrelais	Blauw	Zwart	Bruin	Verwijder draad L-1 indien tijdvertraging wordt toegepast	Verwijder draad 1-2 indien thermostaat wordt toegepast
DANSK	Sikkerhedspressostat	Tidsforsinkelsesrelæ	Blå	Sort	Brun	Ved tidsforsinkelse fjernes ledning L-1	Ved termostat 2 fjernes ledning 1-2
SVENSKA	Säkerhetspressostat	Tidsfördröjningsrelä	Blå	Svart	Brun	Vid anslutning av tidsfördröjningsrelä avlägsnas bygling L-1	Vid anslutning av termostat 2 avlägsnas bygling 1-2

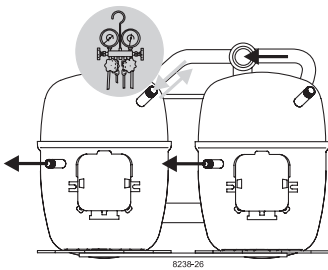

SC Twin Compressors

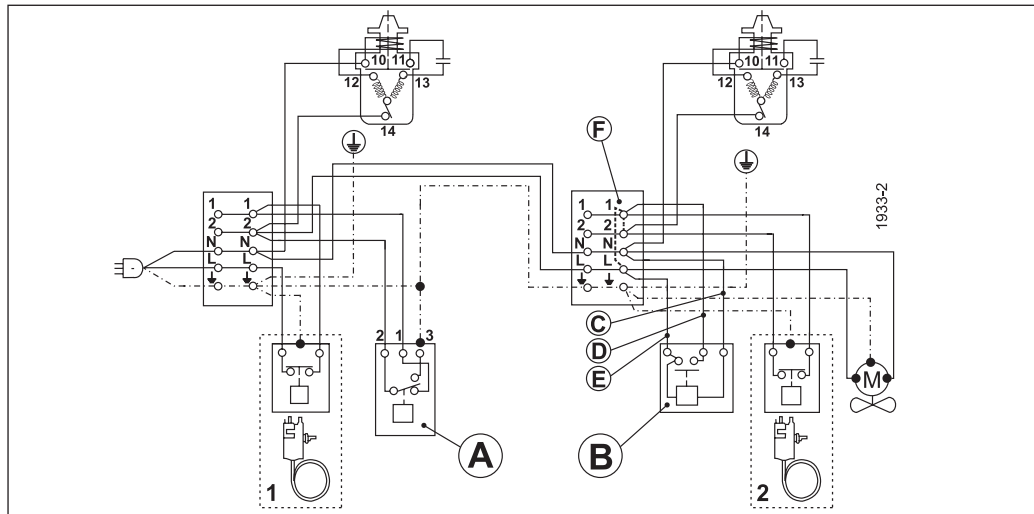
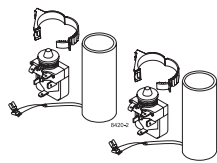

	A	B	C	D	E	F	
ENGLISH	Safety pressure control	Time delay relay	Blue	Black	Brown	Remove wire L-1 if time delay is used	Remove wire 1-2 if thermostat 2 is used
中文	安全压力控制	延时继电器	蓝	黑	棕	若延时继电器使用, 线L-1不使用	若温控器2使用, 线1-2不使用
Русский	Предохранительное реле давления	Реле задержки времени	Синий	Чёрный	Коричневый	Отсоедините провод L-1, если используется реле задержки времени	Отсоедините провод 1-2, если используется термостат 2
DEUTSCH	Sicherheitsdruckschalter	Zeitrelais (verzögernd)	Blau	Schwarz	Braun	Bei Benutzung der Anlaufverzögerung Brücke L-1 entfernen	Bei Benutzung von Thermostat 2 Brücke 1-2 entfernen
FRANÇAIS	Pressostat	Relais de temporisation	Bleu	Noir	Marron	Supprimer la connection L-1 si le relais de temporisation est utilisé	Supprimer la connection 1-2 si thermostat 2 est utilisé
ESPAÑOL	Presostato de seguridad	Relé de retardo	Azul	Negro	Marrón	Quitar cable L-1, si se utiliza un relé de retardo	Quitar cable 1-2, si se utiliza el termostato 2
ITALIANO	Pressostato	Relè di ritardo avviam.	Blu	Nero	Marrone	Eliminare il cavo L-1 se è utilizzato il ritardatore	Eliminare il cavo 1-2 se è utilizzato il termostato 2
NEDERLANDS	Pressostaat	Tijdvertraging-relais	Blauw	Zwart	Bruin	Verwijder draad L-1 indien tijdvertraging wordt toegepast	Verwijder draad 1-2 indien thermostaat wordt toegepast
DANSK	Sikkerhedspressostat	Tidsforsinkel-sesrelæ	Blå	Sort	Brun	Ved tidsforsinkelse fjernes ledning L-1	Ved termostat 2 fjernes ledning 1-2
SVENSKA	Säkerhetspressostat	Tidsfördröjningsrelä	Blå	Svart	Brun	Vid anslutning av tidsfördröjningsrelä avlägsnas bygling L-1	Vid anslutning av termostat 2 avlägsnas bygling 1-2

Secop accepts no responsibility for possible errors in catalogs, brochures, and other printed material. Secop reserves the right to alter its products without notice. This also applies to products already on order provided that such alterations can be made without subsequent changes being necessary to specifications already agreed. All trademarks in this material are the property of the respective companies. Secop and the Secop logotype are trademarks of Secop GmbH. All rights reserved. www.secop.com