

Single Pack HXK13AT 200-240V 50Hz RSCR

Single pack code number: **195B4621**

Position	Title	Code	Amount
1	Compressor HXK13AT	16507700	1
2	Clip	10633900	4
3	Steel pin	10634100	4
4	Washer	10634300	4
5	Screw for cable clamp	10636000	1
6	Screw for cable clamp	10636200	1
7	Cover	10636401	1
8	Earth screw	10641201	1
9	Rubber grommet 16mm	11322600	4
10	Run capacitor (4 μ F 400V, 6.3mm)	15186801	1
11	Terminal board 6.3mm	16425700	1

Secop GmbH • Lise-Meitner-Straße 29 • 24941 Flensburg, Germany • Tel: +49 461 4941 0 • www.secop.com

Secop accepts no responsibility for possible errors in catalogs, brochures, and other printed material. Secop reserves the right to alter its products without notice. This also applies to products already on order provided that such alterations can be made without subsequent changes being necessary to specifications already agreed. All trademarks in this material are the property of the respective companies. Secop and the Secop logotype are trademarks of Secop GmbH. All rights reserved.

Model

Designation	HXK13AT	200-240V/50Hz 1~	Sales code:	16507700
-------------	----------------	------------------	-------------	-----------------

Compressor design

Oil type	Mineral	Refrigerant(s)	R600a
Oil viscosity	5cST	Displacement	12,5cm ³ / 0,76cu.in
Oil quantity	162cm ³ / 5,5fl.oz	Compressors on pallet	100
Refr. charge - tech. limit	150g / 5,3oz		
Free gas volume comp.	1560cm ³ / 52,7fl.oz		
Weight	8,6kg / 19lbs		
Motor protection	external		
Winding resistance main	12,4Ω (at 25°C)		
Winding resistance aux	15,3Ω (at 25°C)		
Max. winding temp.	130°C / 266°F		
Max. discharge temp.	130°C / 266°F		



General - Configurations with HXK13AT

	Conf. 1
Motorconfiguration	RSCR
Power supply (nominal)	200-240V/50Hz
Number of phases	1
Voltage range	180-264V
Approvals	VDE
Starting torque	LST
Note	Various options of connectors are possible - please contact SECOP-Sales.

Applications with HXK13AT

	Conf. 1
Refrigerant	R600a
Application	LBP
System cooling	static
Hot gas defrost	-/-
Long interval pull down	-/-

Electrical data - Configurations with HXK13AT

	Conf. 1
Starting device type	PTC
Run capacitor	4μF
Start capacitor	-/-
LRA (locked rotor amps / 4s/ U(N))	8,2A
RLA (rated load amps / 1s/ U(N))	
Cut in current (U(N))	16,4A

Model

Designation	HXK13AT	200-240V/50Hz 1~	Sales code:	16507700
-------------	----------------	------------------	-------------	-----------------

Compressor dimensions

Housing	A Height	174mm / 6,85in
	B Height	167mm / 6,57in
	C Length shell	194mm / 7,64in
	D Length w. cover	238mm / 9,37in
	E Width	151mm / 5,94in

Connectors		Suction	Discharge	Process
		X	Y	Z
Diameter	[mm]	øi 6,1-6,2	øi 5,1-5,2	øo 5,92-6,08
	(i:inside, o:outside) [in]	øi 0,24-0,24	øi 0,2-0,2	øo 0,23-0,24
Material		copper	copper	copper
Horizontal angle	±2°	45°	13°	0°
Vertical angle	±2°	30°	40°	145°
Position l/h/w	[mm]	120/72/62	112/106/62	-140/136/70
	[in]	4,7/2,8/2,4	4,4/4,2/2,4	-5,5/5,4/2,8
Straight tube l.	[mm]	14	14	75
	[in]	0,5	0,5	3

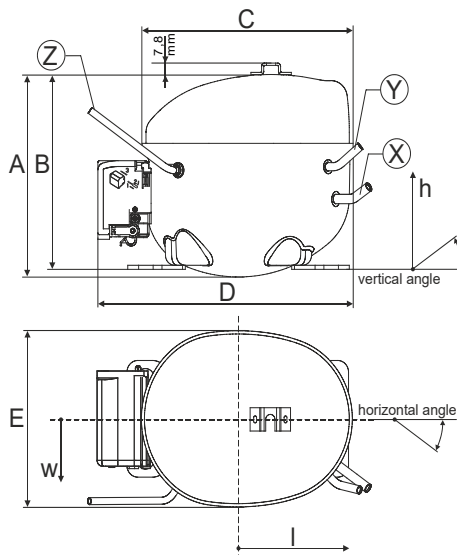

Compressor fixation

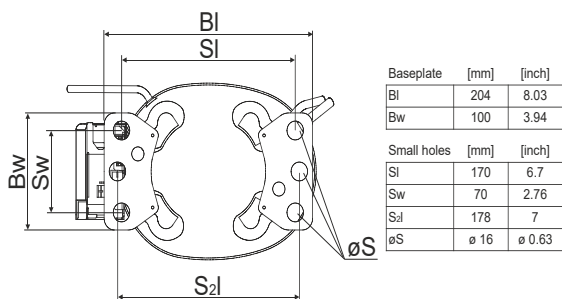

Bolt joint

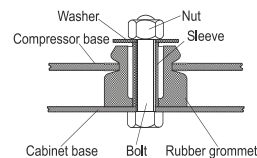

Snap-on

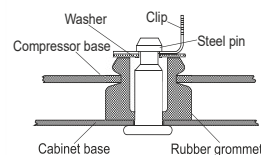

Mounting accessories

	order code
'4ZN' with rubber grommet	772N
'4ZN' with rubber grommet and sleeve for M6	768N
Bolt joint kit	4ZN + 118-1917 (18)
'4ZN' with Snap on kit	776N

Application notes

- Provision for PE Grounding is located at the PE Stamp on the compressor Housing with dip-tray fixture (omega bracket).
- Various options of connectors are possible - please contact SECOP-Sales.

Model

Designation	HXK13AT	200-240V/50Hz	Conf. 1	Sales code:	16507700
-------------	----------------	----------------------	---------	-------------	-----------------

Configuration

Motorconfiguration	RSCR
Power supply (nominal)	200-240V/50Hz 1~
Refrigerant	R600a
Application	LBP
Voltage range	180-264V
Starting torque	LST
Approvals	VDE

Electrical accessories / wiring diagram

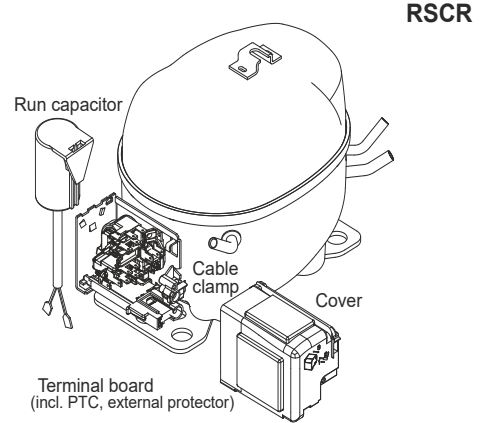

Ambient/ machine room temperatures minimum /maximum

Ambient temperature range:	10 - 43°C / 50 - 110°F
Machine room temperature range:	10 - 48°C / 50 - 119°F
Compressor cooling:	static

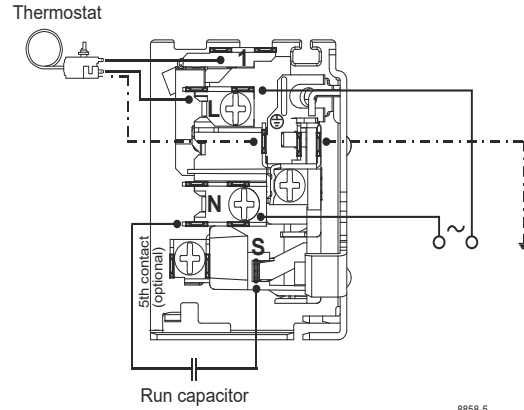

Operation pressure range

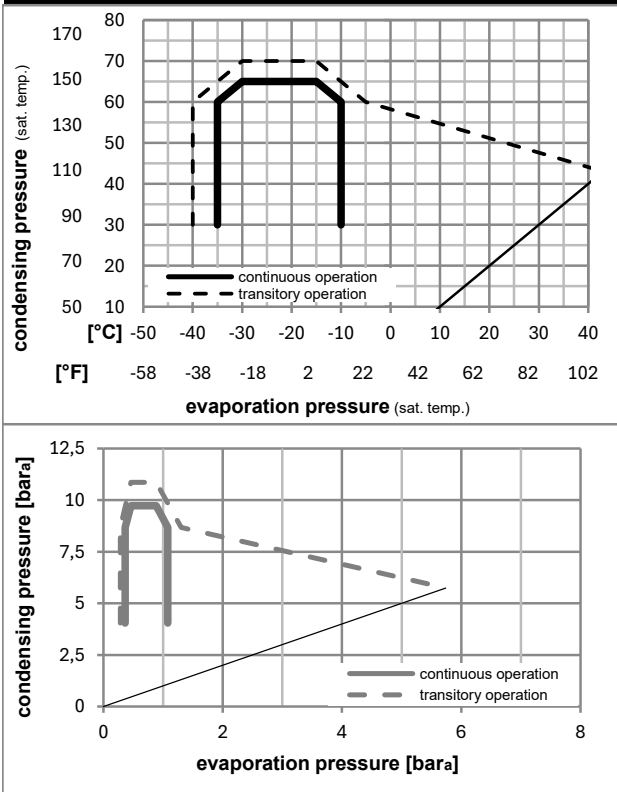

Components

. terminal board (PTC, 4.8mm)	16425900
. run capacitor (4μF, 4.8mm)	10693001
b cover terminal board	10636401
. cable clamp	11341000
. screw - uni6954	10636000
. screw - uni6954	10636200

Alternative components

. terminal board (PTC, 6.3mm)	16425700
. run capacitor (4μF, 6.3mm)	15186801
. screw uni en iso 4757	10641201

Model

Designation **HXK13AT** **200-240V/50Hz** Conf. 1 Sales code: **16507700**

Optimization + standard conditions

R600a, 200V/50Hz, RSCR, static, VDE

Evaporating pressure (saturation temperature)				Condensing pressure (saturation temperature)			Power consumption				Current consumption		Ref. mass flow ṁ	
pe	pc	RGT	Tliq	Cooling capacity	COP	EER	P1	I						
[°C]	[°C]	[°C]	[°C]	[W]	[Btu/h]	[kcal/h]	[W/W]	[Btu/Wh]	[kcal/Wh]	[W]	[A]	[kg/h]		
-23	54	32	32	226,3	773	194,7	1,65	5,63	1,42	137,4	0,74	2,43	ASHRAE LBP	
-10	130	90	90											
-25	55	32	55	170,9	584	147,1	1,31	4,46	1,12	130,9	0,71	2,23	cecomaf LBP	
-13	131	90	131											
-35	40	20	40	117,1	400	100,8	1,42	4,86	1,22	82,3	0,46	1,43	EN12900 LBP	
-31	104	68	104											
-23	49	4,4	49	181,3	619	156,0	1,33	4,56	1,15	135,9	0,74	2,65	ARI540 LBP	
-10	120	40	120											
-23	41	32	32	234,8	802	202,0	1,76	6,03	1,52	133,0	0,72	2,52	AHAM LBP	
-10	105	90	90											
-35	45	32	45	113,1	386	97,4	1,31	4,48	1,13	86,3	0,48	1,34	opt	
-31	113	90	113											

Performance tables

R600a, 200V/50Hz, RSCR, static, VDE

	pe		Cooling capacity			COP	EER	P1	I	m	
	[°C]	[°F]	[W]	[Btu/h]	[kcal/h]	[W/W]	[Btu/Wh]	[kcal/Wh]	[W]	[A]	[kg/h]
[°C / °F]	-35	-31	113,1	386	97,4	1,31	4,48	1,13	86,3	0,48	1,34
cond. pressure	-30	-22	149,3	510	128,5	1,39	4,74	1,19	107,5	0,59	1,77
pc= 45/113	-25	-13	192,9	659	166,0	1,51	5,15	1,30	127,8	0,70	2,30
return gas temp.	-23	-10	209,6	716	180,3	1,56	5,32	1,34	134,5	0,73	2,50
RGT= 32/90	-20	-4	244,9	836	210,8	1,66	5,67	1,43	147,5	0,80	2,92
liquid temp	-15	5	306,6	1047	263,8	1,83	6,26	1,58	167,4	0,90	3,66
Tliq= 45/113	-10	14	378,8	1294	326,0	2,02	6,89	1,74	187,8	1,00	4,54
[°C / °F]	-35	-31	95,7	327	82,4	0,99	3,37	0,85	97,0	0,54	1,25
cond. pressure	-30	-22	130,4	445	112,2	1,15	3,94	0,99	113,0	0,62	1,70
pc= 55/131	-25	-13	170,9	584	147,1	1,31	4,46	1,12	130,9	0,71	2,23
return gas temp	-23	-10	186,2	636	160,3	1,35	4,62	1,16	137,6	0,75	2,43
RGT= 32/90	-20	-4	218,3	746	187,9	1,44	4,93	1,24	151,4	0,82	2,85
liquid temp	-15	5	273,8	935	235,6	1,57	5,35	1,35	174,9	0,94	3,58
Tliq= 55/131	-10	14	338,2	1155	291,1	1,68	5,72	1,44	201,9	1,07	4,44

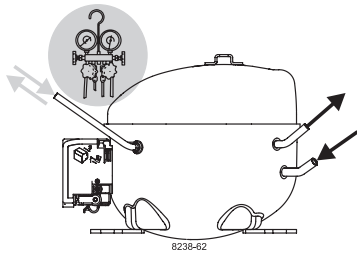

K-Series Compressors

GTK, HKK, HMK, HTK, HXK, HZK

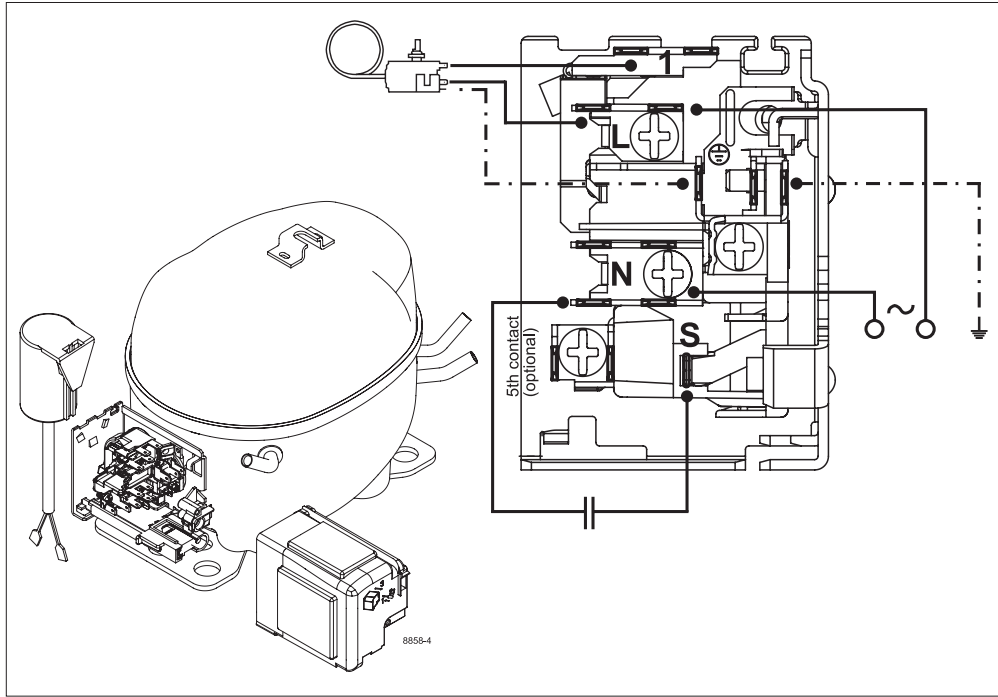

Service/Repair – R600a

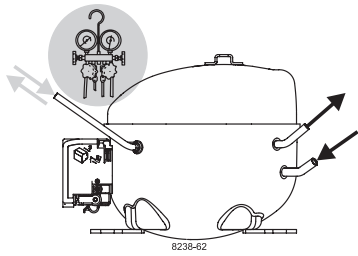

K-Series Compressors

GTK, HKK, HMK, HTK, HXK, HZK

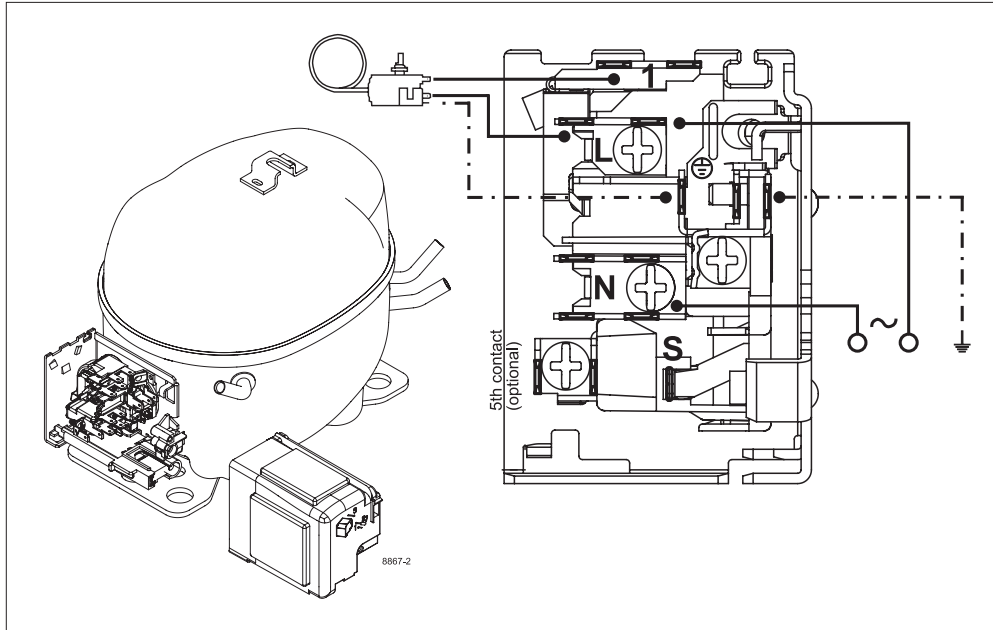

Service/Repair – R600a

Secop accepts no responsibility for possible errors in catalogs, brochures, and other printed material. Secop reserves the right to alter its products without notice. This also applies to products already on order provided that such alterations can be made without subsequential changes being necessary to specifications already agreed. All trademarks in this material are the property of the respective companies. Secop and the Secop logotype are trademarks of Secop GmbH. All rights reserved. www.secop.com