

## Single Pack SC12G 220-240V 50Hz / 208-230V 60Hz CSIR

Single pack code number: **195B4016**

Position	Title	Code	Amount
1	Compressor SC12G	104G8240	1
2	Starting relay	117U6003	1
3	Starting capacitor (80 $\mu$ F 220V, 6.3mm)	117U5017	1
4	Cord relief	103N1004	1
5	Cover	103N2009	1
6	Bolt joint for one compressor   M6   $\varnothing$ 16mm	118-1917	1

Secop GmbH • Lise-Meitner-Straße 29 • 24941 Flensburg, Germany • Tel: +49 461 4941 0 • [www.secop.com](http://www.secop.com)

Secop accepts no responsibility for possible errors in catalogs, brochures, and other printed material. Secop reserves the right to alter its products without notice. This also applies to products already on order provided that such alterations can be made without subsequent changes being necessary to specifications already agreed. All trademarks in this material are the property of the respective companies. Secop and the Secop logotype are trademarks of Secop GmbH. All rights reserved.

## Model

Designation	<b>SC12G</b>	220-240V/50Hz 1~ 208-230V/60Hz 1~	Sales code:	<b>104G8240</b>
-------------	--------------	-----------------------------------	-------------	-----------------

## Compressor design

Oil type	Polyolester	Refrigerant(s)	<b>R134a, R513A</b>
Oil viscosity	22cST	Displacement	12,87cm <sup>3</sup> / 0,79cu.in
Oil quantity	550cm <sup>3</sup> / 18,6fl.oz	Compressors on pallet	80
Refr. charge - tech. limit	1300g / 45,9oz		
Free gas volume comp.	1510cm <sup>3</sup> / 51,1fl.oz		
Weight	12,7kg / 28lbs		
Motor protection	1# internal		
Winding resistance main	6,9Ω (at 25°C)		
Winding resistance aux	11Ω (at 25°C)		
Max. winding temp.	125°C / 257°F		
Max. discharge temp.	130°C / 266°F		



## General - Configurations with SC12G

	<b>Conf. 1</b>	<b>Conf. 2</b>	<b>Conf. 3</b>	<b>Conf. 4</b>	<b>Conf. 5</b>
Motorconfiguration	CSIR	CSIR	CSIR	CSIR	RSIR
Power supply (nominal)	220-240V/50Hz	208-230V/60Hz	220-240V/50Hz	208-230V/60Hz	220-240V/50Hz
Number of phases	1	1	1	1	1
Voltage range	187-254V	198-254V	187-254V	187-253V	187-254V
Approvals	VDE, UL, CCC, EAC, KC	VDE, UL, CCC, EAC, KC	VDE, UL, CCC	VDE, UL, CCC	VDE, UL, CCC, EAC, KC
Starting torque	HST	HST	HST	HST	LST
Note	- / -				

## Applications with SC12G

	<b>Conf. 1</b>	<b>Conf. 2</b>	<b>Conf. 3</b>	<b>Conf. 4</b>	<b>Conf. 5</b>
Refrigerant	R134a	R134a	R513A	R513A	R134a
Application	LBP+MBP+HBP	LBP	LBP+MBP+HBP	LBP	LBP+MBP+HBP
System cooling	fan 3m/s	fan 3m/s	fan 3m/s	fan 3m/s	fan 3m/s
Hot gas defrost	OK	OK	OK	OK	OK
Long interval pull down	OK	OK	OK	OK	OK

## Electrical data - Configurations with SC12G

	<b>Conf. 1</b>	<b>Conf. 2</b>	<b>Conf. 3</b>	<b>Conf. 4</b>	<b>Conf. 5</b>
Starting device type	relay	relay	relay	relay	PTC
Run capacitor	- / -	- / -	- / -	- / -	- / -
Start capacitor	80μF	80μF	80μF	80μF	- / -
LRA (locked rotor amps / 4s)	13A	13A	13A	13A	12,6A
RLA (rated load amps / 1s)	2,5A	2,5A	2,5A	2,5A	2,5A
Cut in current	17A	17A	17A	17A	12,6A

## Model

Designation

**SC12G**

220-240V/50Hz 1~ 208-230V/60Hz 1~

Sales code:

**104G8240**

## Compressor dimensions

<b>Housing</b>	A Height	209mm / 8,23in
	B Height	203mm / 7,99in
	C Length shell	218mm / 8,58in
	D Length w. cover	255mm / 10,04in
	E Width	151mm / 5,94in

Connectors	Suction X	Discharge Y	Process Z
Diameter [mm]	øi 8,11-8,29	øi 6,11-6,29	øi 6,11-6,29
(i:inside, o:outside) [in]	øi 0,32-0,33	øi 0,24-0,25	øi 0,24-0,25
Material	copper	copper	copper
Horizontal angle ±2°	37°	37°	143°
Vertical angle ±2°	30°	0°	150°
Position l/h/w [mm]	107/183/55	115/100/63	-107/183/55
[in]	4,2/7,2/2,2	4,5/3,9/2,5	-4,2/7,2/2,2
Straight tube l. [mm]	12	12	12
[in]	0,5	0,5	0,5

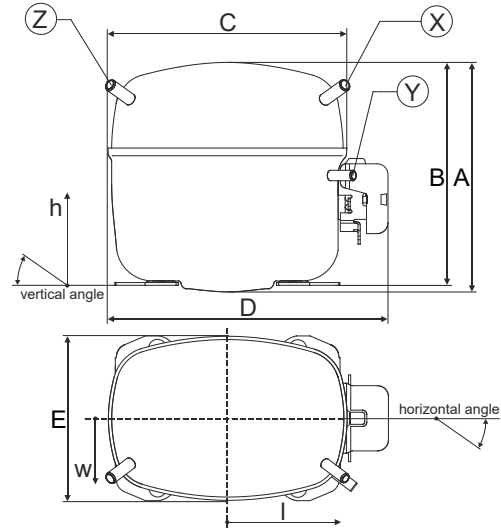

## Compressor fixation

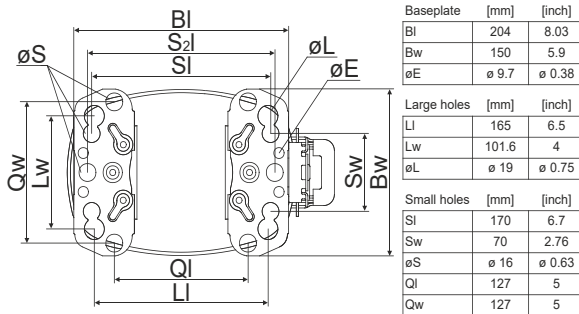

### Bolt joint

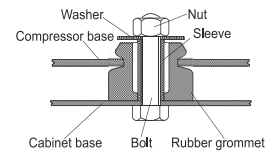

### Snap-on

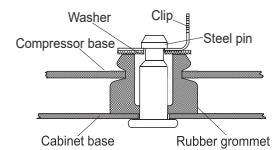

## Mounting accessories

Mounting accessories	one comp.	multi pack
Bolt joint   M6   ø16mm	118-1917	118-1918
Bolt joint   ø1/4"   ø16mm	118-1946	
Bolt joint   ø1/4"   ø19mm	118-1949	
Snap-on   ø7,3   ø16mm	118-1947	118-1919

## Application notes

LRA value on compressor label and datasheet may differ due to different test conditions for UL approval.

Provision for PE Grounding is located at the PE Stamp on the compressor

## Model

Designation	<b>SC12G</b>	<b>220-240V/50Hz</b>	<b>Conf. 1</b>	Sales code:	<b>104G8240</b>
-------------	--------------	----------------------	----------------	-------------	-----------------

## Configuration

Motorconfiguration	CSIR
Power supply (nominal)	220-240V/50Hz 1~
Refrigerant	R134a
Application	LBP+MBP+HBP
Voltage range	187-254V
Starting torque	HST
Approvals	VDE UL CCC EAC KC

## Electrical accessories / wiring diagram

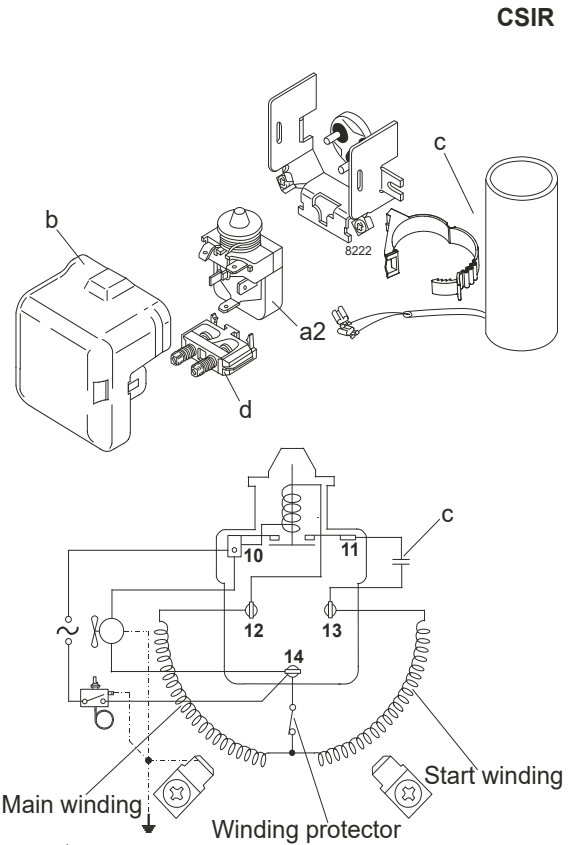

## Ambient/ machine room temperatures minimum /maximum

Ambient temperature range:	10 - 43°C / 50 - 110°F
Machine room temperature range:	10 - 48°C / 50 - 119°F
Compressor cooling:	fan 3m/s

## Operation Limits

### Operation pressure range

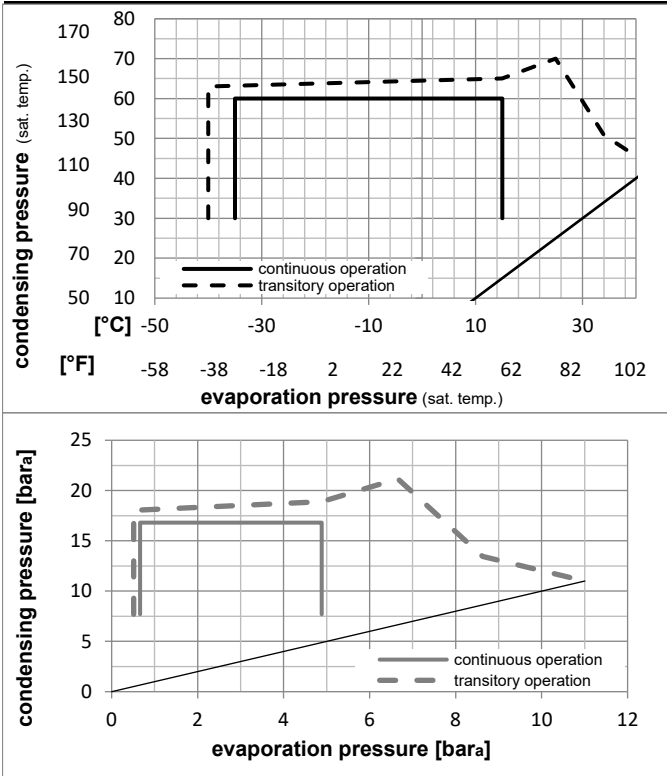

### Components

a2	assy. relay	117U6003
c	start capacitor (80μF)	117U5017
d	cord relief	103N1004
b	plastic cover	103N2009

### Model

Designation **SC12G** **220-240V/50Hz** Conf. 1 Sales code: **104G8240**

### Optimization + standard conditions

R134a, 220V/50Hz, CSIR, fan 3m/s, VDE, UL, CCC, EAC, KC

		Evaporating pressure (saturation temperature)				Condensing pressure (saturation temperature)			Return gas temp.			Liquid temp.			Cooling capacity			COP	EER	Power consumption			
		pe	pc	RGT	Tliq	[W]	[Btu/h]	[kcal/h]	[W/W]	[Btu/Wh]	[kcal/Wh]	P1	I	Ref. mass flow									
[°C]	[°F]											[W]	[A]	[kg/h]									
-23	-10	54	130	32	90	32	90	247,5	845	213,0	1,03	3,52	0,89	240,3	1,87	4,81						ASHRAE LBP	
-25	-13	55	131	32	90	55	131	175,0	598	150,6	0,77	2,63	0,66	226,8	1,83	4,18						cecomaf LBP	
-35	-31	40	104	20	68	40	104	123,3	421	106,1	0,75	2,55	0,64	165,0	1,73	2,70						EN12900 LBP	
-7	20	54	130	35	95	46	115	615,0	2100	529,3	1,60	5,47	1,38	383,9	2,34	13,42						ASHRAE MBP	
-10	14	55	131	32	90	55	131	464,1	1585	399,4	1,31	4,46	1,12	355,1	2,24	11,22						cecomaf MBP	
-10	14	45	113	20	68	45	113	547,2	1869	470,9	1,61	5,51	1,39	339,2	2,15	12,81						EN12900 MBP	

### Performance tables

R134a, 220V/50Hz, CSIR, fan 3m/s, VDE, UL, CCC, EAC, KC

	pe		Cooling capacity			COP	EER	P1	I	m	
	[°C]	[°F]	[W]	[Btu/h]	[kcal/h]	[W/W]	[Btu/Wh]	[kcal/Wh]	[W]	[A]	[kg/h]
[°C / °F]	-35	-31	102,6	350	88,3	0,65	2,21	0,56	158,5	1,69	2,21
cond. pressure	-25	-13	234,7	802	202,0	1,03	3,51	0,89	228,1	1,84	5,09
pc= 45/113	-15	5	435,5	1487	374,8	1,44	4,93	1,24	301,4	2,03	9,49
return gas temp.	-10	14	567,7	1939	488,5	1,67	5,71	1,44	339,2	2,15	12,42
RGT= 32/90	0	32	907,8	3100	781,2	2,18	7,44	1,88	416,6	2,42	20,07
liquid temp	5	41	1120,5	3827	964,3	2,46	8,39	2,11	456,0	2,58	24,95
Tliq= 45/113	15	59	1643,6	5613	1414,5	3,07	10,48	2,64	535,5	2,93	37,23
[°C / °F]	-35	-31	64,6	221	55,6	0,44	1,49	0,38	147,9	1,63	1,54
cond. pressure	-25	-13	175,0	598	150,6	0,77	2,63	0,66	226,8	1,83	4,18
pc= 55/131	-15	5	348,0	1188	299,5	1,12	3,82	0,96	311,1	2,09	8,38
return gas temp	-10	14	464,1	1585	399,4	1,31	4,46	1,12	355,1	2,24	11,22
RGT= 32/90	0	32	767,6	2621	660,6	1,72	5,88	1,48	446,1	2,57	18,77
liquid temp	5	41	959,8	3278	826,0	1,95	6,65	1,68	493,0	2,76	23,65
Tliq= 55/131	15	59	1437,3	4909	1237,0	2,44	8,34	2,10	588,7	3,17	36,10

## Model

Designation	<b>SC12G</b>	<b>208-230V/60Hz</b>	<b>Conf. 2</b>	Sales code:	<b>104G8240</b>
-------------	--------------	----------------------	----------------	-------------	-----------------

## Configuration

Motorconfiguration	CSIR
Power supply (nominal)	208-230V/60Hz 1~
Refrigerant	R134a
Application	LBP
Voltage range	198-254V
Starting torque	HST
Approvals	VDE UL CCC EAC KC

## Electrical accessories / wiring diagram

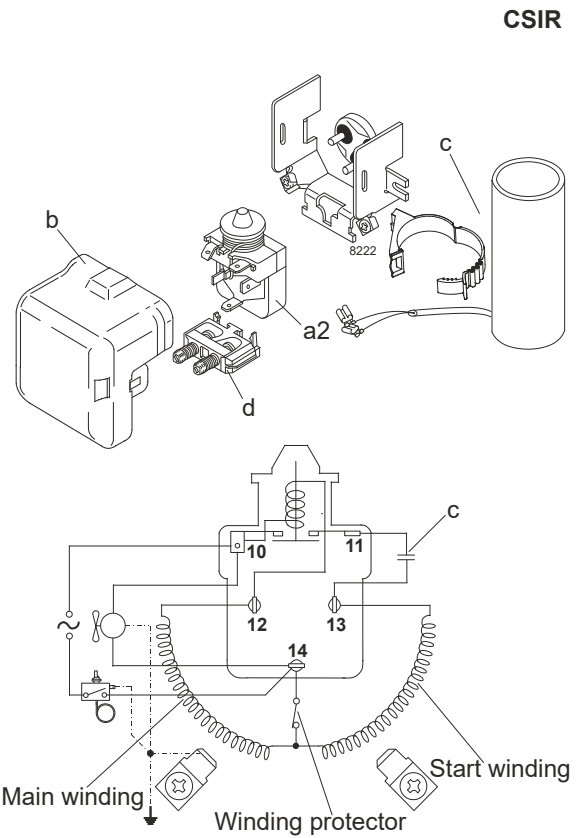

## Ambient/ machine room temperatures minimum /maximum

Ambient temperature range:	10 - 43°C / 50 - 110°F
Machine room temperature range:	10 - 48°C / 50 - 119°F
Compressor cooling:	fan 3m/s

## Operation Limits

## Operation pressure range

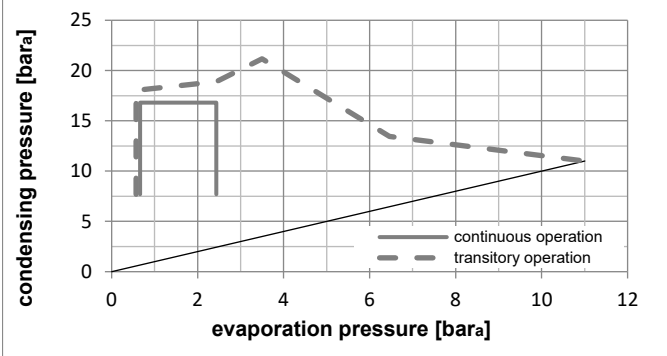
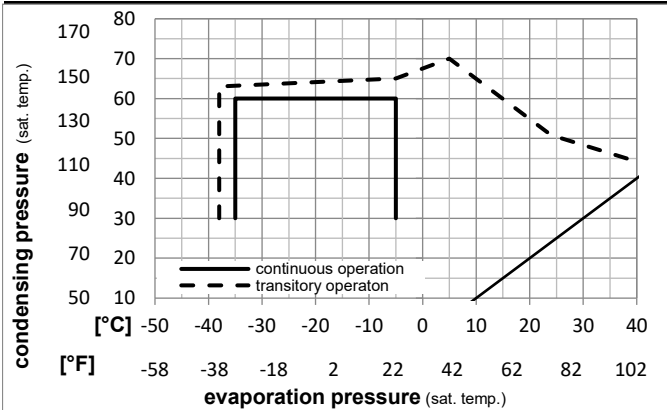

## Components

a2	assy. relay	117U6003
c	start capacitor (80μF)	117U5017
d	cord relief	103N1004
b	plastic cover	103N2009

### Model

Designation **SC12G** **208-230V/60Hz** Conf. 2 Sales code: **104G8240**

### Optimization + standard conditions

R134a, 230V/60Hz, CSIR, fan 3m/s, VDE, UL, CCC, EAC, KC

		Evaporating pressure (saturation temperature)				Condensing pressure (saturation temperature)					Power consumption				
		Return gas temp.				Liquid temp.					Current consumption				
		Cooling capacity				COP	EER		P1	I	Ref. mass flow				
		pe	pc	RGT	Tliq	[W]	[Btu/h]	[kcal/h]	[W/W]	[Btu/Wh]	[kcal/Wh]	[W]	[A]	[kg/h]	
[°C]	-23	54	32	32	288,0	983	247,8	1,03	3,51	0,88	280,6	2,06	5,59	ASHRAE LBP	
[°F]	-10	130	90	90											
[°C]	-25	55	32	55	203,3	694	175,0	0,77	2,62	0,66	264,7	2,01	4,86	cecomaf LBP	
[°F]	-13	131	90	131											
[°C]	-35	40	20	40	142,9	488	123,0	0,74	2,54	0,64	192,4	1,90	3,14	EN12900 LBP	
[°F]	-31	104	68	104											
[°C]	-7	54	35	46	718,1	2452	618,0	1,60	5,47	1,38	448,6	2,57	15,67	ASHRAE MBP	
[°F]	20	130	95	115											
[°C]	-10	55	32	55	541,6	1850	466,1	1,31	4,46	1,12	414,9	2,46	13,10	cecomaf MBP	
[°F]	14	131	90	131											
[°C]	-10	45	20	45	638,9	2182	549,8	1,61	5,51	1,39	396,3	2,36	14,95	EN12900 MBP	
[°F]	14	113	68	113											

### Performance tables

R134a, 230V/60Hz, CSIR, fan 3m/s, VDE, UL, CCC, EAC, KC

	pe		Cooling capacity			COP	EER		P1	I	m
	[°C]	[°F]	[W]	[Btu/h]	[kcal/h]	[W/W]	[Btu/Wh]	[kcal/Wh]	[W]	[A]	[kg/h]
[°C / °F]	-35	-31	118,7	405	102,2	0,64	2,19	0,55	184,8	1,86	2,56
cond. pressure	-30	-22	187,4	640	161,2	0,83	2,84	0,72	224,9	1,93	4,05
pc= 45/113	-25	-13	273,3	933	235,2	1,03	3,51	0,88	266,3	2,02	5,92
return gas temp.	-23	-10	306,9	1048	264,1	1,09	3,74	0,94	280,6	2,05	6,66
RGT= 32/90	-20	-4	379,3	1295	326,4	1,23	4,20	1,06	308,7	2,12	8,24
liquid temp	-15	5	508,2	1735	437,3	1,44	4,93	1,24	352,1	2,23	11,08
Tliq= 45/113	-5	23	846,1	2889	728,1	1,92	6,55	1,65	441,2	2,51	18,60
[°C / °F]	-35	-31	74,2	254	63,9	0,43	1,47	0,37	172,4	1,79	1,77
cond. pressure	-30	-22	131,0	448	112,8	0,60	2,06	0,52	217,7	1,89	3,13
pc= 55/131	-25	-13	203,3	694	175,0	0,77	2,62	0,66	264,7	2,01	4,86
return gas temp	-23	-10	232,0	792	199,6	0,83	2,82	0,71	281,0	2,06	5,55
RGT= 32/90	-20	-4	294,0	1004	253,0	0,94	3,20	0,81	313,3	2,15	7,05
liquid temp	-15	5	405,8	1386	349,2	1,12	3,81	0,96	363,4	2,30	9,77
Tliq= 55/131	-5	23	704,3	2405	606,1	1,51	5,14	1,30	467,5	2,64	17,12

## Model

Designation	<b>SC12G</b>	<b>220-240V/50Hz</b>	<b>Conf. 3</b>	Sales code:	<b>104G8240</b>
-------------	--------------	----------------------	----------------	-------------	-----------------

## Configuration

Motorconfiguration	CSIR
Power supply (nominal)	220-240V/50Hz 1~
Refrigerant	R513A
Application	LBP+MBP+HBP
Voltage range	187-254V
Starting torque	HST
Approvals	VDE UL CCC

## Electrical accessories / wiring diagram

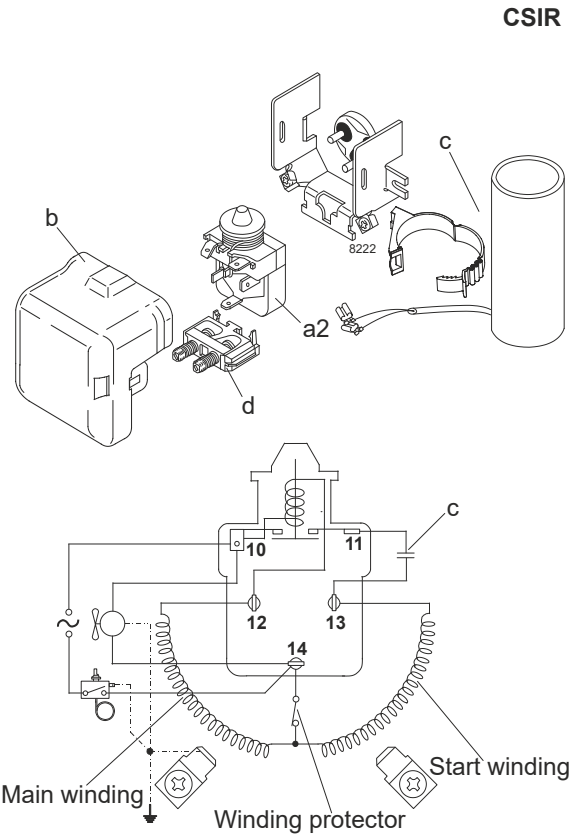

## Ambient/ machine room temperatures minimum /maximum

Ambient temperature range:	10 - 43°C / 50 - 110°F
Machine room temperature range:	10 - 48°C / 50 - 119°F
Compressor cooling:	fan 3m/s

## Operation Limits

## Operation pressure range

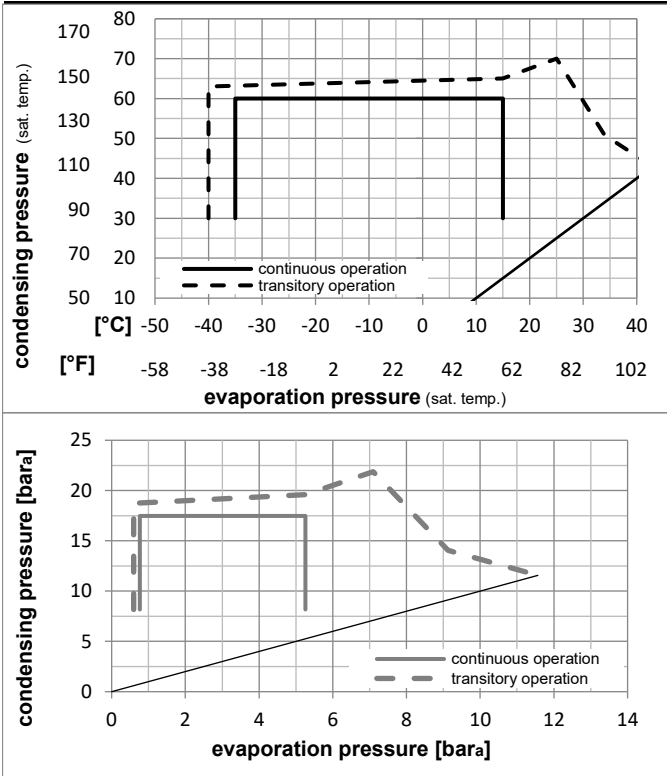

## Components

a2	assy. relay	117U6003
c	start capacitor (80μF)	117U5017
d	cord relief	103N1004
b	plastic cover	103N2009



## Model

Designation **SC12G** **220-240V/50Hz** Conf. 3 Sales code: **104G8240**

## Optimization + standard conditions

R513A, 220V/50Hz, CSIR, fan 3m/s, VDE, UL, CCC

		Evaporating pressure (saturation temperature)				Condensing pressure (saturation temperature)			Return gas temp.		Liquid temp.		Cooling capacity			COP	EER	Power consumption		
		pe	pc	RGT	Tliq	[W]	[Btu/h]	[kcal/h]	[W/W]	[Btu/Wh]	[kcal/Wh]	P1	I	m						
[°C]	[°F]	[°C]	[°F]	[°C]	[°F]							[W]	[A]	[kg/h]						
-23	-10	54	130	32	90	32	90	275,8	942	237,4	1,07	3,64	0,92	258,5	1,90	5,94				ASHRAE LBP
-25	-13	55	131	32	90	55	131	190,1	649	163,6	0,78	2,65	0,67	244,6	1,85	5,20				cecomaf LBP
-35	-31	40	104	20	68	40	104	139,6	477	120,2	0,78	2,68	0,68	178,0	1,62	3,45				EN12900 LBP
-7	20	54	130	35	95	46	115	646,9	2209	556,7	1,60	5,45	1,37	405,3	2,41	15,84				ASHRAE MBP
-10	14	55	131	32	90	55	131	482,7	1649	415,4	1,28	4,38	1,10	376,3	2,31	13,35				cecomaf MBP
-10	14	45	113	20	68	45	113	573,0	1957	493,1	1,60	5,46	1,38	358,4	2,25	15,19				EN12900 MBP

## Performance tables

R513A, 220V/50Hz, CSIR, fan 3m/s, VDE, UL, CCC

	pe		Cooling capacity			COP	EER	P1	I	m	
	[°C]	[°F]	[W]	[Btu/h]	[kcal/h]	[W/W]	[Btu/Wh]	[kcal/Wh]	[W]	[A]	[kg/h]
[°C / °F]	-35	-31	117,5	401	101,1	0,68	2,34	0,59	171,6	1,60	2,85
cond. pressure	-25	-13	256,8	877	221,0	1,05	3,59	0,90	244,4	1,85	6,26
pc= 45/113	-15	5	464,3	1586	399,6	1,45	4,96	1,25	319,9	2,12	11,38
return gas temp.	-10	14	599,1	2046	515,6	1,67	5,71	1,44	358,4	2,25	14,73
RGT= 32/90	0	32	942,4	3218	811,0	2,16	7,37	1,86	436,5	2,52	23,37
liquid temp	5	41	1155,3	3945	994,2	2,43	8,29	2,09	475,8	2,66	28,82
Tliq= 45/113	15	59	1674,8	5720	1441,4	3,02	10,31	2,60	554,6	2,94	42,37
[°C / °F]	-35	-31	74,9	256	64,5	0,46	1,58	0,40	161,8	1,56	2,04
cond. pressure	-25	-13	190,1	649	163,6	0,78	2,65	0,67	244,6	1,85	5,20
pc= 55/131	-15	5	366,2	1251	315,1	1,10	3,77	0,95	331,5	2,16	10,09
return gas temp	-10	14	482,7	1649	415,4	1,28	4,38	1,10	376,3	2,31	13,35
RGT= 32/90	0	32	784,0	2678	674,7	1,68	5,72	1,44	468,0	2,63	21,90
liquid temp	5	41	973,3	3324	837,6	1,89	6,46	1,63	514,7	2,80	27,35
Tliq= 55/131	15	59	1440,2	4919	1239,5	2,36	8,07	2,03	609,5	3,13	41,13

## Model

Designation	<b>SC12G</b>	<b>208-230V/60Hz</b>	<b>Conf. 4</b>	Sales code:	<b>104G8240</b>
-------------	--------------	----------------------	----------------	-------------	-----------------

## Configuration

Motorconfiguration	CSIR
Power supply (nominal)	208-230V/60Hz 1~
Refrigerant	R513A
Application	LBP
Voltage range	187-253V
Starting torque	HST
Approvals	VDE UL CCC

## Electrical accessories / wiring diagram

CSIR

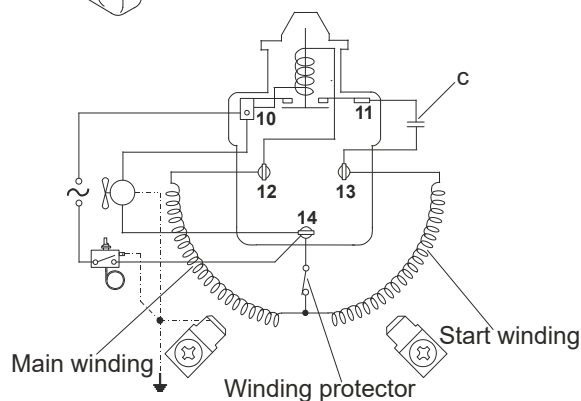
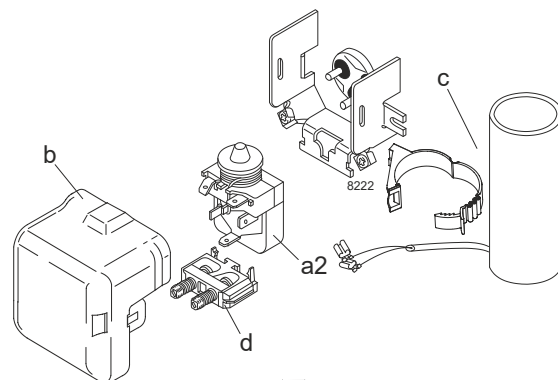

## Ambient/ machine room temperatures minimum /maximum

Ambient temperature range: 10 - 43°C / 50 - 110°F

Machine room temperature range: 10 - 48°C / 50 - 119°F

Compressor cooling: fan 3m/s

## Operation Limits

## Operation pressure range

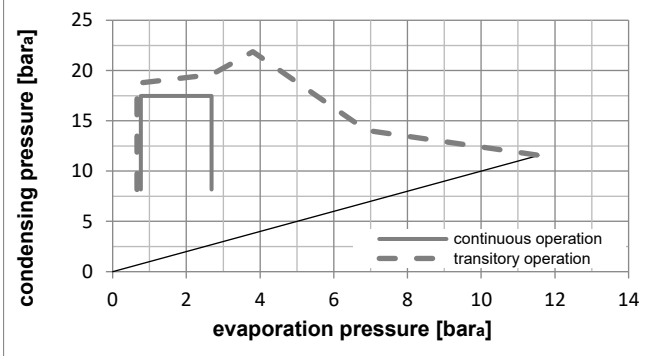
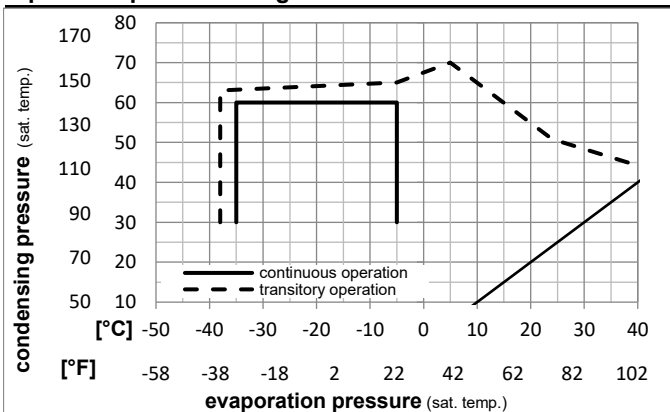

## Components

a2	assy. relay	117U6003
c	start capacitor (80μF)	117U5017
d	cord relief	103N1004
b	plastic cover	103N2009

## Model

Designation **SC12G** **208-230V/60Hz** Conf. 4 Sales code: **104G8240**

## Optimization + standard conditions

R513A, 230V/60Hz, CSIR, fan 3m/s, VDE, UL, CCC

		Evaporating pressure (saturation temperature)				Condensing pressure (saturation temperature)			Return gas temp.		Liquid temp.		Cooling capacity			COP	EER	Power consumption			
		pe	pc	RGT	Tliq	[W]	[Btu/h]	[kcal/h]	[W/W]	[Btu/Wh]	[kcal/Wh]	P1	I	m							
[°C]	[°F]	[°C]	[°F]	[°C]	[°F]							[W]	[A]	[kg/h]							
-23	54	32	32	320,8	1095	276,1	1,05	3,57	0,90	306,8	2,11	6,90	ASHRAE LBP								
-10	130	90	90																		
-25	55	32	55	220,8	754	190,0	0,76	2,60	0,65	290,6	2,06	6,05	cecomaf LBP								
-13	131	90	131																		
-35	40	20	40	162,0	553	139,4	0,77	2,62	0,66	211,5	1,80	4,01	EN12900 LBP								
-31	104	68	104																		
-7	54	35	46	755,0	2578	649,8	1,58	5,41	1,36	477,0	2,67	18,49	ASHRAE MBP								
20	130	95	115																		
-10	55	32	55	563,1	1923	484,6	1,27	4,34	1,09	443,4	2,56	15,57	cecomaf MBP								
14	131	90	131																		
-10	45	20	45	668,7	2284	575,5	1,58	5,41	1,36	422,4	2,49	17,72	EN12900 MBP								
14	113	68	113																		

## Performance tables

R513A, 230V/60Hz, CSIR, fan 3m/s, VDE, UL, CCC

	pe		Cooling capacity			COP	EER	P1	I	m	
	[°C]	[°F]	[W]	[Btu/h]	[kcal/h]	[W/W]	[Btu/Wh]	[kcal/Wh]	[W]	[A]	[kg/h]
[°C / °F]	-35	-31	136,0	465	117,1	0,67	2,27	0,57	204,5	1,77	3,30
cond. pressure	-30	-22	208,8	713	179,7	0,85	2,89	0,73	246,9	1,91	5,08
pc= 45/113	-25	-13	298,9	1021	257,3	1,03	3,52	0,89	289,9	2,05	7,29
return gas temp.	-23	-10	334,0	1141	287,4	1,10	3,74	0,94	304,7	2,10	8,15
RGT= 32/90	-20	-4	408,9	1397	351,9	1,23	4,19	1,06	333,6	2,20	9,99
liquid temp	-15	5	541,5	1849	466,0	1,43	4,90	1,23	377,7	2,34	13,27
Tliq= 45/113	-5	23	884,8	3022	761,5	1,89	6,47	1,63	467,4	2,64	21,84
[°C / °F]	-35	-31	86,2	294	74,2	0,44	1,52	0,38	193,9	1,74	2,35
cond. pressure	-30	-22	145,9	498	125,6	0,60	2,06	0,52	241,7	1,90	3,99
pc= 55/131	-25	-13	220,8	754	190,0	0,76	2,60	0,65	290,6	2,06	6,05
return gas temp	-23	-10	250,2	855	215,3	0,81	2,78	0,70	307,5	2,11	6,86
RGT= 32/90	-20	-4	313,6	1071	269,9	0,92	3,14	0,79	340,6	2,22	8,61
liquid temp	-15	5	426,8	1458	367,3	1,09	3,72	0,94	391,5	2,39	11,76
Tliq= 55/131	-5	23	725,2	2477	624,1	1,46	4,99	1,26	496,1	2,74	20,14

## Model

Designation	<b>SC12G</b>	<b>220-240V/50Hz</b>	<b>Conf. 5</b>	Sales code:	<b>104G8240</b>
-------------	--------------	----------------------	----------------	-------------	-----------------

## Configuration

Motorconfiguration	RSIR
Power supply (nominal)	220-240V/50Hz 1~
Refrigerant	R134a
Application	LBP+MBP+HBP
Voltage range	187-254V
Starting torque	LST
Approvals	VDE UL CCC EAC KC

## Electrical accessories / wiring diagram

RSIR

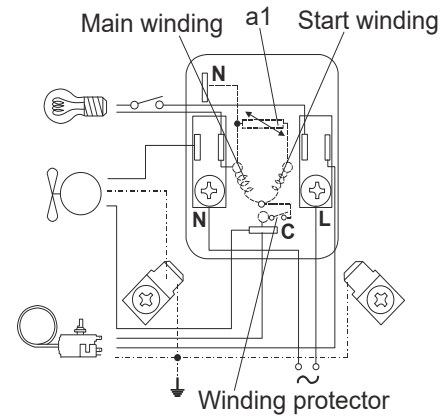
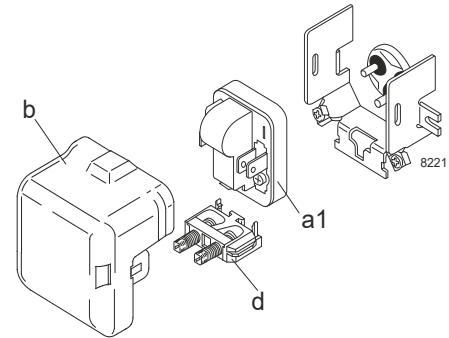

## Ambient/ machine room temperatures minimum /maximum

Ambient temperature range:	10 - 43°C / 50 - 110°F
Machine room temperature range:	10 - 48°C / 50 - 119°F
Compressor cooling:	fan 3m/s

## Operation Limits

### Operation pressure range

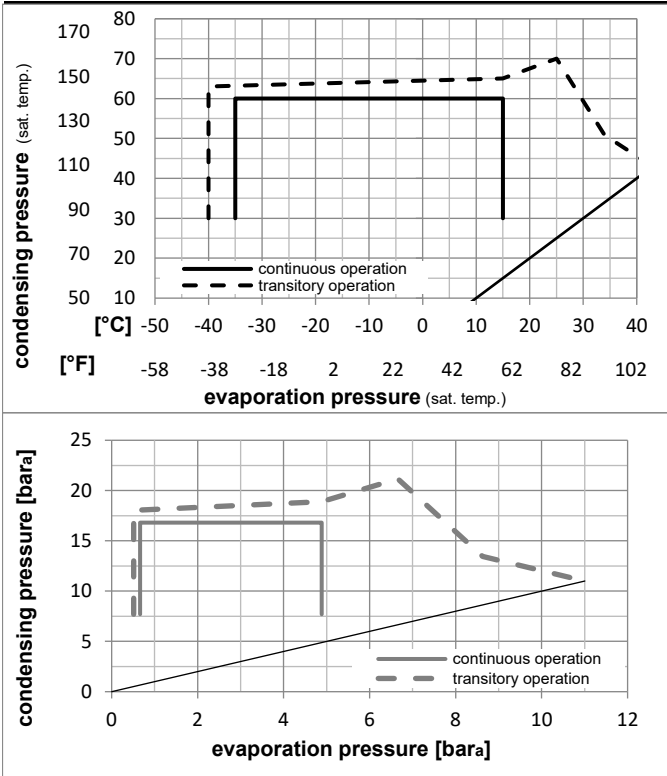

### Components

a1	PTC starter (220V, 25Ohm, 6.3mm)	103N0011
d	cord relief	103N1004
b	plastic cover	103N2009

## Model

Designation **SC12G** **220-240V/50Hz** Conf. 5 Sales code: **104G8240**

## Optimization + standard conditions

R134a, 220V/50Hz, RSIR, fan 3m/s, VDE, UL, CCC, EAC, KC

	Evaporating pressure (saturation temperature)				Cooling capacity			COP	EER	P1	Power consumption			ASHRAE LBP
	pe	pc	RGT	Tliq	[W]	[Btu/h]	[kcal/h]				l	Ref. mass flow		
[°C]	[°C]	[°C]	[°C]	[W]	[Btu/h]	[kcal/h]	[W/W]	[Btu/Wh]	[kcal/Wh]	[W]	[A]	[kg/h]		
[°F]	[°F]	[°F]	[°F]	[W]	[Btu/h]	[kcal/h]	[W/W]	[Btu/Wh]	[kcal/Wh]	[W]	[A]	[kg/h]	ASHRAE LBP	
-23	54	32	32	247,5	845	213,0	1,03	3,52	0,89	240,3	1,87	4,81	ASHRAE LBP	
-10	130	90	90											
-25	55	32	55	175,0	598	150,6	0,77	2,63	0,66	226,8	1,83	4,18	cecomaf LBP	
-13	131	90	131											
-35	40	20	40	123,3	421	106,1	0,75	2,55	0,64	165,0	1,73	2,70	EN12900 LBP	
-31	104	68	104											
-7	54	35	46	615,0	2100	529,3	1,60	5,47	1,38	383,9	2,34	13,42	ASHRAE MBP	
20	130	95	115											
-10	55	32	55	464,1	1585	399,4	1,31	4,46	1,12	355,1	2,24	11,22	cecomaf MBP	
14	131	90	131											
-10	45	20	45	547,2	1869	470,9	1,61	5,51	1,39	339,2	2,15	12,81	EN12900 MBP	
14	113	68	113											

## Performance tables

R134a, 220V/50Hz, RSIR, fan 3m/s, VDE, UL, CCC, EAC, KC

	pe		Cooling capacity			COP	EER	P1	l	m	
	[°C]	[°F]	[W]	[Btu/h]	[kcal/h]						
[°C / °F]	-35	-31	102,6	350	88,3	0,65	2,21	0,56	158,5	1,69	2,21
cond. pressure	-25	-13	234,7	802	202,0	1,03	3,51	0,89	228,1	1,84	5,09
pc= 45/113	-15	5	435,5	1487	374,8	1,44	4,93	1,24	301,4	2,03	9,49
return gas temp.	-10	14	567,7	1939	488,5	1,67	5,71	1,44	339,2	2,15	12,42
RGT= 32/90	0	32	907,8	3100	781,2	2,18	7,44	1,88	416,6	2,42	20,07
liquid temp	5	41	1120,5	3827	964,3	2,46	8,39	2,11	456,0	2,58	24,95
Tliq= 45/113	15	59	1643,6	5613	1414,5	3,07	10,48	2,64	535,5	2,93	37,23
[°C / °F]	-35	-31	64,6	221	55,6	0,44	1,49	0,38	147,9	1,63	1,54
cond. pressure	-25	-13	175,0	598	150,6	0,77	2,63	0,66	226,8	1,83	4,18
pc= 55/131	-15	5	348,0	1188	299,5	1,12	3,82	0,96	311,1	2,09	8,38
return gas temp	-10	14	464,1	1585	399,4	1,31	4,46	1,12	355,1	2,24	11,22
RGT= 32/90	0	32	767,6	2621	660,6	1,72	5,88	1,48	446,1	2,57	18,77
liquid temp	5	41	959,8	3278	826,0	1,95	6,65	1,68	493,0	2,76	23,65
Tliq= 55/131	15	59	1437,3	4909	1237,0	2,44	8,34	2,10	588,7	3,17	36,10



# SC Compressors





# SC Compressors

## Service/Repair – R290



8545



Secop accepts no responsibility for possible errors in catalogs, brochures, and other printed material. Secop reserves the right to alter its products without notice. This also applies to products already on order provided that such alterations can be made without subsequent changes being necessary to specifications already agreed. All trademarks in this material are the property of the respective companies. Secop and the Secop logotype are trademarks of Secop GmbH. All rights reserved. [www.secop.com](http://www.secop.com)