

Single Pack SC10GH 220-240V 50Hz / 208-230V 60Hz CSIR

Single pack code number: **195B4073**

Position	Title	Code	Amount
1	Compressor SC10GH	104G8041	1
2	Starting relay	117U6005	1
3	Starting capacitor (80 μ F 220V, 6.3mm)	117U5017	1
4	Cord relief	103N1004	1
5	Cover	103N2008	1
6	Bolt joint for one compressor M6 \varnothing 16mm	118-1917	1

Secop GmbH • Lise-Meitner-Straße 29 • 24941 Flensburg, Germany • Tel: +49 461 4941 0 • www.secop.com

Secop accepts no responsibility for possible errors in catalogs, brochures, and other printed material. Secop reserves the right to alter its products without notice. This also applies to products already on order provided that such alterations can be made without subsequent changes being necessary to specifications already agreed. All trademarks in this material are the property of the respective companies. Secop and the Secop logotype are trademarks of Secop GmbH. All rights reserved.

Model

Designation	SC10GH	220-240V/50Hz 1~ 208-230V/60Hz 1~	Sales code:	104G8041
-------------	---------------	-----------------------------------	-------------	-----------------

Compressor design

Oil type	Polyolester	Refrigerant(s)	R134a, R513A
Oil viscosity	22cST	Displacement	10,29cm ³ / 0,63cu.in
Oil quantity	504cm ³ / 17fl.oz	Compressors on pallet	80
Refr. charge - tech. limit	1300g / 45,9oz		
Free gas volume comp.	1510cm ³ / 51,1fl.oz		
Weight	12,8kg / 28,2lbs		
Motor protection	1# internal		
Winding resistance main	5,13Ω (at 25°C)		
Winding resistance aux	13,51Ω (at 25°C)		
Max. winding temp.	125°C / 257°F		
Max. discharge temp.	130°C / 266°F		



General - Configurations with SC10GH

	Conf. 1	Conf. 2	Conf. 3	Conf. 4
Motorconfiguration	CSIR	CSIR	CSIR	CSIR
Power supply (nominal)	220-240V/50Hz	220-240V/50Hz	208-230V/60Hz	208-230V/60Hz
Number of phases	1	1	1	1
Voltage range	198-254V	198-254V	198-254V	198-254V
Approvals	VDE, UL, CCC, KC	VDE, UL, CCC	VDE, UL, CCC, KC	VDE, UL, CCC
Starting torque	HST	HST	HST	HST
Note	- / -			

Applications with SC10GH

	Conf. 1	Conf. 2	Conf. 3	Conf. 4
Refrigerant	R134a	R513A	R134a	R513A
Application	HBP	HBP	HBP	HBP
System cooling	fan 3m/s	fan 3m/s	fan 3m/s	fan 3m/s
Hot gas defrost	OK	OK	OK	OK
Long interval pull down	OK	OK	OK	OK

Electrical data - Configurations with SC10GH

	Conf. 1	Conf. 2	Conf. 3	Conf. 4
Starting device type	relay	relay	relay	relay
Run capacitor	- / -	- / -	- / -	- / -
Start capacitor	80μF	80μF	80μF	80μF
LRA (locked rotor amps / 4s)	16,2A	16,2A	15,6A	15,6A
RLA (rated load amps / 1s)	3,1A	3,1A	2,8A	2,8A
Cut in current	16,2A	16,2A	15,6A	15,6A

Model

Designation

SC10GH

220-240V/50Hz 1~ 208-230V/60Hz 1~

Sales code:

104G8041

Compressor dimensions

Housing	A Height	209mm / 8,23in
	B Height	203mm / 7,99in
	C Length shell	218mm / 8,58in
	D Length w. cover	255mm / 10,04in
	E Width	151mm / 5,94in

Connectors	Suction X	Discharge Y	Process Z
Diameter [mm]	øi 10,11-10,29	øi 8,11-8,29	øi 6,11-6,29
(i:inside, o:outside) [in]	øi 0,4-0,41	øi 0,32-0,33	øi 0,24-0,25
Material	copper	copper	copper
Horizontal angle ±2°	37°	37°	143°
Vertical angle ±2°	30°	0°	150°
Position l/h/w [mm]	107/183/55	115/100/63	-107/183/55
[in]	4,2/7,2/2,2	4,5/3,9/2,5	-4,2/7,2/2,2
Straight tube l. [mm]	12	12	12
[in]	0,5	0,5	0,5



Compressor fixation



Bolt joint



Snap-on



Mounting accessories

Mounting accessories	one comp.	multi pack
Bolt joint M6 ø16mm	118-1917	118-1918
Bolt joint ø1/4" ø16mm	118-1946	
Bolt joint ø1/4" ø19mm	118-1949	
Snap-on ø7,3 ø16mm	118-1947	118-1919

Application notes

Provision for PE Grounding is located at the PE Stamp on the compressor

Model

Designation	SC10GH	220-240V/50Hz	Conf. 1	Sales code:	104G8041
-------------	---------------	----------------------	----------------	-------------	-----------------

Configuration

Motorconfiguration	CSIR
Power supply (nominal)	220-240V/50Hz 1~
Refrigerant	R134a
Application	HBP
Voltage range	198-254V
Starting torque	HST
Approvals	VDE UL CCC KC

Electrical accessories / wiring diagram



Ambient/ machine room temperatures minimum /maximum

Ambient temperature range:	10 - 43°C / 50 - 110°F
Machine room temperature range:	10 - 48°C / 50 - 119°F
Compressor cooling:	fan 3m/s

Operation Limits

Operation pressure range

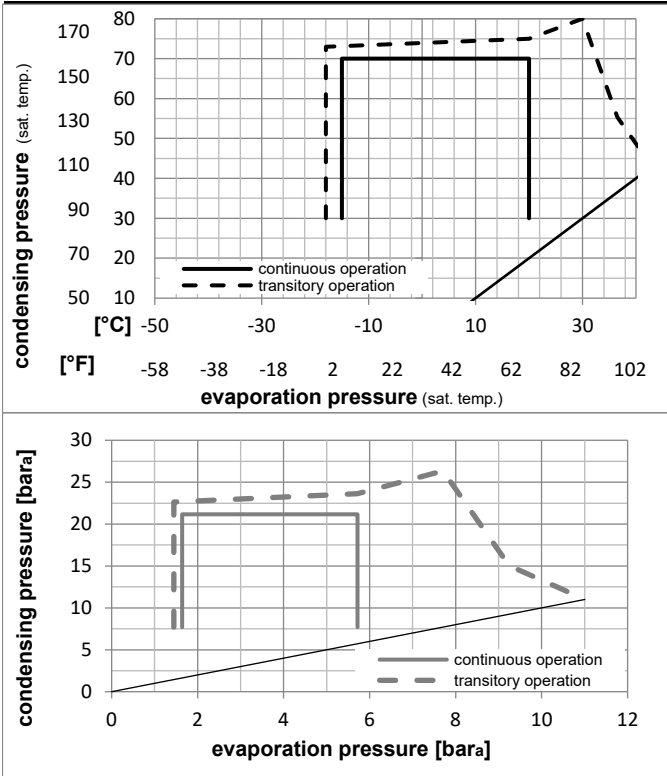

Components

a2	relay	117U6005
c	start capacitor (80μF)	117U5017
d	cord relief	103N1004
b	plastic cover	103N2008

Model

Designation **SC10GH** **220-240V/50Hz** Conf. 1 Sales code: **104G8041**

Optimization + standard conditions

R134a, 220V/50Hz, CSIR, fan 3m/s, VDE, UL, CCC, KC

		Evaporating pressure (saturation temperature)				Condensing pressure (saturation temperature)			Return gas temp.			Liquid temp.			Cooling capacity			COP	EER	Power consumption			
		pe	pc	RGT	Tliq	[W]	[Btu/h]	[kcal/h]	[W/W]	[Btu/Wh]	[kcal/Wh]	P1	I	Ref. mass flow									
[°C]	[°F]											[W]	[A]	[kg/h]									
7,2	45	54	35	46	925,4	3160	796,4	2,28	7,77	1,96	406,7	3,34	20,53	ASHRAE HBP									
5	41	55	32	55	761,6	2601	655,5	1,93	6,59	1,66	395,0	3,26	18,77	cecomaf HBP									
5	41	50	20	50	794,7	2714	683,9	2,11	7,21	1,82	376,2	3,13	20,02	EN12900 HBP									
-7	20	54	35	46	481,8	1646	414,7	1,56	5,34	1,35	308,0	2,72	10,51	ASHRAE MBP									
-10	14	55	32	55	352,2	1203	303,1	1,25	4,28	1,08	280,7	2,57	8,52	cecomaf MBP									
-10	14	45	20	45	407,4	1391	350,6	1,51	5,15	1,30	269,9	2,51	9,54	EN12900 MBP									

Performance tables

R134a, 220V/50Hz, CSIR, fan 3m/s, VDE, UL, CCC, KC

	pe		Cooling capacity			COP	EER	P1	I	m	
	[°C]	[°F]	[W]	[Btu/h]	[kcal/h]	[W/W]	[Btu/Wh]	[kcal/Wh]	[W]	[A]	[kg/h]
[°C / °F]	-15	5	294,5	1006	253,5	1,26	4,32	1,09	232,9	2,34	6,42
cond. pressure	-10	14	422,7	1444	363,8	1,57	5,35	1,35	269,9	2,51	9,25
pc= 45/113	-5	23	564,2	1927	485,6	1,86	6,36	1,60	303,2	2,68	12,41
return gas temp.	0	32	722,6	2468	621,9	2,17	7,42	1,87	332,7	2,85	15,98
RGT= 32/90	5	41	901,5	3079	775,8	2,51	8,59	2,16	358,6	3,01	20,07
liquid temp	15	59	1334,5	4558	1148,5	3,34	11,42	2,88	399,0	3,33	30,23
Tliq= 45/113	20	68	1595,8	5450	1373,4	3,86	13,18	3,32	413,7	3,48	36,55
[°C / °F]	-15	5	233,0	796	200,5	0,99	3,38	0,85	235,2	2,34	5,61
cond. pressure	-10	14	352,2	1203	303,1	1,25	4,28	1,08	280,7	2,57	8,52
pc= 55/131	-5	23	477,7	1631	411,1	1,48	5,06	1,27	322,6	2,80	11,61
return gas temp	0	32	613,0	2093	527,5	1,70	5,80	1,46	360,6	3,03	14,99
RGT= 32/90	5	41	761,6	2601	655,5	1,93	6,59	1,66	395,0	3,26	18,77
liquid temp	15	59	1113,1	3801	957,9	2,46	8,40	2,12	452,6	3,70	27,96
Tliq= 55/131	20	68	1323,0	4518	1138,6	2,78	9,50	2,39	475,7	3,92	33,64

Model

Designation	SC10GH	220-240V/50Hz	Conf. 2	Sales code:	104G8041
-------------	---------------	----------------------	----------------	-------------	-----------------

Configuration

Motorconfiguration	CSIR
Power supply (nominal)	220-240V/50Hz 1~
Refrigerant	R513A
Application	HBP
Voltage range	198-254V
Starting torque	HST
Approvals	VDE UL CCC

Electrical accessories / wiring diagram

CSIR



Ambient/ machine room temperatures minimum /maximum

Ambient temperature range:	10 - 43°C / 50 - 110°F
Machine room temperature range:	10 - 48°C / 50 - 119°F
Compressor cooling:	fan 3m/s

Operation Limits

Operation pressure range

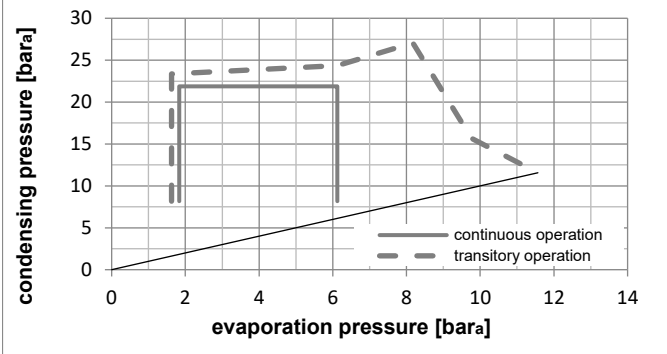
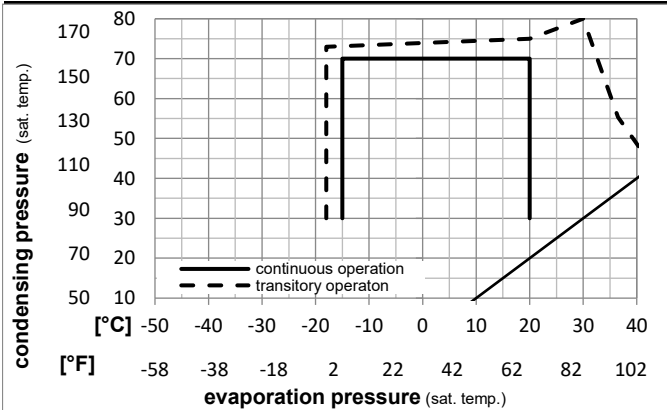

Components

a2	relay	117U6005
c	start capacitor (80μF)	117U5017
d	cord relief	103N1004
b	plastic cover	103N2008

Model

Designation **SC10GH** **220-240V/50Hz** Conf. 2 Sales code: **104G8041**

Optimization + standard conditions

R513A, 220V/50Hz, CSIR, fan 3m/s, VDE, UL, CCC

		Evaporating pressure (saturation temperature)				Condensing pressure (saturation temperature)			Return gas temp.			Liquid temp.			Cooling capacity			COP	EER	Power consumption			
		pe	pc	RGT	Tliq	[W]	[Btu/h]	[kcal/h]	[W/W]	[Btu/Wh]	[kcal/Wh]	P1	I	m	[W]	[A]	[kg/h]						
[°C]	[°F]																						
7,2	45	54	35	46	952,4	3252	819,6	2,24	7,66	1,93	424,4	3,49	23,66								ASHRAE HBP		
5	41	55	32	55	772,4	2638	664,7	1,87	6,38	1,61	413,2	3,42	21,71								cecomaf HBP		
5	41	50	20	50	807,0	2756	694,5	2,05	7,01	1,77	393,3	3,29	23,14								EN12900 HBP		
-7	20	54	35	46	506,5	1730	435,9	1,55	5,30	1,34	326,4	2,87	12,41								ASHRAE MBP		
-10	14	55	32	55	366,1	1250	315,1	1,23	4,18	1,05	298,8	2,70	10,12								cecomaf MBP		
-10	14	45	20	45	426,4	1456	367,0	1,49	5,08	1,28	286,5	2,62	11,30								EN12900 MBP		

Performance tables

R513A, 220V/50Hz, CSIR, fan 3m/s, VDE, UL, CCC

	pe		Cooling capacity			COP	EER	P1			I	m
	[°C]	[°F]	[W]	[Btu/h]	[kcal/h]	[W/W]	[Btu/Wh]	[kcal/Wh]	[W]	[A]	[kg/h]	
[°C / °F]	-15	5	314,1	1073	270,3	1,26	4,32	1,09	248,4	2,38	7,70	
cond. pressure	-10	14	445,9	1523	383,7	1,56	5,31	1,34	286,5	2,62	10,96	
pc= 45/113	-5	23	590,0	2015	507,7	1,84	6,29	1,59	320,2	2,83	14,56	
return gas temp.	0	32	749,9	2561	645,4	2,15	7,33	1,85	349,6	3,02	18,60	
RGT= 32/90	5	41	929,2	3173	799,7	2,48	8,47	2,13	374,8	3,18	23,18	
liquid temp	15	59	1360,1	4645	1170,5	3,29	11,23	2,83	413,6	3,42	34,41	
Tliq= 45/113	20	68	1618,7	5528	1393,1	3,79	12,94	3,26	427,4	3,51	41,33	
[°C / °F]	-15	5	245,2	838	211,0	0,97	3,33	0,84	251,8	2,40	6,76	
cond. pressure	-10	14	366,1	1250	315,1	1,23	4,18	1,05	298,8	2,70	10,12	
pc= 55/131	-5	23	491,9	1680	423,3	1,44	4,92	1,24	341,2	2,96	13,66	
return gas temp	0	32	626,1	2138	538,8	1,65	5,64	1,42	379,3	3,20	17,49	
RGT= 32/90	5	41	772,4	2638	664,7	1,87	6,38	1,61	413,2	3,42	21,71	
liquid temp	15	59	1115,1	3808	959,7	2,38	8,12	2,05	469,0	3,77	31,85	
Tliq= 55/131	20	68	1318,6	4503	1134,8	2,68	9,17	2,31	491,2	3,91	38,05	

Model

Designation	SC10GH	208-230V/60Hz	Conf. 3	Sales code:	104G8041
-------------	---------------	----------------------	----------------	-------------	-----------------

Configuration

Motorconfiguration	CSIR
Power supply (nominal)	208-230V/60Hz 1~
Refrigerant	R134a
Application	HBP
Voltage range	198-254V
Starting torque	HST
Approvals	VDE UL CCC KC

Electrical accessories / wiring diagram

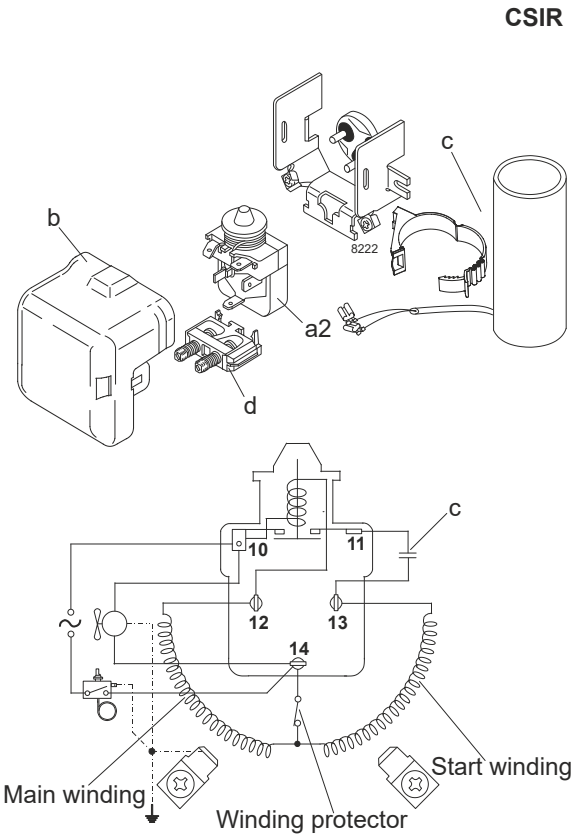

Ambient/ machine room temperatures minimum /maximum

Ambient temperature range:	10 - 43°C / 50 - 110°F
Machine room temperature range:	10 - 48°C / 50 - 119°F
Compressor cooling:	fan 3m/s

Operation Limits

Operation pressure range

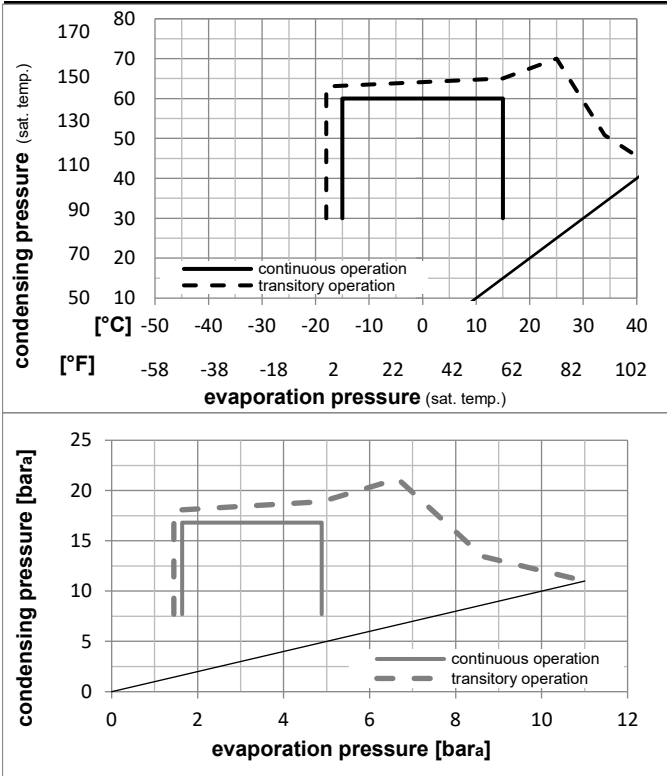

Components

a2	relay	117U6005
c	start capacitor (80μF)	117U5017
d	cord relief	103N1004
b	plastic cover	103N2008

Model

Designation **SC10GH** **208-230V/60Hz** Conf. 3 Sales code: **104G8041**

Optimization + standard conditions

R134a, 230V/60Hz, CSIR, fan 3m/s, VDE, UL, CCC, KC

		Evaporating pressure (saturation temperature)				Condensing pressure (saturation temperature)			Return gas temp.			Liquid temp.			Cooling capacity			COP	EER	Power consumption			
		pe	pc	RGT	Tliq	[W]	[Btu/h]	[kcal/h]	[W/W]	[Btu/Wh]	[kcal/Wh]	P1	I	m	[W]	[A]	[kg/h]						
[°C]	[°F]																						
7,2	45	54	35	46	1037,8	3544	893,1	2,02	6,89	1,74	514,2	3,27	23,02								ASHRAE HBP		
5	41	55	32	55	848,9	2899	730,6	1,71	5,85	1,47	495,5	3,18	20,92								cecomaf HBP		
5	41	50	20	50	907,1	3098	780,6	1,94	6,62	1,67	468,2	2,91	22,86								EN12900 HBP		
-7	20	54	35	46	556,2	1899	478,6	1,49	5,08	1,28	374,2	2,52	12,13								ASHRAE MBP		
-10	14	55	32	55	420,5	1436	361,9	1,24	4,23	1,07	339,6	2,37	10,17								cecomaf MBP		
-10	14	45	20	45	515,6	1761	443,7	1,53	5,23	1,32	336,8	2,19	12,07								EN12900 MBP		

Performance tables

R134a, 230V/60Hz, CSIR, fan 3m/s, VDE, UL, CCC, KC

	pe		Cooling capacity			COP	EER	P1	I	m	
	[°C]	[°F]	[W]	[Btu/h]	[kcal/h]	[W/W]	[Btu/Wh]	[kcal/Wh]	[W]	[A]	[kg/h]
[°C / °F]	-15	5	420,8	1437	362,2	1,40	4,78	1,20	300,8	2,05	9,17
cond. pressure	-10	14	534,9	1827	460,3	1,59	5,42	1,37	336,8	2,19	11,71
pc= 45/113	-5	23	673,9	2302	580,0	1,81	6,18	1,56	372,7	2,35	14,82
return gas temp.	0	32	840,8	2871	723,6	2,06	7,04	1,77	408,0	2,52	18,59
RGT= 32/90	5	41	1038,3	3546	893,6	2,35	8,02	2,02	442,2	2,69	23,12
liquid temp	10	50	1269,4	4335	1092,4	2,67	9,13	2,30	474,7	2,88	28,48
Tliq= 45/113	15	59	1536,8	5249	1322,6	3,04	10,39	2,62	505,0	3,07	34,81
[°C / °F]	-15	5	318,4	1087	274,0	1,11	3,79	0,95	287,2	2,13	7,66
cond. pressure	-10	14	420,5	1436	361,9	1,24	4,23	1,07	339,6	2,37	10,17
pc= 55/131	-5	23	541,1	1848	465,7	1,38	4,71	1,19	392,1	2,63	13,15
return gas temp	0	32	682,9	2332	587,7	1,54	5,25	1,32	444,3	2,90	16,70
RGT= 32/90	5	41	848,9	2899	730,6	1,71	5,85	1,47	495,5	3,18	20,92
liquid temp	10	50	1041,9	3558	896,6	1,91	6,53	1,64	545,3	3,46	25,90
Tliq= 55/131	15	59	1264,7	4319	1088,4	2,13	7,28	1,84	593,1	3,76	31,77

Model

Designation	SC10GH	208-230V/60Hz	Conf. 4	Sales code:	104G8041
-------------	---------------	----------------------	----------------	-------------	-----------------

Configuration

Motorconfiguration	CSIR
Power supply (nominal)	208-230V/60Hz 1~
Refrigerant	R513A
Application	HBP
Voltage range	198-254V
Starting torque	HST
Approvals	VDE UL CCC

Electrical accessories / wiring diagram

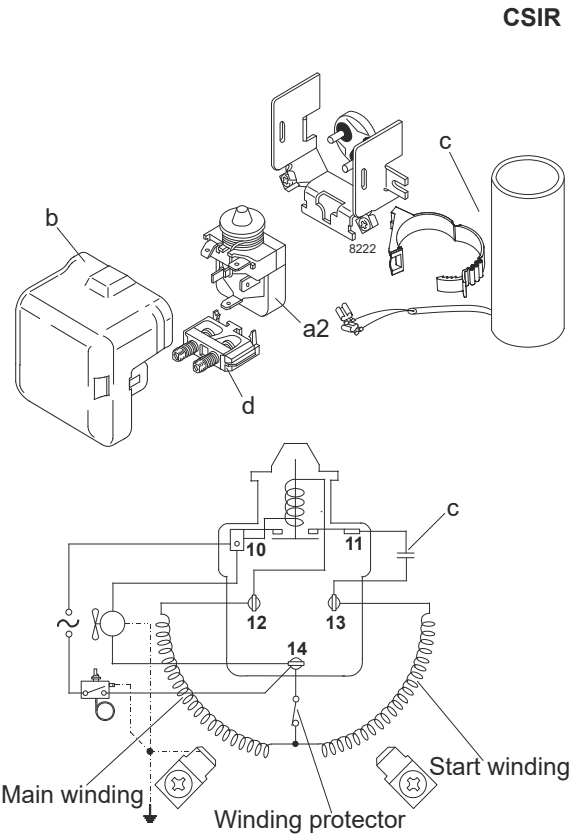

Ambient/ machine room temperatures minimum /maximum

Ambient temperature range:	10 - 43°C / 50 - 110°F
Machine room temperature range:	10 - 48°C / 50 - 119°F
Compressor cooling:	fan 3m/s

Operation Limits

Operation pressure range

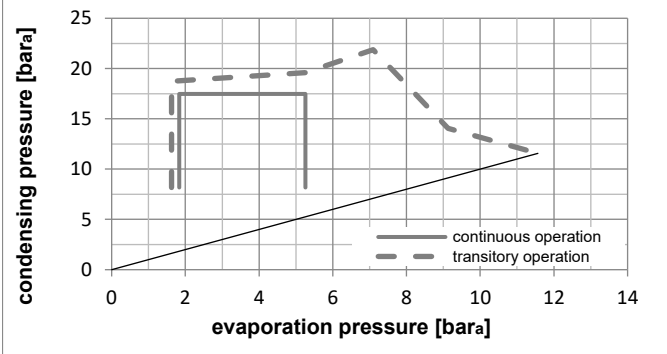
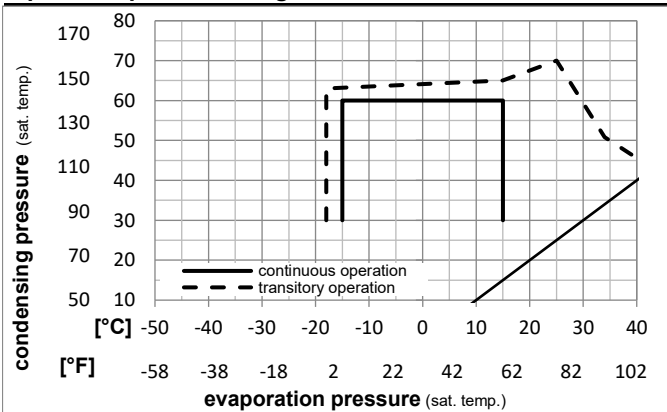

Components

a2	relay	117U6005
c	start capacitor (80μF)	117U5017
d	cord relief	103N1004
b	plastic cover	103N2008

Model

Designation **SC10GH** **208-230V/60Hz** Conf. 4 Sales code: **104G8041**

Optimization + standard conditions

R513A, 230V/60Hz, CSIR, fan 3m/s, VDE, UL, CCC

		Evaporating pressure (saturation temperature)				Condensing pressure (saturation temperature)			Return gas temp.			Liquid temp.			Cooling capacity			COP	EER	Power consumption			
		pe	pc	RGT	Tliq	[W]	[Btu/h]	[kcal/h]	[W/W]	[Btu/Wh]	[kcal/Wh]	P1	I	m	[W]	[A]	[kg/h]						
[°C]	[°F]																						
7,2	45	54	35	46	1068,1	3648	919,2	1,99	6,79	1,71	537,1	3,39	26,53								ASHRAE HBP		
5	41	55	32	55	860,9	2940	740,9	1,66	5,67	1,43	518,7	3,29	24,19								cecomaf HBP		
5	41	50	20	50	921,4	3147	793,0	1,88	6,42	1,62	490,1	3,13	26,42								EN12900 HBP		
-7	20	54	35	46	584,9	1997	503,3	1,47	5,03	1,27	396,7	2,62	14,33								ASHRAE MBP		
-10	14	55	32	55	437,3	1494	376,4	1,21	4,13	1,04	361,5	2,42	12,09								cecomaf MBP		
-10	14	45	20	45	539,8	1843	464,5	1,51	5,15	1,30	357,8	2,40	14,31								EN12900 MBP		

Performance tables

R513A, 230V/60Hz, CSIR, fan 3m/s, VDE, UL, CCC

	pe		Cooling capacity			COP	EER	P1			I	m
	[°C]	[°F]	[W]	[Btu/h]	[kcal/h]	[W/W]	[Btu/Wh]	[kcal/Wh]	[W]	[A]	[kg/h]	
[°C / °F]	-15	5	448,6	1532	386,0	1,40	4,77	1,20	321,0	2,20	10,99	
cond. pressure	-10	14	564,5	1928	485,8	1,58	5,39	1,36	357,8	2,40	13,88	
pc= 45/113	-5	23	705,0	2408	606,7	1,79	6,11	1,54	394,0	2,60	17,40	
return gas temp.	0	32	872,9	2981	751,2	2,03	6,95	1,75	429,1	2,79	21,65	
RGT= 32/90	5	41	1070,6	3656	921,4	2,31	7,90	1,99	462,8	2,98	26,70	
liquid temp	10	50	1301,0	4443	1119,7	2,63	8,99	2,26	494,5	3,15	32,66	
Tliq= 45/113	15	59	1566,6	5350	1348,2	2,99	10,21	2,57	523,8	3,31	39,64	
[°C / °F]	-15	5	335,2	1145	288,4	1,09	3,72	0,94	307,5	2,13	9,23	
cond. pressure	-10	14	437,3	1494	376,4	1,21	4,13	1,04	361,5	2,42	12,09	
pc= 55/131	-5	23	557,3	1903	479,6	1,34	4,59	1,16	415,0	2,72	15,48	
return gas temp	0	32	697,6	2382	600,3	1,49	5,10	1,28	467,5	3,01	19,48	
RGT= 32/90	5	41	860,9	2940	740,9	1,66	5,67	1,43	518,7	3,29	24,19	
liquid temp	10	50	1049,9	3586	903,6	1,85	6,31	1,59	568,1	3,56	29,73	
Tliq= 55/131	15	59	1267,3	4328	1090,6	2,06	7,03	1,77	615,2	3,82	36,19	



SC Compressors

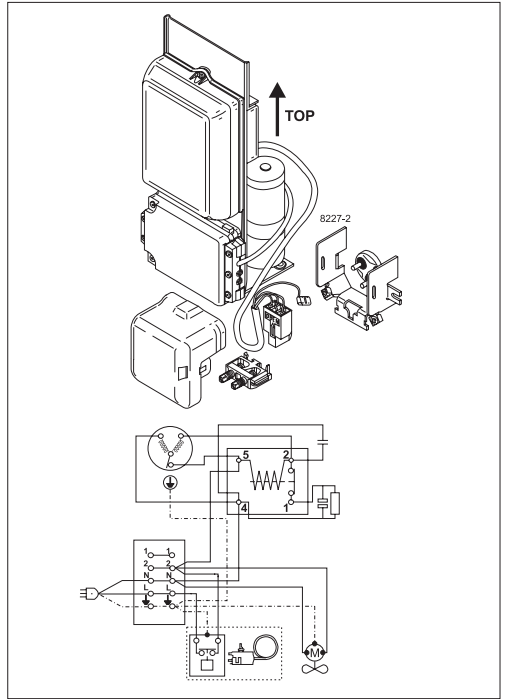



SC Compressors

Service/Repair – R290



8545

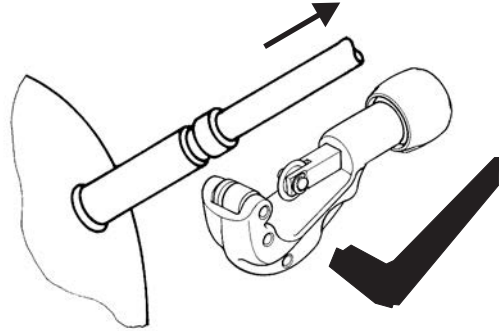

Secop accepts no responsibility for possible errors in catalogs, brochures, and other printed material. Secop reserves the right to alter its products without notice. This also applies to products already on order provided that such alterations can be made without subsequent changes being necessary to specifications already agreed. All trademarks in this material are the property of the respective companies. Secop and the Secop logotype are trademarks of Secop GmbH. All rights reserved. www.secop.com