

Single Pack TLES5.7FT.3 220-240V 50Hz RSIR

Single pack code number: **195B4441**

Position	Title	Code	Amount
1	Compressor TLES5.7FT.3	102G4615	1
2	PTC starting device (220V, 250hm, 4.8mm)	103N0021	1
3	Protection screen for PTC	103N0476	1
4	Cord relief	103N1010	1
5	Cover	103N2010	1
6	Bolt joint for one compressor M6 ø16mm	118-1917	1

Secop GmbH • Lise-Meitner-Straße 29 • 24941 Flensburg, Germany • Tel: +49 461 4941 0 • www.secop.com

Secop accepts no responsibility for possible errors in catalogs, brochures, and other printed material. Secop reserves the right to alter its products without notice. This also applies to products already on order provided that such alterations can be made without subsequent changes being necessary to specifications already agreed. All trademarks in this material are the property of the respective companies. Secop and the Secop logotype are trademarks of Secop GmbH. All rights reserved.

Model

Designation	TLES5.7FT.3 220-240V/50Hz 1~	Sales code:	102G4615
-------------	-------------------------------------	-------------	-----------------

Compressor design

Oil type	Polyolester	Refrigerant(s)	R134a, 0
Oil viscosity	15cST	Displacement	5,7cm ³ / 0,35cu.in
Oil quantity	184cm ³ / 6,2fl.oz	Compressors on pallet	125
Refr. charge - tech. limit	400g / 14,1oz		
Free gas volume comp.	1790cm ³ / 60,5fl.oz		
Weight	7,5kg / 16,5lbs		
Motor protection	1# internal		
Winding resistance main	14,5Ω (at 25°C)		
Winding resistance aux	14,8Ω (at 25°C)		
Max. winding temp.	125°C / 257°F		
Max. discharge temp.	130°C / 266°F		



General - Configurations with TLES5.7FT.3

	Conf. 1	Conf. 2	Conf. 3
Motorconfiguration	RSIR	CSIR	RSCR
Power supply (nominal)	220-240V/50Hz	220-240V/50Hz	220-240V/50Hz
Number of phases	1	1	1
Voltage range	187-254V	187-254V	187-254V
Approvals	VDE, EAC	VDE, EAC	VDE, EAC
Starting torque	LST	HST	LST
Note	- / -		

Applications with TLES5.7FT.3

	Conf. 1	Conf. 2	Conf. 3
Refrigerant	R134a	R134a	R134a
Application	LBP	LBP	LBP
System cooling	static	static	static
Hot gas defrost	- / -	- / -	- / -
Long interval pull down	- / -	- / -	- / -

Electrical data - Configurations with TLES5.7FT.3

	Conf. 1	Conf. 2	Conf. 3
Starting device type	PTC	relay	PTC
Run capacitor	- / -	- / -	4μF
Start capacitor	- / -	60μF	- / -
LRA (locked rotor amps / 4s)	5,4A	5,7A	5,4A
RLA (rated load amps / 1s)	1,1A	1,1A	1,1A
Cut in current	9,7A	9,7A	9,7A
IP class	21	21	21

Model

Designation

TLES5.7FT.3 220-240V/50Hz 1~

Sales code:

102G4615

Compressor dimensions

Housing	A Height	174mm / 6,85in
	B Height	170mm / 6,69in
	C Length shell	176mm / 6,93in
	D Length w. cover	222mm / 8,74in
	E Width	157mm / 6,18in

Connectors		Suction	Discharge	Process
		X	Y	Z
Diameter	[mm]	øi 6,11-6,29	øi 5,12-5,22	øi 6,11-6,29
(i:inside, o:outside)	[in]	øi 0,24-0,25	øi 0,2-0,21	øi 0,24-0,25
Material		steel/CU	steel/CU	steel/CU
Horizontal angle	±2°	0°	0°	0°
Vertical angle	±2°	150°	28°	31,5°
Position l/h/w	[mm]	-102/105/66	117/107/29	96/105/71
	[in]	-4/4,1/2,6	4,6/4,2/1,1	3,8/4,1/2,8
Straight tube l.	[mm]	12	12	12
	[in]	0,5	0,5	0,5

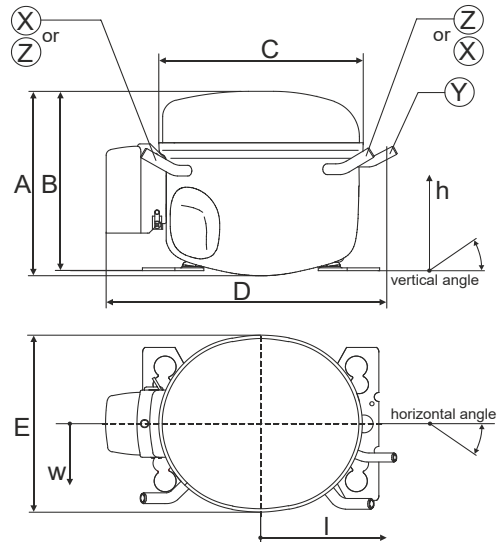

Compressor fixation

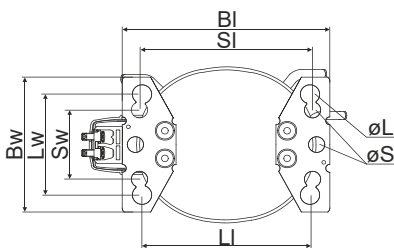

Baseplate	[mm]	[inch]
BI	204	8.03
Bw	136	5.35
Large holes		
LJ	165	6.5
Lw	101.6	4
øL	ø 19	ø 0.75
Small holes		
SI	170	6.7
Sw	70	2.76
øS	ø 16	ø 0.63

Bolt joint

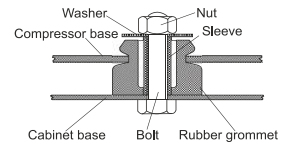

Snap-on

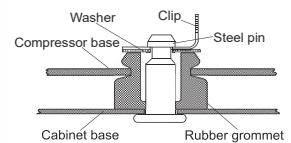

Mounting accessories

	one comp.	multi pack
Bolt joint M6 ø16mm	118-1917	118-1918
Bolt joint ø1/4" ø16mm	118-1946	
Bolt joint ø1/4" ø19mm	118-1949	
Snap-on ø7,3 ø16mm	118-1947	118-1919

Model

Designation **TLES5.7FT.3 220-240V/50Hz** Conf. 1 Sales code: **102G4615**

Configuration

Motorconfiguration RSIR
 Power supply (nominal) 220-240V/50Hz 1~
 Refrigerant R134a
 Application LBP
 Voltage range 187-254V
 Starting torque LST
 Approvals VDE
 EAC

Electrical accessories / wiring diagram

RSIR

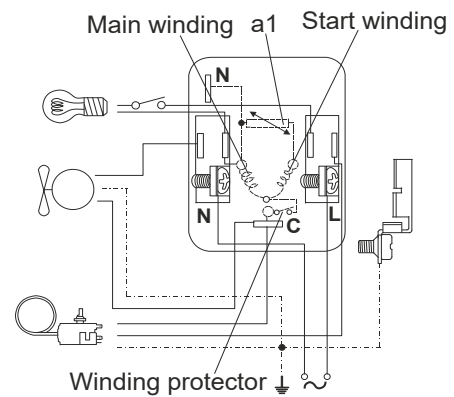
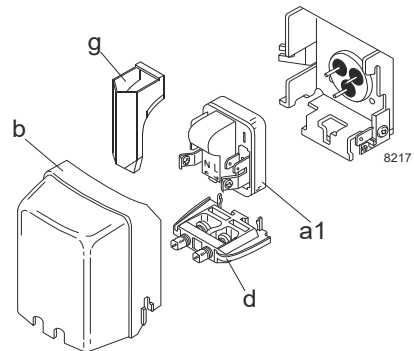

Ambient temperatures / system cooling

Ambient temperature min.: 10°C / 50°F
 Ambient temperature max.: 43°C / 110°F

System cooling (n/a: outside limits)			
T ambient	LBP	MBP	HBP
32°C / 90°F	static	n/a	n/a
38°C / 100°F	static	n/a	n/a
43°C / 110°F	static	n/a	n/a

Operation pressure range

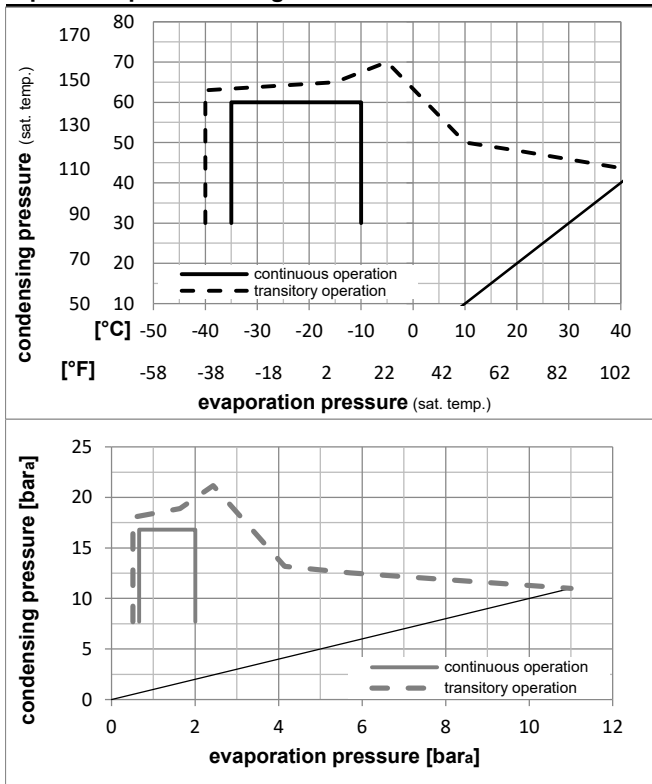

Components

- a1 PTC starter (220V, 250hm, 4.8mm) 103N0018
- b plastic cover 103N2010
- d cord relief 103N1010
- g protection screen for PTC 103N0476

Alternative components

- a1 PTC starter (220V, 250hm, 6.3mm) 103N0011
- b plastic cover 103N2011
- d cord relief 103N1010
- g protection screen for PTC 103N0476

Model

Designation **TLES5.7FT.3 220-240V/50Hz** Conf. 1 Sales code: **102G4615**

Optimization + standard conditions

220V/50Hz, RSIR, static, VDE, EAC

Evaporating pressure (saturation temperature)														
Condensing pressure (saturation temperature)														
Return gas temp.														
Liquid temp.														
Cooling capacity														
COP														
EER														
Power consumption														
Current consumption														
Ref. mass flow														
	pe	pc	RGT	Tliq	[W]	[Btu/h]	[kcal/h]	[W/W]	[Btu/Wh]	[kcal/Wh]	P1	I	m	
[°C]	[°C]	[°C]	[°C]	[°C]	[W]	[Btu/h]	[kcal/h]	[W/W]	[Btu/Wh]	[kcal/Wh]	[W]	[A]	[kg/h]	
[°F]	-23,3	54,4	32,2	32,2	162,5	555	139,8	1,30	4,45	1,12	124,8	0,97	3,16	ASHRAE LBP
[°F]	-10	130	90	90										
[°C]	-25	55	32	55	120,0	410	103,3	1,00	3,41	0,86	120,0	0,96	2,87	cecomaf LBP
[°F]	-13	131	89,6	131										
[°C]	-35	40	20	40	84,8	290	73,0	0,94	3,22	0,81	90,0	0,89	1,86	EN12900 LBP
[°F]	-31	104	68	104										
[°C]	-23,3	48,9	4,44	48,9	133,5	456	114,9	1,10	3,75	0,95	121,5	0,96	3,53	ARI540 LBP
[°F]	-10	120	40	120										
[°C]	-23,3	40,6	32,2	32,2	177,3	605	152,6	1,53	5,23	1,32	115,7	0,95	3,44	AHAM LBP
[°F]	-10	105	90	90										
[°C]	-35	45	32	45	80,4	275	69,2	0,88	3,02	0,76	90,9	0,89	1,73	opt
[°F]	-31	113	89,6	113										

Performance tables

220V/50Hz, RSIR, static, VDE, EAC

	pe	Cooling capacity			COP	EER	P1	I	m		
		[°C]	[°F]	[W]						[Btu/h]	[kcal/h]
[°C / °F]	-35	-31	80,4	275	69,2	0,88	3,02	0,76	90,9	0,89	1,73
cond. pressure	-30	-22	107,9	368	92,8	1,05	3,59	0,90	102,6	0,91	2,33
pc= 45/113	-25	-13	142,1	485	122,3	1,24	4,23	1,07	114,7	0,94	3,08
return gas temp.	-23,3	-10	155,4	531	133,7	1,31	4,46	1,12	119,0	0,95	3,37
RGT= 32/90	-20	-4	183,9	628	158,3	1,44	4,92	1,24	127,7	0,98	4,00
liquid temp	-15	5	234,3	800	201,6	1,65	5,63	1,42	142,1	1,03	5,11
Tliq= 45/113	-10	14	294,0	1004	253,0	1,86	6,34	1,60	158,3	1,09	6,43
[°C / °F]	-35	-31	66,3	227	57,1	0,74	2,52	0,63	90,0	0,89	1,58
cond. pressure	-30	-22	90,3	308	77,7	0,86	2,94	0,74	105,0	0,92	2,15
pc= 55/131	-25	-13	120,0	410	103,3	1,00	3,41	0,86	120,0	0,96	2,87
return gas temp	-23,3	-10	131,6	449	113,2	1,05	3,59	0,90	125,2	0,97	3,15
RGT= 32/90	-20	-4	156,4	534	134,6	1,15	3,94	0,99	135,6	1,00	3,75
liquid temp	-15	5	200,4	684	172,5	1,32	4,50	1,13	152,2	1,06	4,82
Tliq= 55/131	-10	14	252,8	863	217,6	1,48	5,07	1,28	170,4	1,13	6,11

Model

Designation **TLES5.7FT.3 220-240V/50Hz** Conf. 2 Sales code: **102G4615**

Configuration

Motorconfiguration CSIR
 Power supply (nominal) 220-240V/50Hz 1~
 Refrigerant R134a
 Application LBP
 Voltage range 187-254V
 Starting torque HST
 Approvals VDE
 EAC

Electrical accessories / wiring diagram

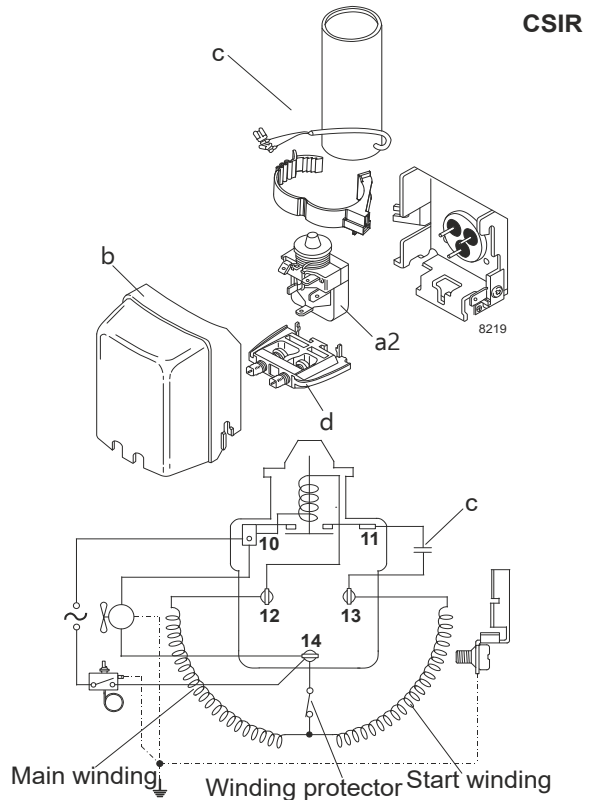

Ambient temperatures / system cooling

Ambient temperature min.: 10°C / 50°F
 Ambient temperature max.: 43°C / 110°F

System cooling (n/a: outside limits)			
T ambient	LBP	MBP	HBP
32°C / 90°F	static	n/a	n/a
38°C / 100°F	static	n/a	n/a
43°C / 110°F	static	n/a	n/a

Operation pressure range

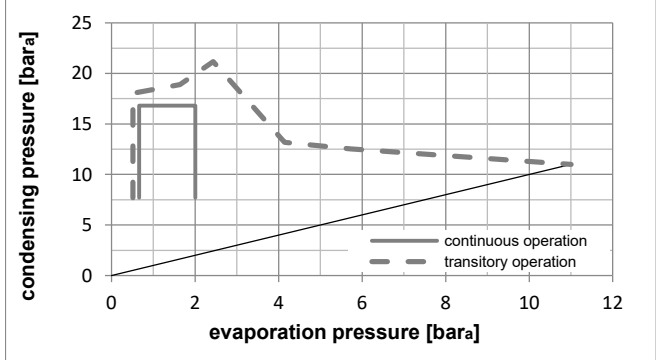
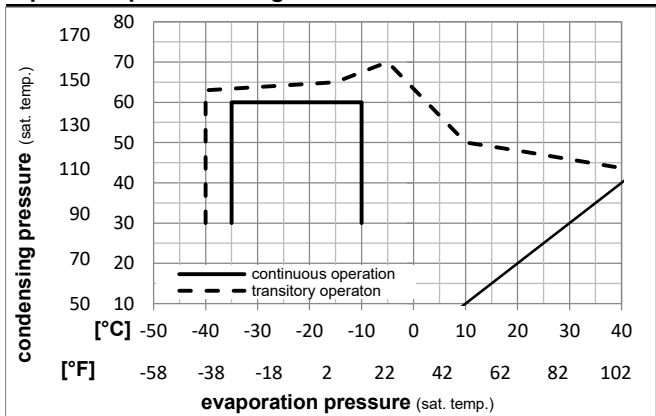

Components

- a2 current relay 117U6004
- c start capacitor (60µF) 117U5014
- d cord relief 103N1010
- b plastic cover 103N2011

Model

Designation **TLES5.7FT.3 220-240V/50Hz** Conf. **2** Sales code: **102G4615**

Optimization + standard conditions

220V/50Hz, CSIR, static, VDE, EAC

Evaporating pressure (saturation temperature)														
Condensing pressure (saturation temperature)														
Return gas temp.														
Liquid temp.														
Cooling capacity														
COP														
EER														
Power consumption														
Current consumption														
Ref. mass flow														
	pe	pc	RGT	Tliq	[W]	[Btu/h]	[kcal/h]	[W/W]	[Btu/Wh]	[kcal/Wh]	P1	I	m	
[°C]	[°C]	[°C]	[°C]	[°C]	[W]	[Btu/h]	[kcal/h]	[W/W]	[Btu/Wh]	[kcal/Wh]	[W]	[A]	[kg/h]	
[°F]	-23,3	54,4	32,2	32,2	162,5	555	139,8	1,30	4,45	1,12	124,8	0,97	3,16	ASHRAE LBP
[°F]	-10	130	90	90										
[°C]	-25	55	32	55	120,0	410	103,3	1,00	3,41	0,86	120,0	0,96	2,87	cecomaf LBP
[°F]	-13	131	89,6	131										
[°C]	-35	40	20	40	84,8	290	73,0	0,94	3,22	0,81	90,0	0,89	1,86	EN12900 LBP
[°F]	-31	104	68	104										
[°C]	-23,3	48,9	4,44	48,9	133,5	456	114,9	1,10	3,75	0,95	121,5	0,96	3,53	ARI540 LBP
[°F]	-10	120	40	120										
[°C]	-23,3	40,6	32,2	32,2	177,3	605	152,6	1,53	5,23	1,32	115,7	0,95	3,44	AHAM LBP
[°F]	-10	105	90	90										
[°C]	-35	45	32	45	80,4	275	69,2	0,88	3,02	0,76	90,9	0,89	1,73	opt
[°F]	-31	113	89,6	113										

Performance tables

220V/50Hz, CSIR, static, VDE, EAC

	pe	Cooling capacity			COP	EER	P1	I	m			
		[°C]	[°F]	[W]						[Btu/h]	[kcal/h]	[W/W]
[°C / °F]	-35	-31		80,4	275	69,2	0,88	3,02	0,76	90,9	0,89	1,73
cond. pressure	-30	-22		107,9	368	92,8	1,05	3,59	0,90	102,6	0,91	2,33
pc= 45/113	-25	-13		142,1	485	122,3	1,24	4,23	1,07	114,7	0,94	3,08
return gas temp.	-23,3	-10		155,4	531	133,7	1,31	4,46	1,12	119,0	0,95	3,37
RGT= 32/90	-20	-4		183,9	628	158,3	1,44	4,92	1,24	127,7	0,98	4,00
liquid temp	-15	5		234,3	800	201,6	1,65	5,63	1,42	142,1	1,03	5,11
Tliq= 45/113	-10	14		294,0	1004	253,0	1,86	6,34	1,60	158,3	1,09	6,43
[°C / °F]	-35	-31		66,3	227	57,1	0,74	2,52	0,63	90,0	0,89	1,58
cond. pressure	-30	-22		90,3	308	77,7	0,86	2,94	0,74	105,0	0,92	2,15
pc= 55/131	-25	-13		120,0	410	103,3	1,00	3,41	0,86	120,0	0,96	2,87
return gas temp	-23,3	-10		131,6	449	113,2	1,05	3,59	0,90	125,2	0,97	3,15
RGT= 32/90	-20	-4		156,4	534	134,6	1,15	3,94	0,99	135,6	1,00	3,75
liquid temp	-15	5		200,4	684	172,5	1,32	4,50	1,13	152,2	1,06	4,82
Tliq= 55/131	-10	14		252,8	863	217,6	1,48	5,07	1,28	170,4	1,13	6,11

Model

Designation **TLES5.7FT.3 220-240V/50Hz** Conf. 3 Sales code: **102G4615**

Configuration

Motorconfiguration RSCR
 Power supply (nominal) 220-240V/50Hz 1~
 Refrigerant R134a
 Application LBP
 Voltage range 187-254V
 Starting torque LST
 Approvals VDE
 EAC

Electrical accessories / wiring diagram

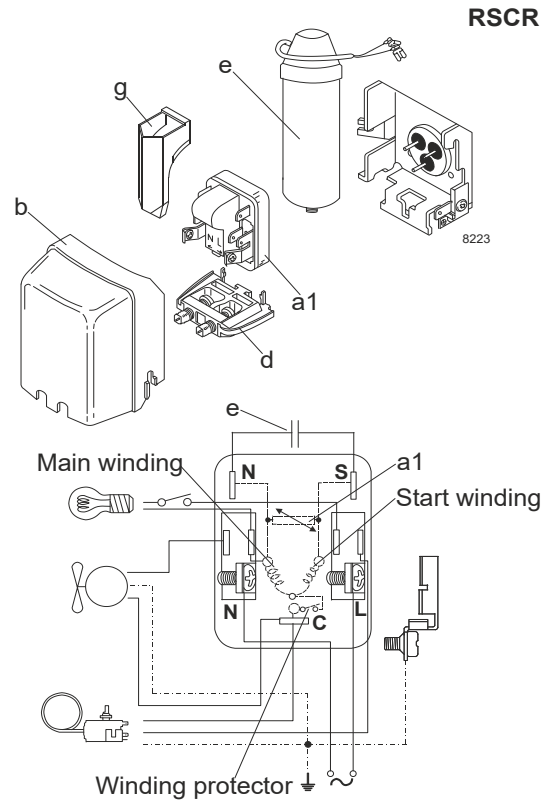

Ambient temperatures / system cooling

Ambient temperature min.: 10°C / 50°F
 Ambient temperature max.: 43°C / 110°F

System cooling (n/a: outside limits)			
T ambient	LBP	MBP	HBP
32°C / 90°F	static	n/a	n/a
38°C / 100°F	static	n/a	n/a
43°C / 110°F	static	n/a	n/a

Operation pressure range

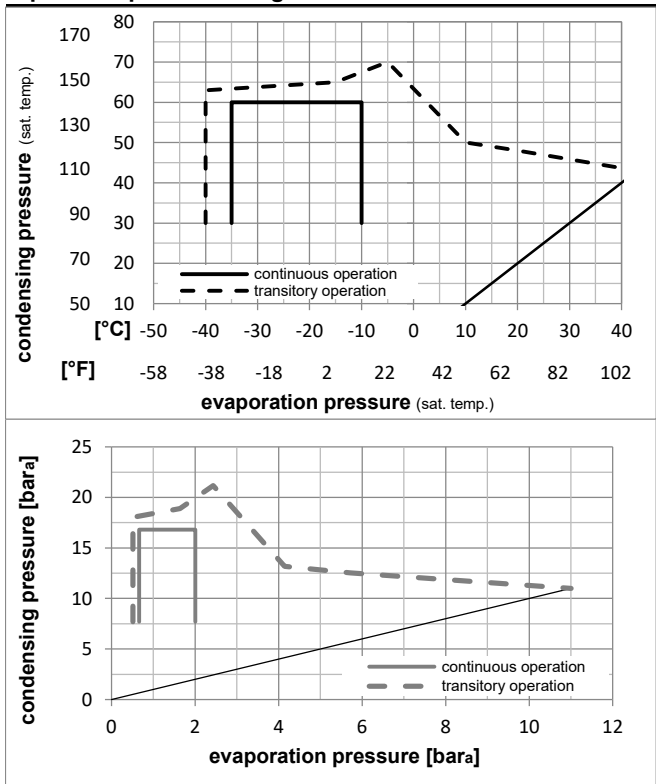

Components

- a1 PTC starter (220V, 250hm, 6.3mm) 103N0016
- b plastic cover 103N2010
- d cord relief 103N1010
- g protection screen for PTC 103N0476

Alternative components

- a1 PTC starter (220V, 250hm, 4.8mm) 103N0021
- b plastic cover 103N2011
- d cord relief 103N1010
- g protection screen for PTC 103N0476

Model

Designation **TLES5.7FT.3 220-240V/50Hz** Conf. **3** Sales code: **102G4615**

Optimization + standard conditions

220V/50Hz, RSCR, static, VDE, EAC

Evaporating pressure (saturation temperature)														
Condensing pressure (saturation temperature)														
Return gas temp.														
Liquid temp.														
Cooling capacity														
COP														
EER														
Power consumption														
Current consumption														
Ref. mass flow														
	pe	pc	RGT	Tliq	[W]	[Btu/h]	[kcal/h]	[W/W]	[Btu/Wh]	[kcal/Wh]	P1	I	m	
[°C]	[°C]	[°C]	[°C]	[°C]	[W]	[Btu/h]	[kcal/h]	[W/W]	[Btu/Wh]	[kcal/Wh]	[W]	[A]	[kg/h]	
[°F]	-23,3	54,4	32,2	32,2	162,5	555	139,8	1,35	4,62	1,16	120,1	0,71	3,16	ASHRAE LBP
[°F]	-10	130	90	90										
[°C]	-25	55	32	55	120,0	410	103,3	1,04	3,55	0,89	115,5	0,70	2,87	cecomaf LBP
[°F]	-13	131	89,6	131										
[°C]	-35	40	20	40	84,8	290	73,0	0,97	3,32	0,84	87,2	0,60	1,86	EN12900 LBP
[°F]	-31	104	68	104										
[°C]	-23,3	48,9	4,44	48,9	133,5	456	114,9	1,14	3,90	0,98	117,1	0,70	3,53	ARI540 LBP
[°F]	-10	120	40	120										
[°C]	-23,3	40,6	32,2	32,2	177,3	605	152,6	1,59	5,44	1,37	111,2	0,68	3,44	AHAM LBP
[°F]	-10	105	90	90										
[°C]	-35	45	32	45	80,4	275	69,2	0,91	3,10	0,78	88,6	0,61	1,73	opt
[°F]	-31	113	89,6	113										

Performance tables

220V/50Hz, RSCR, static, VDE, EAC

	pe	Cooling capacity			COP	EER	P1	I	m		
		[°C]	[°F]	[W]						[Btu/h]	[kcal/h]
[°C / °F]	-35	-31	80,4	275	69,2	0,91	3,10	0,78	88,6	0,61	1,73
cond. pressure	-30	-22	107,9	368	92,8	1,09	3,71	0,94	99,2	0,64	2,33
pc= 45/113	-25	-13	142,1	485	122,3	1,29	4,39	1,11	110,5	0,68	3,08
return gas temp.	-23,3	-10	155,4	531	133,7	1,36	4,63	1,17	114,6	0,69	3,37
RGT= 32/90	-20	-4	183,9	628	158,3	1,50	5,11	1,29	122,8	0,72	4,00
liquid temp	-15	5	234,3	800	201,6	1,72	5,87	1,48	136,4	0,78	5,11
Tliq= 45/113	-10	14	294,0	1004	253,0	1,94	6,63	1,67	151,4	0,84	6,43
[°C / °F]	-35	-31	66,3	227	57,1	0,76	2,59	0,65	87,6	0,61	1,58
cond. pressure	-30	-22	90,3	308	77,7	0,89	3,04	0,77	101,3	0,65	2,15
pc= 55/131	-25	-13	120,0	410	103,3	1,04	3,55	0,89	115,5	0,70	2,87
return gas temp	-23,3	-10	131,6	449	113,2	1,09	3,73	0,94	120,4	0,71	3,15
RGT= 32/90	-20	-4	156,4	534	134,6	1,20	4,10	1,03	130,2	0,75	3,75
liquid temp	-15	5	200,4	684	172,5	1,37	4,69	1,18	145,9	0,82	4,82
Tliq= 55/131	-10	14	252,8	863	217,6	1,55	5,31	1,34	162,7	0,89	6,11

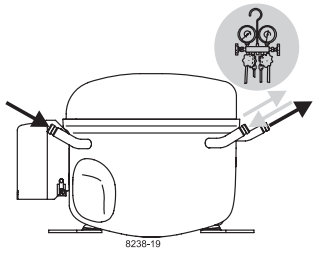

TL Compressors

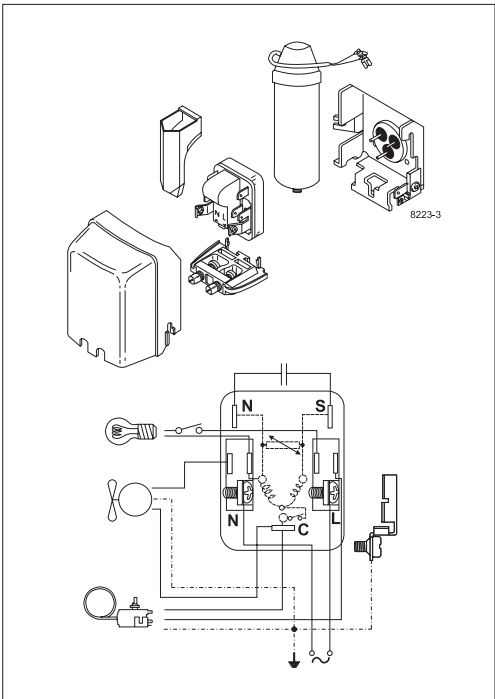
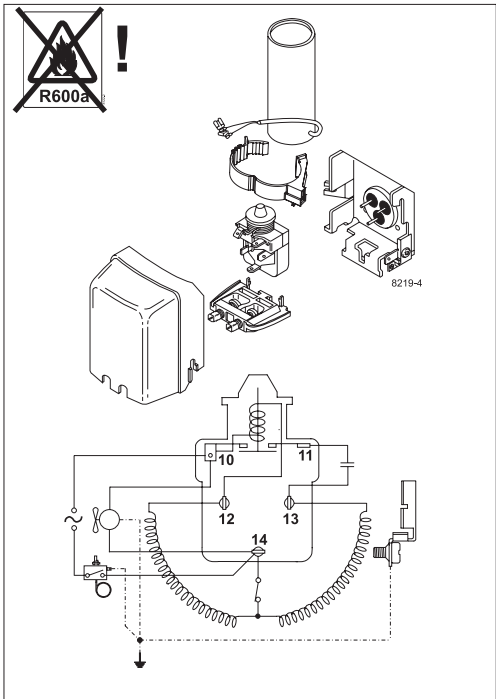
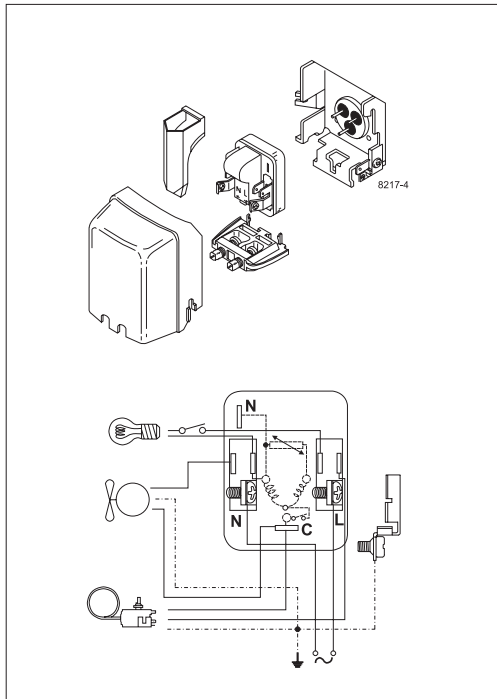

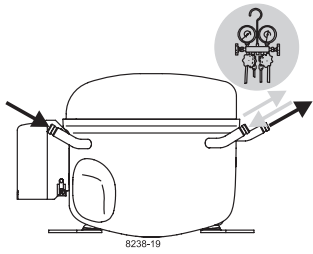

Service/Repair – R600a, R290

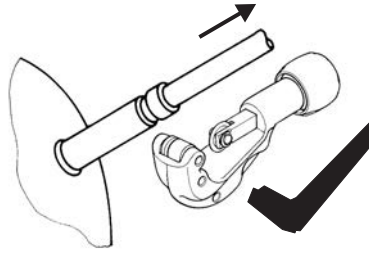
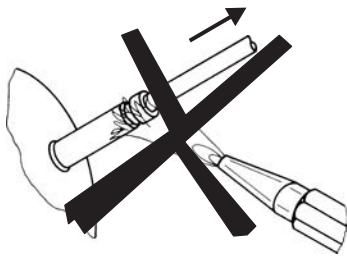

8545

Brazing on Suction Connectors (Direct Intake)

representative image

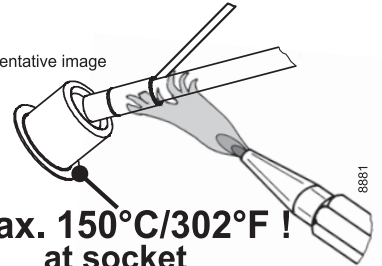

**! max. 150°C/302°F !
at socket**

brazing solder: phosphor (LP7) or silver

Refer to Product Bulletin:
**Brazing on Suction Connectors
(Compressors with Direct Suction Intake)**

Secop accepts no responsibility for possible errors in catalogs, brochures, and other printed material. Secop reserves the right to alter its products without notice. This also applies to products already on order provided that such alterations can be made without subsequential changes being necessary to specifications already agreed. All trademarks in this material are the property of the respective companies. Secop and the Secop logotype are trademarks of Secop GmbH. All rights reserved. www.secop.com