

## Single Pack FRK11G 220-240V 50Hz / 208-230V 60Hz CSIR

Single pack code number: **195B4772**

Position	Title	Code	Amount
1	Compressor FRK11G	106G5953	1
2	Starting capacitor (80 $\mu$ F 220V, 6.3mm)	117U5001	1
3	Starting relay (QLZ-5.5A, overload protector T0377/L6)	117U7071	1
4	KL accessories	103N1060	1
5	Bolt joint for one compressor   M6   $\varnothing$ 16mm	118-1917	1

Secop GmbH • Lise-Meitner-Straße 29 • 24941 Flensburg, Germany • Tel: +49 461 4941 0 • [www.secop.com](http://www.secop.com)

Secop accepts no responsibility for possible errors in catalogs, brochures, and other printed material. Secop reserves the right to alter its products without notice. This also applies to products already on order provided that such alterations can be made without subsequent changes being necessary to specifications already agreed. All trademarks in this material are the property of the respective companies. Secop and the Secop logotype are trademarks of Secop GmbH. All rights reserved.

## Model

Designation	<b>FRK11G</b>	<b>220-240V/50Hz 1~ 208-230V/60Hz 1~</b>	Sales code:	<b>106G5953</b>
-------------	---------------	--	-------------	-----------------

## Compressor design

Oil type	Polyolester	Refrigerant(s)	<b>R134a, R513A</b>
Oil viscosity	19,2cSt	Displacement	8,6cm <sup>3</sup> / 0,52cu.in
Oil quantity	240cm <sup>3</sup> / 8,1fl.oz	Compressors on pallet	100
Refr. charge - tech. limit	700g / 24,7oz		
Free gas volume comp.	1495cm <sup>3</sup> / 50,6fl.oz		
Weight	9,7kg / 21,4lbs		
Motor protection	external		
Winding resistance main	8,4Ω (at 25°C)		
Winding resistance aux	11,9Ω (at 25°C)		
Max. winding temp.	125°C / 257°F		
Max. discharge temp.	130°C / 266°F		
Additional note	Very good robustness against liquid intake. Ice-cube maker optimization - indirect suction intake. Special design for high refrigerant charge		



## General - Configurations with FRK11G

	<b>Conf. 1</b>	<b>Conf. 2</b>
Motorconfiguration	CSIR	CSIR
Power supply (nominal)	220-240V/50Hz	208-230V/60Hz
Number of phases	1	1
Voltage range	187-254V	198-253V
Approvals	VDE, (UL,CB) in progress	VDE, (UL,CB) in progress
Starting torque	HST	HST
Note	- / -	

## Applications with FRK11G

	<b>Conf. 1</b>	<b>Conf. 2</b>
Refrigerant	R134a	R134a
Application	LBP+MBP+HBP	LBP+MBP
System cooling	fan 3m/s	fan 3m/s
Hot gas defrost	OK	OK
Long interval pull down	OK	OK

## Electrical data - Configurations with FRK11G

	<b>Conf. 1</b>	<b>Conf. 2</b>
Starting device type	relay	relay
Run capacitor	-/-	-/-
Start capacitor	80μF	80μF
LRA (locked rotor amps / 4s/ U(N))	13,5A	13,5A
RLA (rated load amps / 1s/ U(N))	2,1A	2,1A
Cut in current (U(N))	12,3A	12,3A

## Model

Designation	<b>FRK11G</b>	220-240V/50Hz 1~ 208-230V/60Hz 1~	Sales code:	<b>106G5953</b>
-------------	---------------	-----------------------------------	-------------	-----------------

## Compressor dimensions

<b>Housing</b>	A Height	182mm / 7,17in
	B Height	175mm / 6,89in
	C Length shell	198mm / 7,8in
	D Length w. cover	238mm / 9,37in
	E Width	160mm / 6,3in

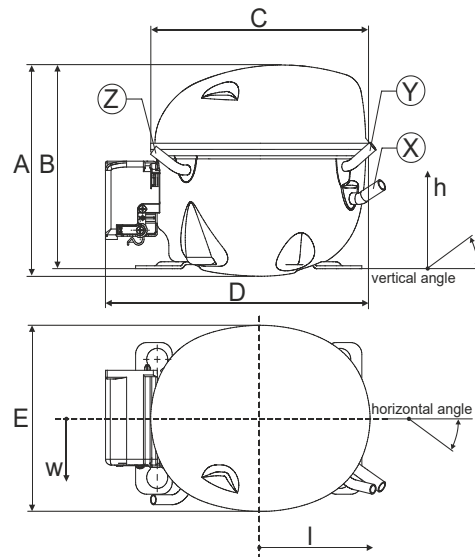

Connectors		Suction	Discharge	Process
		X	Y	Z
Diameter	[mm]	øi 8,11-8,29	øi 6,11-6,29	øi 6,11-6,29
(i:inside, o:outside)	[in]	øi 0,32-0,33	øi 0,24-0,25	øi 0,24-0,25
Material		copper	copper	copper
Horizontal angle	±2°	35°	13°	0°
Vertical angle	±2°	30°	40°	145°
Position l/h/w	[mm]	119/73/59	117/107/66	-88/101/71
	[in]	4,7/2,9/2,3	4,6/4,2/2,6	-3,5/4/2,8
Straight tube l.	[mm]	14	14	14
	[in]	0,5	0,5	0,5

## Compressor fixation

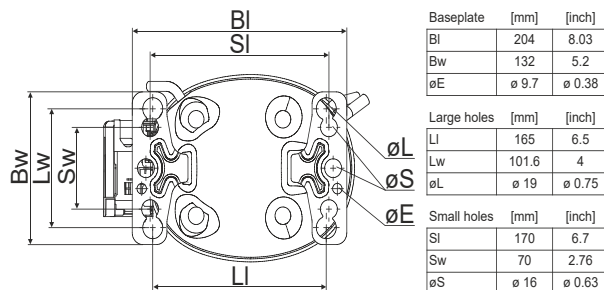

### Bolt joint

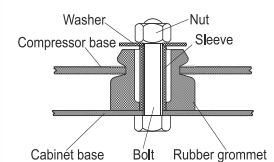

### Snap-on

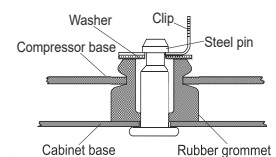

Mounting accessories	one comp.	multi pack
Bolt joint   M6   ø16mm	118-1917	118-1918
Bolt joint   ø1/4"   ø16mm	118-1946	
Bolt joint   ø1/4"   ø19mm	118-1949	
Snap-on   ø7,3   ø16mm	118-1947	118-1919

## Application notes

Provision for PE Grounding is located at the PE Stamp on the compressor

Suctiongas connector and Process connector can be switched (minor loss of cooling capacity)

## Model

Designation	<b>FRK11G</b>	<b>220-240V/50Hz</b>	Conf. 1	Sales code:	<b>106G5953</b>
-------------	---------------	----------------------	---------	-------------	-----------------

## Configuration

Motorconfiguration	CSIR
Power supply (nominal)	220-240V/50Hz 1~
Refrigerant	R134a
Application	LBP+MBP+HBP
Voltage range	187-254V
Starting torque	HST
Approvals	VDE
	(UL,CB) in progress

## Electrical accessories / wiring diagram

CSIR

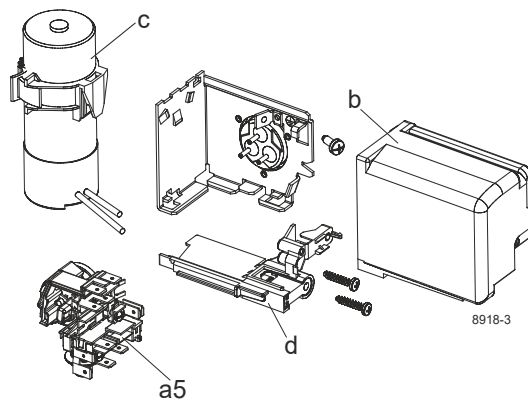

## Ambient/ machine room temperatures minimum /maximum

Ambient temperature range: 10 - 43°C / 50 - 110°F

Machine room temperature range: 10 - 48°C / 50 - 119°F

Compressor cooling: fan 3m/s

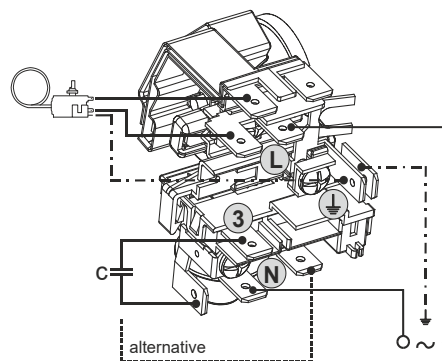

## Operation pressure range

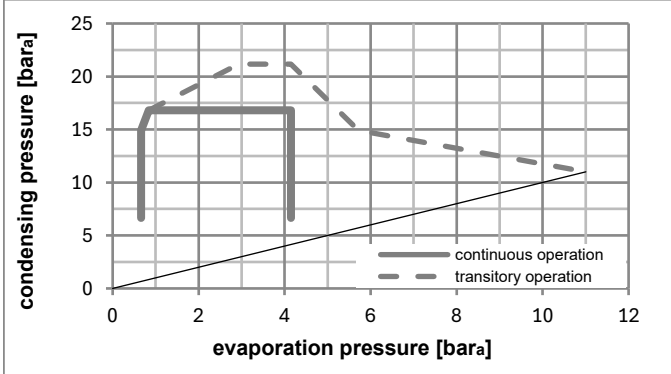
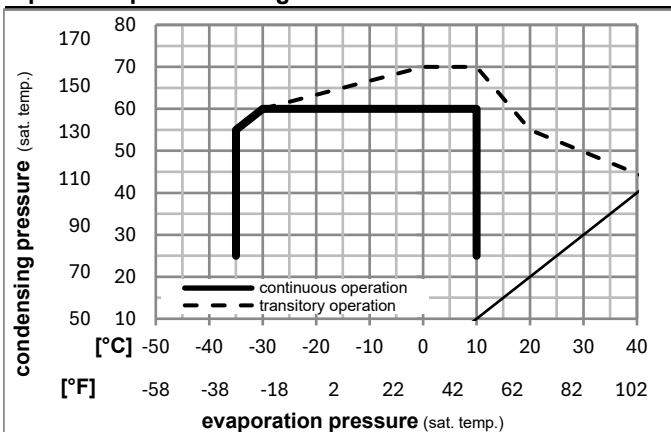

## Components

a5	current relay (T0377/L6-S1)	117U7071
c	start capacitor (80µF, 6.3mm)	117U5001
b, d	cover + clamp + screws(5VA-compl.)	103N0600

## Alternative components

b, d	100x cover + clamp + screws(5VA)	103N2060
b, d	cover + clamp + screws(5VA) in bag	103N1060

### Model

Designation **FRK11G** **220-240V/50Hz** Conf. 1 Sales code: **106G5953**

### Optimization + standard conditions

R134a, 220V/50Hz, CSIR, fan 3m/s, VDE, (UL,CB) in progress

	Evaporating pressure (saturation temperature)				Cooling capacity			COP	EER		Power consumption			ASHRAE LBP
	pe	pc	RGT	Tliq	[W]	[Btu/h]	[kcal/h]		[W/W]	[Btu/Wh]	[kcal/Wh]	P1	I	
[°C]	-23	54	32	32	239,6	818	206,2	1,32	4,52	1,14	180,9	1,39	4,65	
[°F]	-10	130	90	90										
[°C]	-7	54	35	46	495,5	1692	426,5	1,80	6,13	1,55	276,0	1,76	10,81	ASHRAE MBP
[°F]	20	130	95	115										
[°C]	7,2	54	35	46	866,5	2959	745,7	2,43	8,29	2,09	357,0	2,12	19,22	ASHRAE HBP
[°F]	45	130	95	115										
[°C]	-35	40	20	40	123,5	422	106,3	0,91	3,09	0,78	136,3	1,27	2,71	EN12900 LBP
[°F]	-31	104	68	104										
[°C]	-10	45	20	45	430,9	1472	370,8	1,79	6,10	1,54	241,4	1,62	10,09	EN12900 MBP
[°F]	14	113	68	113										
[°C]	5	50	20	50	741,9	2534	638,5	2,25	7,68	1,93	330,0	1,99	18,69	EN12900 HBP
[°F]	41	122	68	122										

### Performance tables

R134a, 220V/50Hz, CSIR, fan 3m/s, VDE, (UL,CB) in progress

	pe		Cooling capacity			COP	EER		P1	I	m
	[°C]	[°F]	[W]	[Btu/h]	[kcal/h]		[W/W]	[Btu/Wh]			
[°C / °F]	-35	-31	117,5	401	101,1	0,87	2,97	0,75	135,3	1,26	2,54
cond. pressure	-25	-13	207,3	708	178,4	1,21	4,14	1,04	171,2	1,36	4,49
pc= 45/113	-15	5	352,0	1202	303,0	1,62	5,55	1,40	216,8	1,52	7,67
return gas temp.	-10	14	447,0	1527	384,7	1,85	6,32	1,59	241,4	1,62	9,78
RGT= 32/90	0	32	686,7	2345	591,0	2,37	8,08	2,04	290,3	1,82	15,19
liquid temp	5	41	833,0	2845	716,9	2,66	9,09	2,29	313,1	1,92	18,54
Tliq= 45/113	10	50	998,1	3409	858,9	2,99	10,21	2,57	333,8	2,01	22,40
[°C / °F]	-35	-31	95,3	326	82,0	0,73	2,51	0,63	129,8	1,25	2,27
cond. pressure	-25	-13	176,0	601	151,4	1,02	3,48	0,88	172,8	1,37	4,21
pc= 55/131	-15	5	302,4	1033	260,2	1,33	4,54	1,14	227,3	1,56	7,28
return gas temp	-10	14	384,8	1314	331,2	1,50	5,11	1,29	257,0	1,68	9,31
RGT= 32/90	0	32	592,6	2024	510,0	1,87	6,38	1,61	317,4	1,94	14,49
liquid temp	5	41	719,5	2457	619,2	2,08	7,09	1,79	346,6	2,07	17,73
Tliq= 55/131	10	50	863,0	2947	742,7	2,31	7,88	1,99	374,1	2,19	21,45

## Model

Designation	<b>FRK11G</b>	<b>208-230V/60Hz</b>	<b>Conf. 2</b>	Sales code:	<b>106G5953</b>
-------------	---------------	----------------------	----------------	-------------	-----------------

## Configuration

Motorconfiguration	CSIR
Power supply (nominal)	208-230V/60Hz 1~
Refrigerant	R134a
Application	LBP+MBP
Voltage range	198-253V
Starting torque	HST
Approvals	VDE (UL,CB) in progress

## Electrical accessories / wiring diagram

CSIR

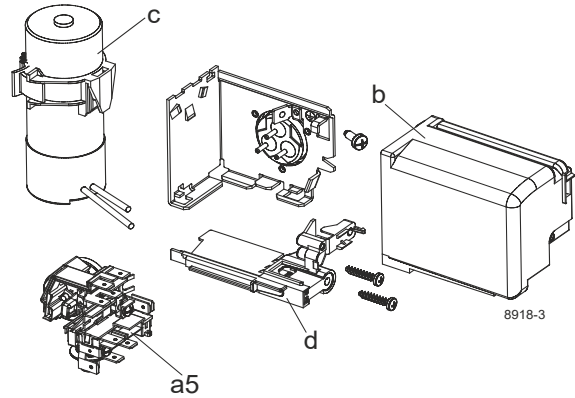

## Ambient/ machine room temperatures minimum /maximum

Ambient temperature range:	10 - 43°C / 50 - 110°F
Machine room temperature range:	10 - 48°C / 50 - 119°F
Compressor cooling:	fan 3m/s

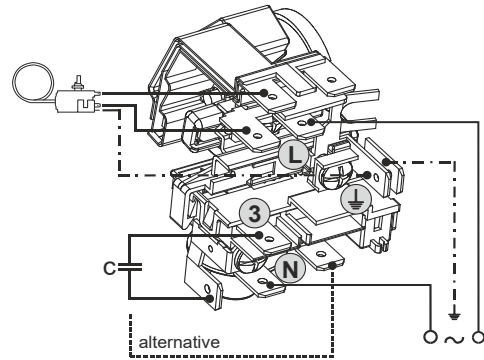

## Operation pressure range

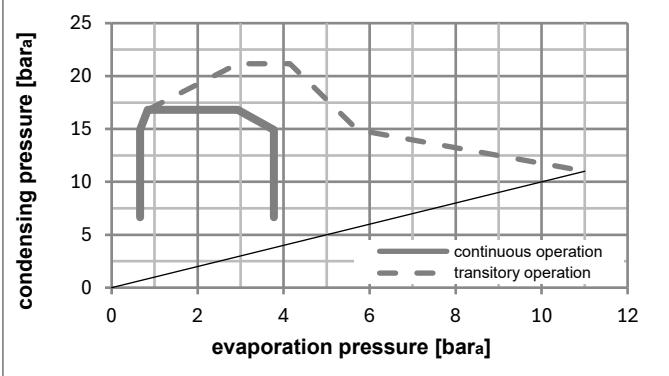
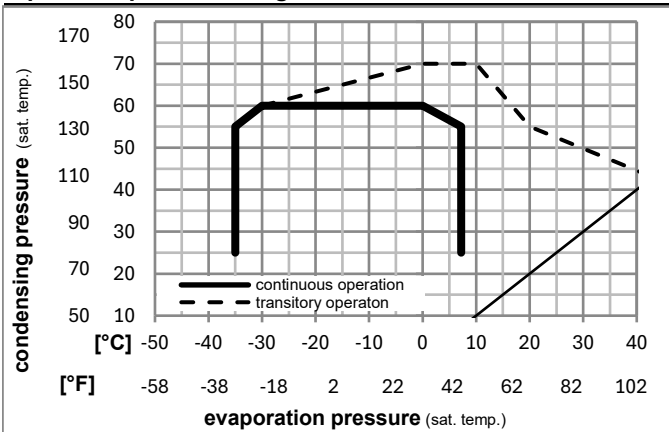

## Components

a5	current relay (T0377/L6-S1)	117U7071
c	start capacitor (80µF, 6.3mm)	117U5001
b, d	cover + clamp + screws(5VA-compl.)	103N0600

## Alternative components

b, d	100x cover + clamp + screws(5VA)	103N2060
b, d	cover + clamp + screws(5VA) in bag	103N1060

### Model

Designation **FRK11G** **208-230V/60Hz** Conf. 2 Sales code: **106G5953**

### Optimization + standard conditions

R134a, 230V/60Hz, CSIR, fan 3m/s, VDE, (UL,CB) in progress

	Evaporating pressure (saturation temperature)				Cooling capacity			COP	EER	P1	Power consumption		ASHRAE	
	pe	pc	RGT	Tliq	[W]	[Btu/h]	[kcal/h]				I	m		
	[°C]	[°F]	[°C]	[°F]	[W]	[Btu/h]	[kcal/h]	[W/W]	[Btu/Wh]	[kcal/Wh]	[W]	[A]	[kg/h]	
	-23	54	32	32	286,0	977	246,1	1,34	4,59	1,16	212,7	1,38	5,55	ASHRAE LBP
	-10	130	90	90										
	-7	54	35	46	590,8	2018	508,5	1,79	6,10	1,54	331,0	1,80	12,89	ASHRAE MBP
	20	130	95	115										
	7,2	54	35	46	1031,9	3524	888,0	2,34	7,98	2,01	441,4	2,25	22,89	ASHRAE HBP
	45	130	95	115										
	-35	40	20	40	149,2	510	128,4	1,11	3,81	0,96	133,9	1,16	3,27	EN12900 LBP
	-31	104	68	104										
	-10	45	20	45	514,0	1756	442,4	1,81	6,17	1,55	284,7	1,62	12,03	EN12900 MBP
	14	113	68	113										
	5	50	20	50	884,1	3019	760,8	2,20	7,52	1,90	401,3	2,08	22,28	EN12900 HBP
	41	122	68	122										

### Performance tables

R134a, 230V/60Hz, CSIR, fan 3m/s, VDE, (UL,CB) in progress

	pe		Cooling capacity			COP	EER	P1	I	m	
	[°C]	[°F]	[W]	[Btu/h]	[kcal/h]						
[°C / °F]	-35	-31	141,0	482	121,3	1,05	3,58	0,90	134,6	1,16	3,04
cond. pressure	-25	-13	248,1	847	213,5	1,27	4,33	1,09	195,7	1,33	5,37
pc= 45/113	-15	5	420,2	1435	361,7	1,65	5,62	1,42	255,2	1,52	9,16
return gas temp.	-10	14	533,3	1821	459,0	1,87	6,40	1,61	284,7	1,62	11,67
RGT= 32/90	-5	23	665,8	2274	573,0	2,12	7,23	1,82	314,4	1,73	14,64
liquid temp	0	32	818,7	2796	704,6	2,38	8,12	2,05	344,4	1,85	18,11
Tliq= 45/113	7,2	45	1077,0	3678	926,9	2,77	9,47	2,39	388,5	2,03	24,06
[°C / °F]	-35	-31	112,6	385	96,9	0,83	2,82	0,71	136,2	1,16	2,68
cond. pressure	-25	-13	210,0	717	180,7	1,04	3,55	0,90	201,9	1,35	5,02
pc= 55/131	-15	5	360,9	1233	310,6	1,33	4,55	1,15	271,1	1,58	8,69
return gas temp	-10	14	459,1	1568	395,1	1,49	5,10	1,29	307,4	1,71	11,10
RGT= 32/90	-5	23	573,7	1959	493,8	1,66	5,68	1,43	345,1	1,85	13,95
liquid temp	0	32	706,0	2411	607,6	1,84	6,27	1,58	384,4	2,01	17,27
Tliq= 55/131	7,2	45	929,4	3174	799,9	2,09	7,15	1,80	444,2	2,26	22,99



# KL Compressors

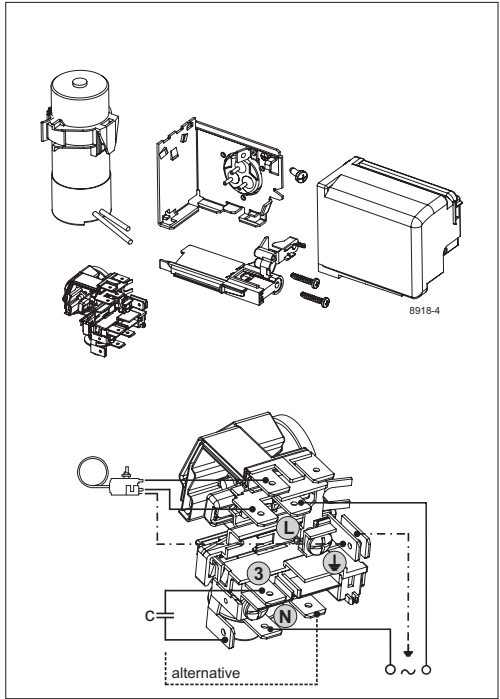



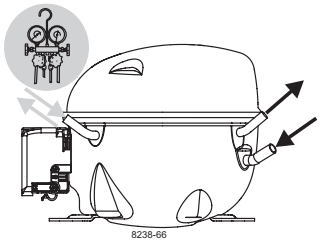

# KL Compressors



## Service/Repair – R290

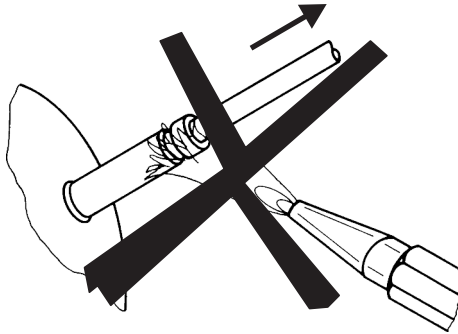

8545

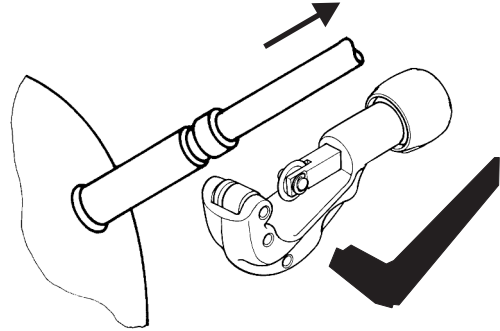

Secop accepts no responsibility for possible errors in catalogs, brochures, and other printed material. Secop reserves the right to alter its products without notice. This also applies to products already on order provided that such alterations can be made without subsequent changes being necessary to specifications already agreed. All trademarks in this material are the property of the respective companies. Secop and the Secop logotype are trademarks of Secop GmbH. All rights reserved. [www.secop.com](http://www.secop.com)