

Single Pack KLF6.6CNT 200-240V 50Hz / 208-230V 60Hz CSIR

Single pack code number: **195B4778**

Position	Title	Code	Amount
1	Compressor KLF6.6CNT	106H2702	1
2	KL accessories	103N1060	1
3	Starting capacitor (80 μ F 260V, 6.3mm)	117U5003	1
4	Starting relay (QLZ-4.4A, overload protector T1218/L6)	117U7077	1
5	Bolt joint for one compressor M6 \varnothing 16mm	118-1917	1

Secop GmbH • Lise-Meitner-Straße 29 • 24941 Flensburg, Germany • Tel: +49 461 4941 0 • www.secop.com

Secop accepts no responsibility for possible errors in catalogs, brochures, and other printed material. Secop reserves the right to alter its products without notice. This also applies to products already on order provided that such alterations can be made without subsequent changes being necessary to specifications already agreed. All trademarks in this material are the property of the respective companies. Secop and the Secop logotype are trademarks of Secop GmbH. All rights reserved.

Model

Designation	KLF6.6CNT	200-240V/50Hz 1~	208-230V/60Hz 1~	Sales code:	106H2702
-------------	------------------	-------------------------	-------------------------	-------------	-----------------

Compressor design

Oil type	Polyolester	Refrigerant(s)	R290
Oil viscosity	19,2cSt	Displacement	6,6cm ³ / 0,4cu.in
Oil quantity	170cm ³ / 5,7fl.oz	Compressors on pallet	100
Refr. charge - tech. limit	200g / 7,1oz		
Free gas volume comp.	1583cm ³ / 53,5fl.oz		
Weight	9,5kg / 20,9lbs		
Motor protection	external		
Winding resistance main	8,4Ω (at 25°C)		
Winding resistance aux	11,9Ω (at 25°C)		
Max. winding temp.	125°C / 257°F		
Max. discharge temp.	130°C / 266°F		



General - Configurations with KLF6.6CNT

	Conf. 1	Conf. 2	Conf. 3	Conf. 4
Motorconfiguration	CSIR	RSCR	CSIR	RSCR
Power supply (nominal)	200-240V/50Hz	200-240V/50Hz	208-230V/60Hz	208-230V/60Hz
Number of phases	1	1	1	1
Voltage range	187-254V	187-254V	198-253V	198-253V
Approvals	UL, KC	UL, KC	UL, KC	UL, KC
Starting torque	HST	LST	HST	LST
Note	- / -			

Applications with KLF6.6CNT

	Conf. 1	Conf. 2	Conf. 3	Conf. 4
Refrigerant	R290	R290	R290	R290
Application	LBP+MBP	LBP+MBP	LBP+MBP	LBP+MBP
System cooling	fan 3m/s	fan 3m/s	fan 3m/s	fan 3m/s
Hot gas defrost	OK	OK	OK	OK
Long interval pull down	OK	OK	OK	OK

Electrical data - Configurations with KLF6.6CNT

	Conf. 1	Conf. 2	Conf. 3	Conf. 4
Starting device type	relay	PTC	relay	PTC
Run capacitor	-/-	5μF	-/-	5μF
Start capacitor	80μF	-/-	80μF	-/-
LRA (locked rotor amps / 4s/ U(N))	13,5A	13,5A	12,9A	12,9A
RLA (rated load amps / 1s/ U(N))	1,8A	1,8A	1,7A	1,7A
Cut in current (U(N))	12,3A	18,1A		

Model

Designation **KLF6.6CNT** 200-240V/50Hz 1~ 208-230V/60Hz 1~ Sales code: **106H2702**

Compressor dimensions

Housing	A Height	182mm / 7,17in
	B Height	175mm / 6,89in
	C Length shell	198mm / 7,8in
	D Length w. cover	238mm / 9,37in
	E Width	160mm / 6,3in

Connectors	Suction	Discharge	Process
	X	Y	Z
Diameter [mm]	øi 8,11-8,29	øi 6,11-6,29	øi 6,11-6,29
(i:inside, o:outside) [in]	øi 0,32-0,33	øi 0,24-0,25	øi 0,24-0,25
Material	copper	copper	copper
Horizontal angle ±2°	35°	13°	0°
Vertical angle ±2°	30°	40°	145°
Position l/h/w [mm]	119/73/59	117/107/66	-88/101/71
[in]	4,7/2,9/2,3	4,6/4,2/2,6	-3,5/4/2,8
Straight tube l. [mm]	14	14	14
[in]	0,5	0,5	0,5

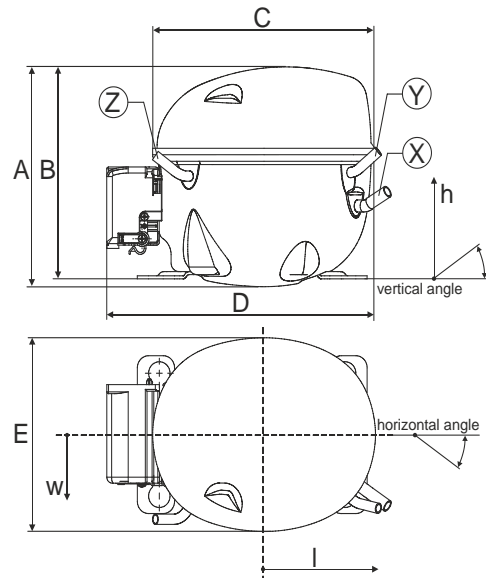

Compressor fixation

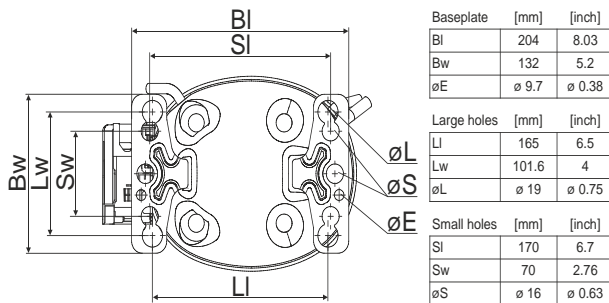

Bolt joint

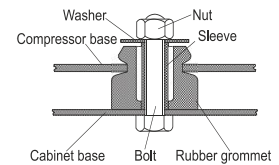

Snap-on

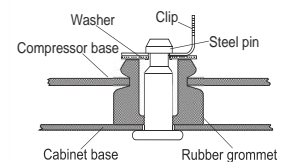

Mounting accessories	one comp.	multi pack
Bolt joint M6 ø16mm	118-1917	118-1918
Bolt joint ø1/4" ø16mm	118-1946	
Bolt joint ø1/4" ø19mm	118-1949	
Snap-on ø7,3 ø16mm	118-1947	118-1919

Application notes

Provision for PE Grounding is located at the PE Stamp on the compressor

Model

Designation	KLF6.6CNT	200-240V/50Hz	Conf. 1	Sales code:	106H2702
-------------	------------------	----------------------	----------------	-------------	-----------------

Configuration

Motorconfiguration	CSIR
Power supply (nominal)	200-240V/50Hz 1~
Refrigerant	R290
Application	LBP+MBP
Voltage range	187-254V
Starting torque	HST
Approvals	UL KC

Electrical accessories / wiring diagram

CSIR

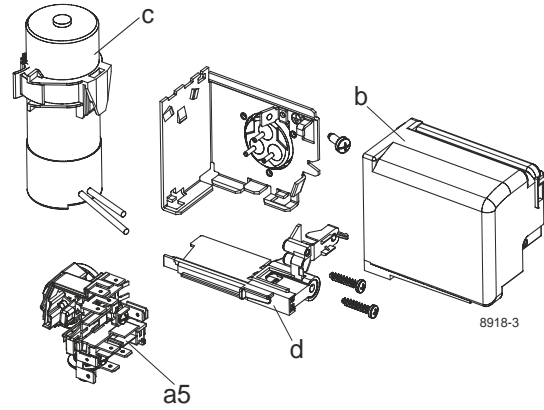

Ambient/ machine room temperatures minimum /maximum

Ambient temperature range:	10 - 43°C / 50 - 110°F
Machine room temperature range:	10 - 48°C / 50 - 119°F
Compressor cooling:	fan 3m/s

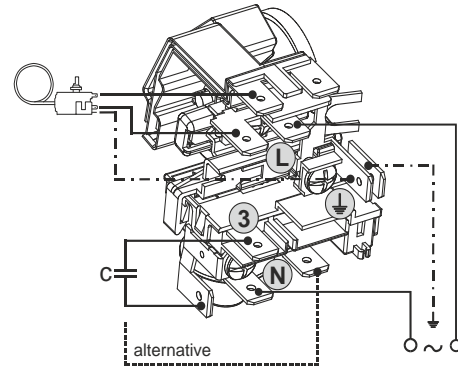

Operation pressure range

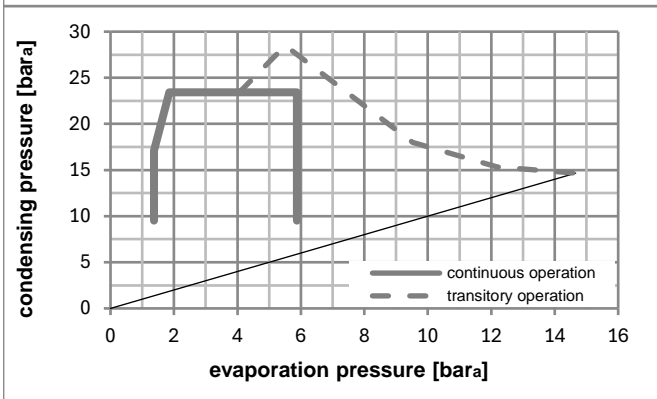
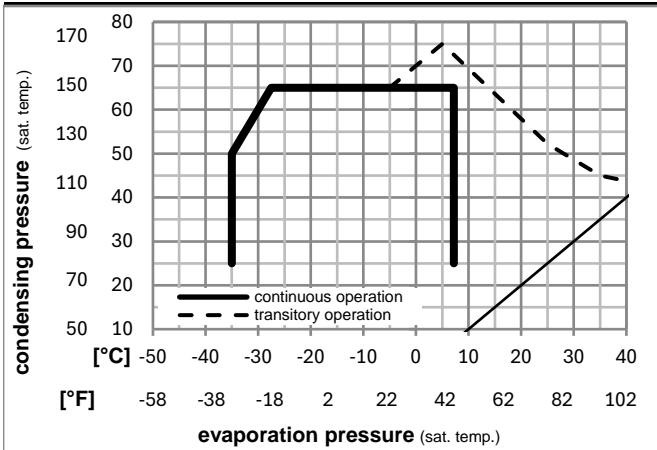

Components

a5	current relay (T0377/L6-S1)	117U7071
c	start capacitor (80µF, 6.3mm)	117U5003
b, d	cover + clamp + screws(5VA-compl.)	103N0600

Alternative components

b, d	100x cover + clamp + screws(5VA)	103N2060
b, d	cover + clamp + screws(5VA) in bag	103N1060

Model

Designation **KLF6.6CNT** **200-240V/50Hz** Conf. 1 Sales code: **106H2702**

Optimization + standard conditions

R290, 220V/50Hz, CSIR, fan 3m/s, UL, KC

		Evaporating pressure (saturation temperature)				Condensing pressure (saturation temperature)			Return gas temp.		Liquid temp.		Cooling capacity			COP	EER	Power consumption			Ref. mass flow
		pe	pc	RGT	Tliq	[W]	[Btu/h]	[kcal/h]	[W/W]	[Btu/Wh]	[kcal/Wh]	P1	I	m	[W]	[A]	[kg/h]				
[°C]	-23	54	32	32	333,5	1139	287,0	1,47	5,01	1,26	227,4	1,60	3,38	ASHRAE LBP							
[°F]	-10	130	90	90																	
[°C]	-25	55	32	55	249,5	852	214,7	1,14	3,88	0,98	219,4	1,58	3,11	cecomaf LBP							
[°F]	-13	131	90	131																	
[°C]	-35	40	20	40	178,5	610	153,6	1,20	4,08	1,03	149,4	1,42	2,04	EN12900 LBP							
[°F]	-31	104	68	104																	
[°C]	-7	54	35	46	585,1	1998	503,6	1,93	6,59	1,66	303,1	1,85	6,67	ASHRAE MBP							
[°F]	20	130	95	115																	
[°C]	-10	55	32	55	467,8	1598	402,6	1,60	5,47	1,38	291,9	1,81	5,92	cecomaf MBP							
[°F]	14	131	90	131																	
[°C]	-10	45	20	45	516,0	1762	444,1	2,00	6,84	1,72	257,6	1,69	6,34	EN12900 MBP							
[°F]	14	113	68	113																	

Performance tables

R290, 220V/50Hz, CSIR, fan 3m/s, UL, KC

	pe		Cooling capacity			COP	EER		P1	I	m
	[°C]	[°F]	[W]	[Btu/h]	[kcal/h]	[W/W]	[Btu/Wh]	[kcal/Wh]	[W]	[A]	[kg/h]
[°C / °F]	-25	-13	295,1	1008	254,0	1,45	4,95	1,25	203,8	1,53	3,33
cond. pressure	-25	-13	295,1	1008	254,0	1,45	4,95	1,25	203,8	1,53	3,33
pc= 45/113	-15	5	446,0	1523	383,8	1,84	6,30	1,59	241,8	1,64	5,07
return gas temp.	-10	14	537,2	1835	462,3	2,09	7,12	1,79	257,6	1,69	6,15
RGT= 32/90	-5	23	640,7	2188	551,4	2,37	8,08	2,04	270,7	1,73	7,38
liquid temp	0	32	757,8	2588	652,1	2,70	9,21	2,32	281,0	1,77	8,79
Tliq= 45/113	7,2	45	952,7	3254	819,9	3,28	11,21	2,82	290,3	1,80	11,19
[°C / °F]	-25	-13	249,5	852	214,7	1,14	3,88	0,98	219,4	1,58	3,11
cond. pressure	-25	-13	249,5	852	214,7	1,14	3,88	0,98	219,4	1,58	3,11
pc= 55/131	-15	5	385,8	1318	332,0	1,43	4,89	1,23	269,5	1,73	4,85
return gas temp	-10	14	467,8	1598	402,6	1,60	5,47	1,38	291,9	1,81	5,92
RGT= 32/90	-5	23	560,8	1915	482,7	1,80	6,14	1,55	312,0	1,88	7,14
liquid temp	0	32	666,1	2275	573,2	2,02	6,90	1,74	329,7	1,94	8,56
Tliq= 55/131	7,2	45	841,7	2875	724,4	2,40	8,21	2,07	350,3	2,02	10,97

Model

Designation **KLF6.6CNT** **200-240V/50Hz** Conf. 2 Sales code: **106H2702**

Configuration

Motorconfiguration RSCR
 Power supply (nominal) 200-240V/50Hz 1~
 Refrigerant R290
 Application LBP+MBP
 Voltage range 187-254V
 Starting torque LST
 Approvals UL
 KC

Electrical accessories / wiring diagram

RSCR

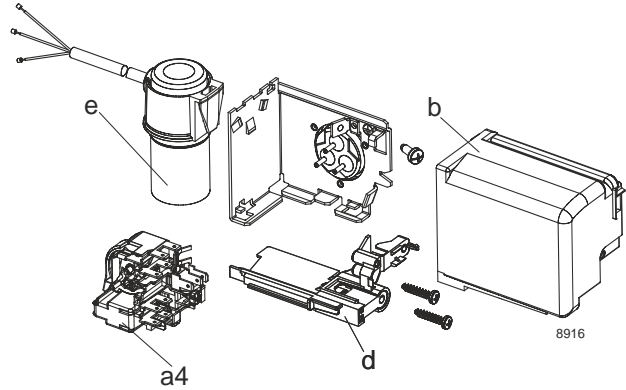

Ambient/ machine room temperatures minimum /maximum

Ambient temperature range: 10 - 43°C / 50 - 110°F

Machine room temperature range: 10 - 48°C / 50 - 119°F

Compressor cooling: fan 3m/s

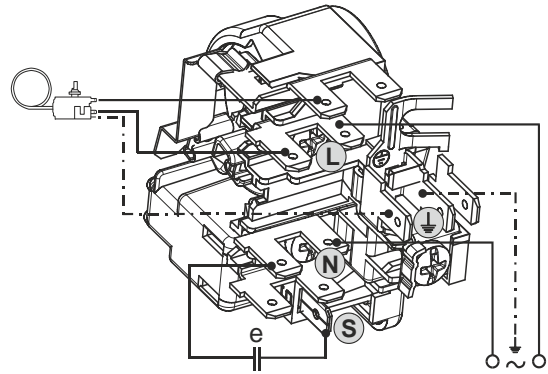

Operation pressure range

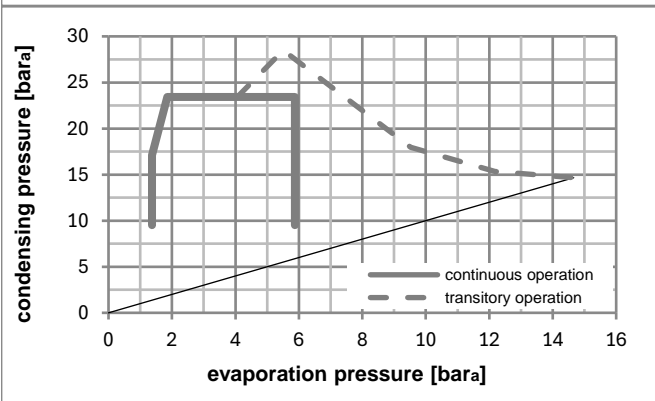
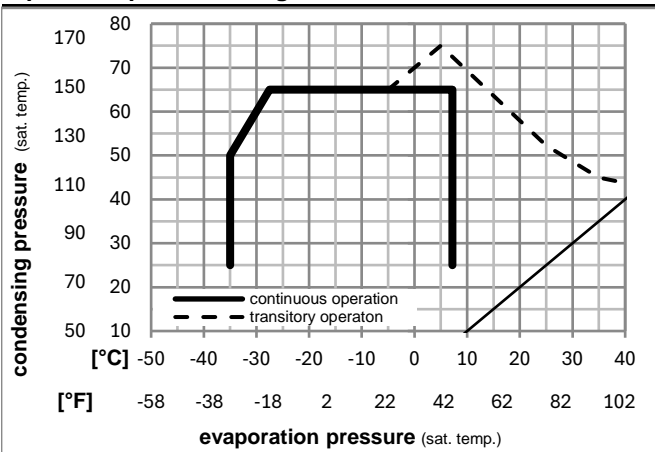

Components

a4	DAS1 (PTC,6.3mm, T0377/L6 - S1)	103N0250
e	run capacitor (5μF, 6.3mm)	117-7191
b, d	cover + clamp + screws(5VA-compl.)	103N0600

Alternative components

a4	ZAS1 (PTC,4.8mm, T0377/L6 - S1)	103N0252
e	run capacitor (5μF, 4.8mm)	117-7190

b, d	100x cover + clamp + screws(5VA)	103N2060
b, d	cover + clamp + screws(5VA) in bag	103N1060

Model

 Designation **KLF6.6CNT** **200-240V/50Hz** Conf. 2 Sales code: **106H2702**
Optimization + standard conditions

R290, 220V/50Hz, RSCR, fan 3m/s, UL, KC

	Evaporating pressure (saturation temperature)				Condensing pressure (saturation temperature)			Return gas temp.			Liquid temp.			Cooling capacity			COP	EER	Power consumption			Ref. mass flow	ASHRAE LBP
	pe	pc	RGT	Tliq	[W]	[Btu/h]	[kcal/h]	[W/W]	[Btu/Wh]	[kcal/Wh]	P1	I	m										
[°C]	[°C]	[°C]	[°C]	[W]	[Btu/h]	[kcal/h]	[W/W]	[Btu/Wh]	[kcal/Wh]	[W]	[A]	[kg/h]											
[°C]	-23	54	32	32	336,8	1150	289,9	1,53	5,22	1,31	220,6	1,43	3,41	ASHRAE LBP									
[°F]	-10	130	90	90																			
[°C]	-25	55	32	55	252,0	861	216,9	1,18	4,04	1,02	212,8	1,41	3,14	cecomaf LBP									
[°F]	-13	131	90	131																			
[°C]	-35	40	20	40	180,3	616	155,2	1,24	4,25	1,07	144,9	1,25	2,06	EN12900 LBP									
[°F]	-31	104	68	104																			
[°C]	-7	54	35	46	591,0	2018	508,6	2,01	6,86	1,73	294,0	1,68	6,74	ASHRAE MBP									
[°F]	20	130	95	115																			
[°C]	-10	55	32	55	472,5	1614	406,6	1,67	5,70	1,44	283,1	1,64	5,98	cecomaf MBP									
[°F]	14	131	90	131																			
[°C]	-10	45	20	45	521,2	1780	448,5	2,09	7,12	1,80	249,9	1,52	6,40	EN12900 MBP									
[°F]	14	113	68	113																			

Performance tables

R290, 220V/50Hz, RSCR, fan 3m/s, UL, KC

	pe		Cooling capacity			COP	EER	P1	I	m	
	[°C]	[°F]	[W]	[Btu/h]	[kcal/h]	[W/W]	[Btu/Wh]	[kcal/Wh]	[W]	[A]	[kg/h]
[°C / °F]	-35	-31	179,7	614	154,6	1,17	3,98	1,00	154,0	1,27	2,01
cond. pressure	-25	-13	298,0	1018	256,5	1,51	5,15	1,30	197,6	1,36	3,36
pc= 45/113	-15	5	450,4	1538	387,6	1,92	6,56	1,65	234,6	1,47	5,12
return gas temp.	-10	14	542,6	1853	467,0	2,17	7,42	1,87	249,9	1,52	6,21
RGT= 32/90	-5	23	647,1	2210	556,9	2,46	8,42	2,12	262,6	1,56	7,45
liquid temp	0	32	765,4	2614	658,7	2,81	9,59	2,42	272,6	1,60	8,88
Tliq= 45/113	7,2	45	962,2	3286	828,1	3,42	11,67	2,94	281,6	1,63	11,30
[°C / °F]	-35	-31	143,1	489	123,1	0,90	3,07	0,77	159,1	1,26	1,77
cond. pressure	-25	-13	252,0	861	216,9	1,18	4,04	1,02	212,8	1,41	3,14
pc= 55/131	-15	5	389,7	1331	335,3	1,49	5,09	1,28	261,4	1,56	4,90
return gas temp	-10	14	472,5	1614	406,6	1,67	5,70	1,44	283,1	1,64	5,98
RGT= 32/90	-5	23	566,4	1934	487,5	1,87	6,39	1,61	302,7	1,71	7,22
liquid temp	0	32	672,7	2298	579,0	2,10	7,18	1,81	319,8	1,77	8,64
Tliq= 55/131	7,2	45	850,1	2903	731,6	2,50	8,54	2,15	339,8	1,85	11,08

Model

Designation **KLF6.6CNT** **208-230V/60Hz** Conf. 3 Sales code: **106H2702**

Configuration

Motorconfiguration CSIR
 Power supply (nominal) 208-230V/60Hz 1~
 Refrigerant R290
 Application LBP+MBP
 Voltage range 198-253V
 Starting torque HST
 Approvals UL
 KC

Electrical accessories / wiring diagram

CSIR

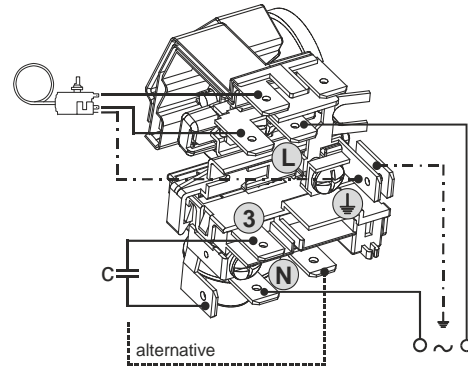
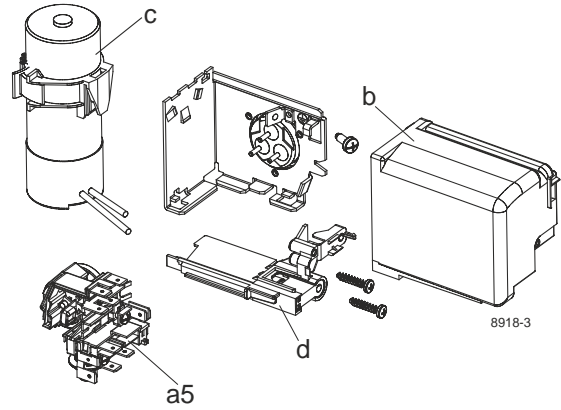

Ambient/ machine room temperatures minimum /maximum

Ambient temperature range: 10 - 43°C / 50 - 110°F

Machine room temperature range: 10 - 48°C / 50 - 119°F

Compressor cooling: fan 3m/s

Operation pressure range

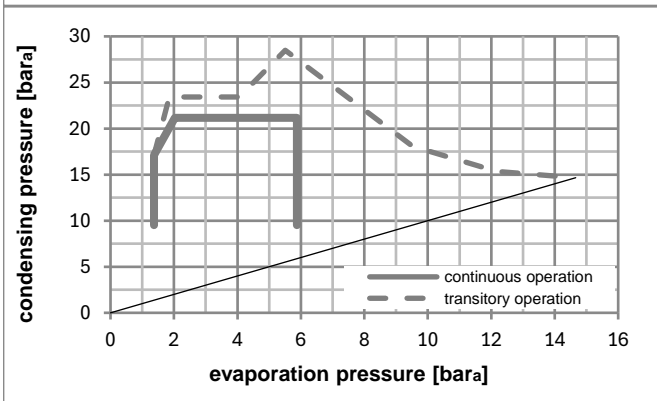
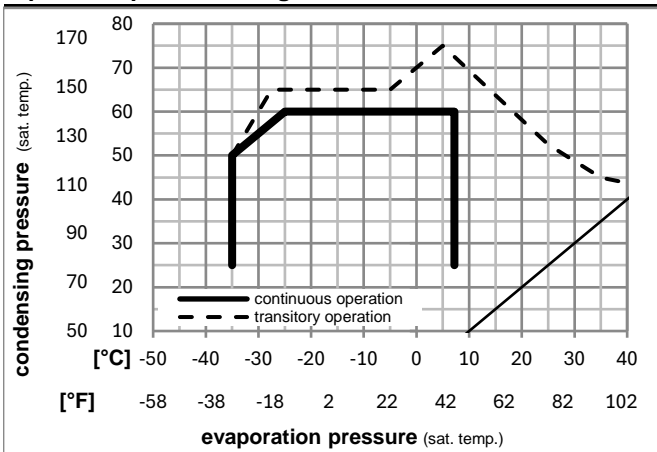

Components

a5	current relay (T0377/L6-S1)	117U7071
c	start capacitor (80µF, 6.3mm)	117U5003
b, d	cover + clamp + screws(5VA-compl.)	103N0600

Alternative components

b, d	100x cover + clamp + screws(5VA)	103N2060
b, d	cover + clamp + screws(5VA) in bag	103N1060

Model

Designation **KLF6.6CNT** **208-230V/60Hz** Conf. 3 Sales code: **106H2702**

Optimization + standard conditions

R290, 220V/60Hz, CSIR, fan 3m/s, UL, KC

	Evaporating pressure (saturation temperature)				Condensing pressure (saturation temperature)			COP	EER	Power consumption			ASHRAE LBP	
	pe	pc	RGT	Tliq	[W]	[Btu/h]	[kcal/h]			P1	I	Ref. mass flow		
	[°C]	[°F]	[°C]	[°C]	[W]	[Btu/h]	[kcal/h]	[W/W]	[Btu/Wh]	[kcal/Wh]	[W]	[A]	[kg/h]	
	-23	54	32	32	407,6	1392	350,7	1,56	5,32	1,34	261,8	1,71	4,13	ASHRAE LBP
	-10	130	90	90										
	-25	55	32	55	306,2	1046	263,5	1,22	4,16	1,05	251,6	1,68	3,81	cecomaf LBP
	-13	131	90	131										
	-35	40	20	40	216,8	740	186,6	1,21	4,15	1,05	178,5	1,49	2,48	EN12900 LBP
	-31	104	68	104										
	-7	54	35	46	702,4	2399	604,5	1,99	6,79	1,71	353,1	2,01	8,01	ASHRAE MBP
	20	130	95	115										
	-10	55	32	55	561,8	1919	483,5	1,66	5,67	1,43	338,3	1,96	7,11	cecomaf MBP
	14	131	90	131										
	-10	45	20	45	615,1	2101	529,4	2,01	6,86	1,73	306,3	1,85	7,55	EN12900 MBP
	14	113	68	113										

Performance tables

R290, 220V/60Hz, CSIR, fan 3m/s, UL, KC

	pe		Cooling capacity			COP	EER		P1	I	m
	[°C]	[°F]	[W]	[Btu/h]	[kcal/h]	[W/W]	[Btu/Wh]	[kcal/Wh]	[W]	[A]	[kg/h]
[°C / °F]	-35	-31	210,0	717	180,7	1,13	3,87	0,98	185,3	1,51	2,35
cond. pressure	-25	-13	352,5	1204	303,4	1,46	4,98	1,26	241,6	1,65	3,98
pc= 45/113	-15	5	531,5	1815	457,4	1,85	6,32	1,59	287,3	1,78	6,05
return gas temp.	-10	14	640,4	2187	551,1	2,09	7,14	1,80	306,3	1,85	7,33
RGT= 32/90	-5	23	765,2	2613	658,5	2,37	8,09	2,04	322,9	1,90	8,81
liquid temp	0	32	908,2	3102	781,6	2,69	9,20	2,32	337,1	1,95	10,53
Tliq= 45/113	7,2	45	1150,8	3930	990,4	3,26	11,12	2,80	353,5	2,01	13,52
[°C / °F]	-35	-31	176,9	604	152,2	0,96	3,29	0,83	183,6	1,49	2,19
cond. pressure	-25	-13	306,2	1046	263,5	1,22	4,16	1,05	251,6	1,68	3,81
pc= 55/131	-15	5	465,3	1589	400,5	1,49	5,10	1,29	311,3	1,87	5,85
return gas temp	-10	14	561,8	1919	483,5	1,66	5,67	1,43	338,3	1,96	7,11
RGT= 32/90	-5	23	672,6	2297	578,8	1,85	6,32	1,59	363,4	2,05	8,57
liquid temp	0	32	799,9	2732	688,4	2,07	7,06	1,78	386,7	2,13	10,27
Tliq= 55/131	7,2	45	1017,0	3473	875,2	2,44	8,32	2,10	417,3	2,25	13,25

Model

Designation	KLF6.6CNT	208-230V/60Hz	Conf. 4	Sales code:	106H2702
-------------	------------------	----------------------	----------------	-------------	-----------------

Configuration

Motorconfiguration	RSCR
Power supply (nominal)	208-230V/60Hz 1~
Refrigerant	R290
Application	LBP+MBP
Voltage range	198-253V
Starting torque	LST
Approvals	UL KC

Electrical accessories / wiring diagram

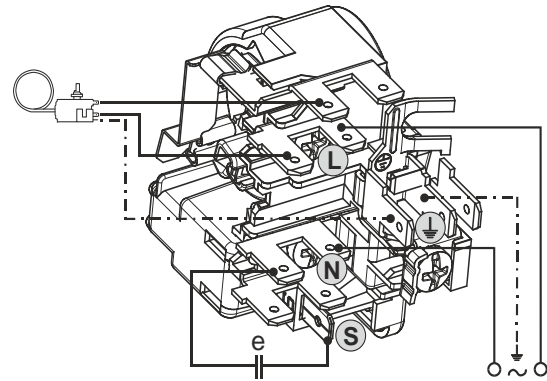
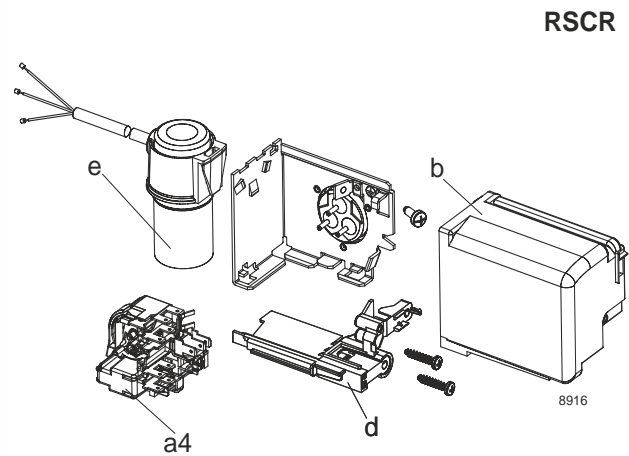

Ambient/ machine room temperatures minimum /maximum

Ambient temperature range:	10 - 43°C / 50 - 110°F
Machine room temperature range:	10 - 48°C / 50 - 119°F
Compressor cooling:	fan 3m/s

Operation pressure range

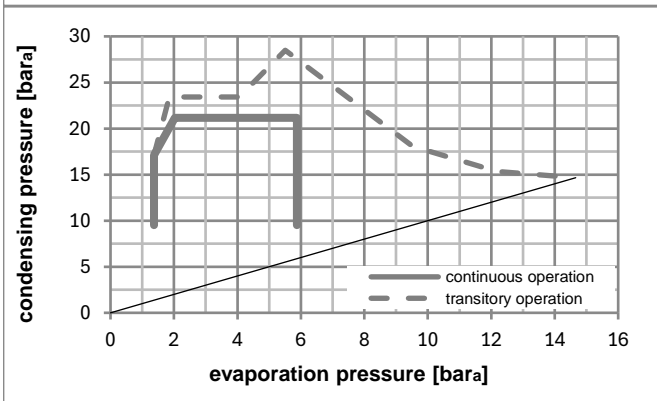
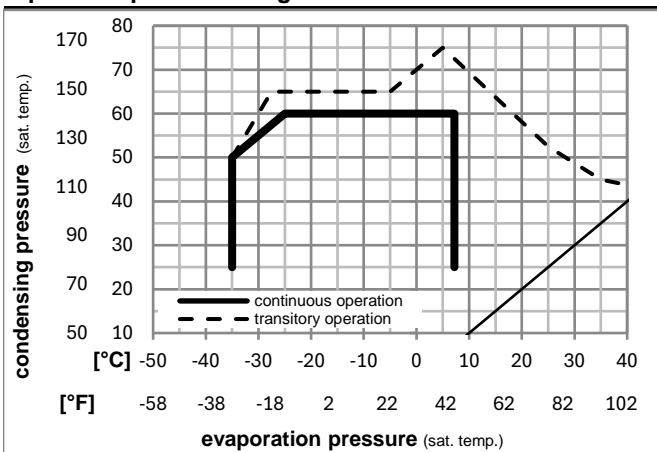

Components

a4	DAS1 (PTC,6.3mm, T0377/L6 - S1)	103N0250
e	run capacitor (5µF, 6.3mm)	117-7191
b, d	cover + clamp + screws(5VA-compl.)	103N0600

Alternative components

a4	ZAS1 (PTC,4.8mm, T0377/L6 - S1)	103N0252
e	run capacitor (5µF, 4.8mm)	117-7190

b, d	100x cover + clamp + screws(5VA)	103N2060
b, d	cover + clamp + screws(5VA) in bag	103N1060

Model

Designation **KLF6.6CNT** **208-230V/60Hz** Conf. 4 Sales code: **106H2702**

Optimization + standard conditions

R290, 220V/60Hz, RSCR, fan 3m/s, UL, KC

	Evaporating pressure (saturation temperature)				Condensing pressure (saturation temperature)			COP	EER	Power consumption			ASHRAE LBP	
	pe	pc	RGT	Tliq	[W]	[Btu/h]	[kcal/h]			P1	I	Ref. mass flow		
	[°C]	[°F]	[°C]	[°C]	[W]	[Btu/h]	[kcal/h]	[W/W]	[Btu/Wh]	[kcal/Wh]	[W]	[A]	[kg/h]	
	-23	54	32	32	411,6	1406	354,3	1,63	5,58	1,41	251,8	1,56	4,17	ASHRAE LBP
	-10	130	90	90										
	-25	55	32	55	309,2	1056	266,1	1,28	4,36	1,10	242,0	1,53	3,85	cecomaf LBP
	-13	131	90	131										
	-35	40	20	40	219,0	748	188,4	1,27	4,35	1,10	171,7	1,34	2,50	EN12900 LBP
	-31	104	68	104										
	-7	54	35	46	709,4	2423	610,5	2,09	7,13	1,80	339,7	1,86	8,09	ASHRAE MBP
	20	130	95	115										
	-10	55	32	55	567,4	1938	488,3	1,74	5,96	1,50	325,4	1,81	7,18	cecomaf MBP
	14	131	90	131										
	-10	45	20	45	621,3	2122	534,7	2,11	7,20	1,81	294,7	1,70	7,63	EN12900 MBP
	14	113	68	113										

Performance tables

R290, 220V/60Hz, RSCR, fan 3m/s, UL, KC

	pe		Cooling capacity			COP	EER	P1	I	m	
	[°C]	[°F]	[W]	[Btu/h]	[kcal/h]	[W/W]	[Btu/Wh]	[kcal/Wh]	[W]	[A]	[kg/h]
[°C / °F]	-35	-31	212,1	724	182,5	1,19	4,06	1,02	178,3	1,36	2,38
cond. pressure	-25	-13	356,0	1216	306,4	1,53	5,23	1,32	232,4	1,50	4,02
pc= 45/113	-15	5	536,8	1833	462,0	1,94	6,63	1,67	276,4	1,63	6,11
return gas temp.	-10	14	646,8	2209	556,6	2,20	7,50	1,89	294,7	1,70	7,40
RGT= 32/90	-5	23	772,8	2639	665,1	2,49	8,50	2,14	310,6	1,75	8,90
liquid temp	0	32	917,3	3133	789,4	2,83	9,66	2,43	324,3	1,80	10,64
Tliq= 45/113	7,2	45	1162,3	3970	1000,3	3,42	11,67	2,94	340,1	1,86	13,66
[°C / °F]	-35	-31	178,7	610	153,8	1,01	3,45	0,87	176,7	1,34	2,21
cond. pressure	-25	-13	309,2	1056	266,1	1,28	4,36	1,10	242,0	1,53	3,85
pc= 55/131	-15	5	470,0	1605	404,5	1,57	5,36	1,35	299,5	1,72	5,91
return gas temp	-10	14	567,4	1938	488,3	1,74	5,96	1,50	325,4	1,81	7,18
RGT= 32/90	-5	23	679,3	2320	584,6	1,94	6,64	1,67	349,5	1,90	8,65
liquid temp	0	32	807,9	2759	695,3	2,17	7,42	1,87	372,0	1,98	10,38
Tliq= 55/131	7,2	45	1027,2	3508	884,0	2,56	8,74	2,20	401,5	2,10	13,38

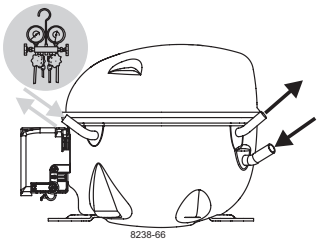

KL Compressors

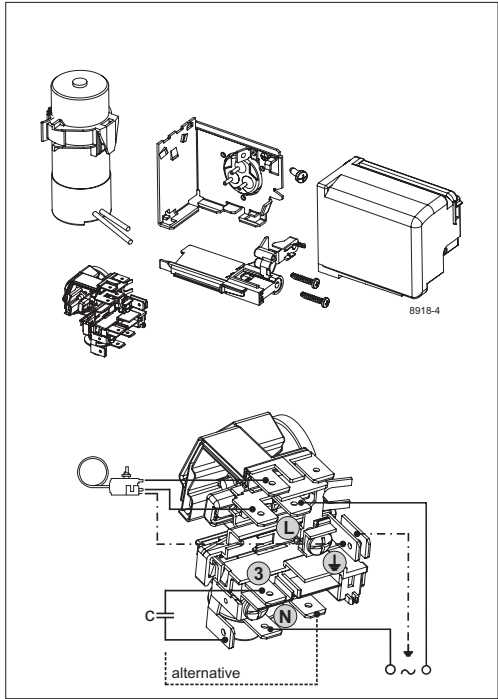
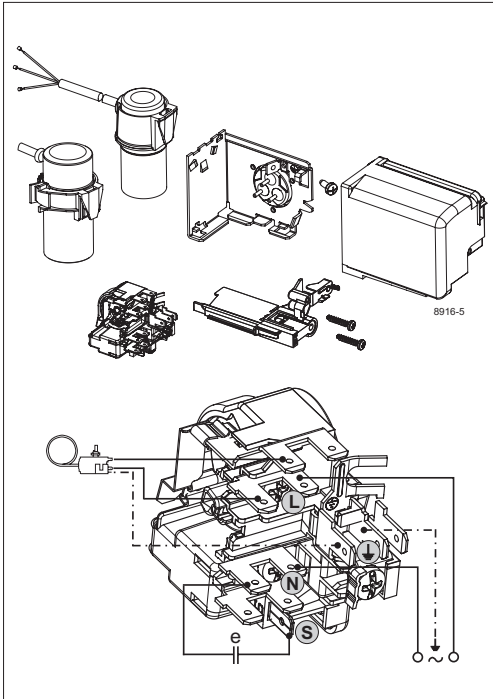
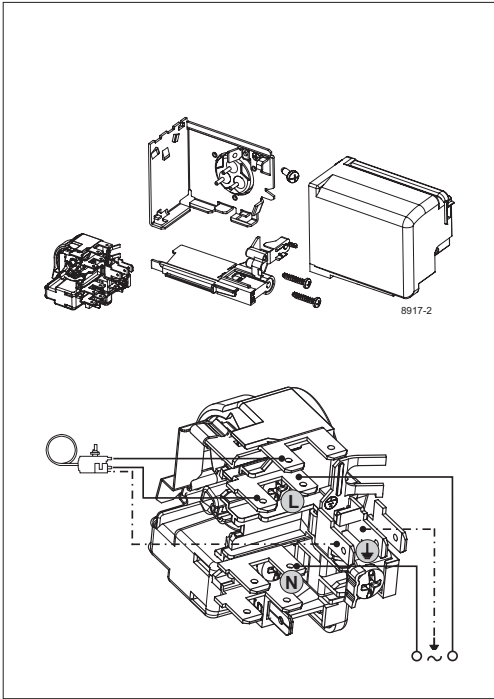

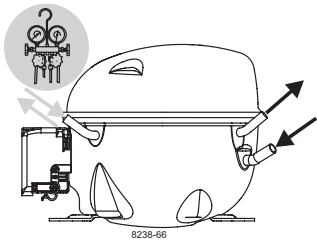

KL Compressors



Service/Repair – R290

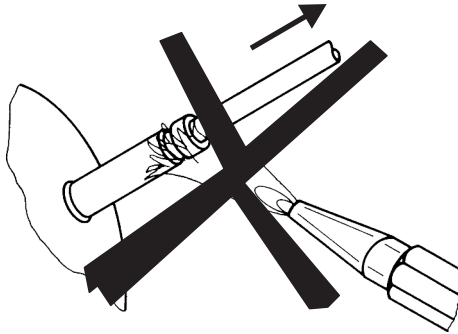

8545

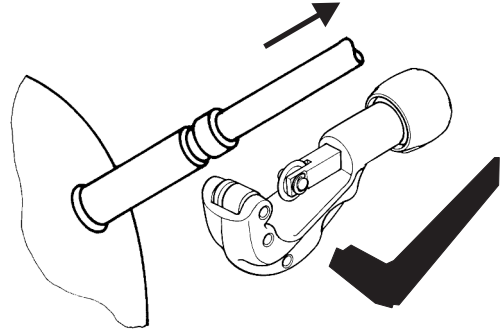

Secop accepts no responsibility for possible errors in catalogs, brochures, and other printed material. Secop reserves the right to alter its products without notice. This also applies to products already on order provided that such alterations can be made without subsequent changes being necessary to specifications already agreed. All trademarks in this material are the property of the respective companies. Secop and the Secop logotype are trademarks of Secop GmbH. All rights reserved. www.secop.com