

Single Pack TL4G 100-115V 50/60Hz CSIR

Single pack code number: **195B4107**

Position	Title	Code	Amount
1	Compressor TL4G	102G3460	1
2	Starting relay	117U6003	1
3	Starting capacitor (240 μ F 125V, 6.3mm)	117U5023	1
4	Cord relief	103N1010	1
5	Cover	103N2011	1
6	Bolt joint for one compressor M6 \varnothing 16mm	118-1917	1

Secop GmbH • Lise-Meitner-Straße 29 • 24941 Flensburg, Germany • Tel: +49 461 4941 0 • www.secop.com

Secop accepts no responsibility for possible errors in catalogs, brochures, and other printed material. Secop reserves the right to alter its products without notice. This also applies to products already on order provided that such alterations can be made without subsequent changes being necessary to specifications already agreed. All trademarks in this material are the property of the respective companies. Secop and the Secop logotype are trademarks of Secop GmbH. All rights reserved.

Model

Designation	TL4G	100-115V/50Hz 1~	100-115V/60Hz 1~	Sales code:	102G3460
-------------	-------------	------------------	------------------	-------------	-----------------

Compressor design

Oil type	Polyolester	Refrigerant(s)	R134a, R513A, 0
Oil viscosity	15cST	Displacement	3,86cm ³ / 0,24cu.in
Oil quantity	285cm ³ / 9,7fl.oz	Compressors on pallet	125
Refr. charge - tech. limit	400g / 14,1oz		
Free gas volume comp.	1600cm ³ / 54,1fl.oz		
Weight	7,5kg / 16,5lbs		
Motor protection	1# internal		
Winding resistance main	3,2Ω (at 25°C)		
Winding resistance aux	3,4Ω (at 25°C)		
Max. winding temp.	125°C / 257°F		
Max. discharge temp.	130°C / 266°F		



General - Configurations with TL4G

	Conf. 1	Conf. 2	Conf. 3	Conf. 4	Conf. 5
Motorconfiguration	CSIR	CSIR	RSIR	CSIR	CSIR
Power supply (nominal)	100-115V/50Hz	115V/60Hz	100-115V/50Hz	100-115V/50Hz	115V/60Hz
Number of phases	1	1	1	1	1
Voltage range	90-127V	90-135V	90-127V	90-127V	90-135V
Approvals	UL	UL	UL	UL	UL
Starting torque	HST	HST	LST	LST	LST
Note	- / -				

Applications with TL4G

	Conf. 1	Conf. 2	Conf. 3	Conf. 4	Conf. 5
Refrigerant	R134a	R134a	R134a	R513A	R513A
Application	LBP+MBP+HBP	LBP+MBP+HBP	LBP+MBP+HBP	LBP+MBP+HBP	LBP+MBP+HBP
System cooling	static	static	static	static	static
Hot gas defrost	OK	OK	OK	OK	OK
Long interval pull down	OK	OK	OK	OK	OK

Electrical data - Configurations with TL4G

	Conf. 1	Conf. 2	Conf. 3	Conf. 4	Conf. 5
Starting device type	relay	relay	PTC	relay	relay
Run capacitor	- / -	- / -	- / -	- / -	- / -
Start capacitor	240μF	240μF	- / -	240μF	240μF
LRA (locked rotor amps / 4s/ U(N))	14,2A				
RLA (rated load amps / 1s/ U(N))	2,5A	- / A	- / A	- / A	- / A
Cut in current (U(N))	22,6A				

Model

Designation

TL4G

100-115V/50Hz 1~ 100-115V/60Hz 1~

Sales code:

102G3460

Compressor dimensions

Housing	A Height	174mm / 6,85in
	B Height	168mm / 6,61in
	C Length shell	176mm / 6,93in
	D Length w. cover	222mm / 8,74in
	E Width	156mm / 6,14in

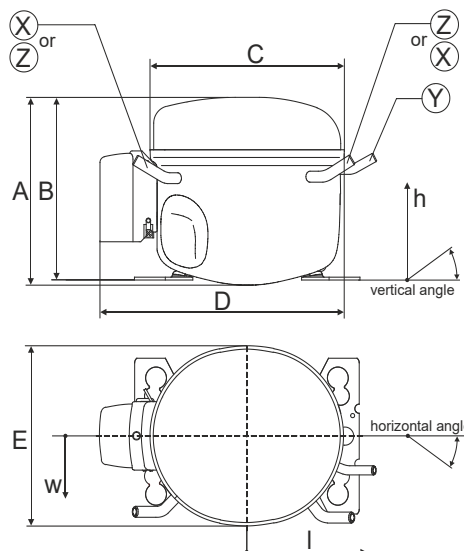

Connectors		Suction	Discharge	Process
		X	Y	Z
Diameter	[mm]	øi 6,41-6,59	øi 5,12-5,22	øi 6,41-6,59
	(i:inside, o:outside) [in]	øi 0,25-0,26	øi 0,2-0,21	øi 0,25-0,26
Material		copper	copper	copper
Horizontal angle	±2°	0°	0°	0°
Vertical angle	±2°	150°	28°	31,5°
Position l/h/w	[mm]	-102/105/66	117/108/30	95/105/71
	[in]	-4/4,1/2,6	4,6/4,3/1,2	3,7/4,1/2,8
Straight tube l.	[mm]	12	12	12
	[in]	0,5	0,5	0,5

Compressor fixation

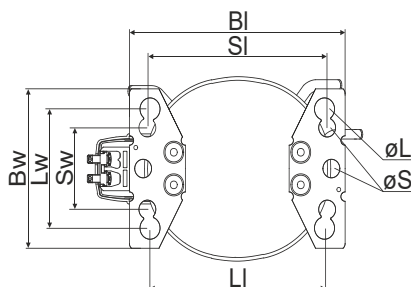

Baseplate	[mm]	[inch]
BI	204	8.03
BW	136	5.35
Large holes		
LI	165	6.5
LW	101.6	4
øL	ø 19	ø 0.75
Small holes		
SI	170	6.7
SW	70	2.76
øS	ø 16	ø 0.63

Bolt joint



Snap-on



Mounting accessories	one comp.	multi pack
Bolt joint M6 ø16mm	118-1917	118-1918
Bolt joint ø1/4" ø16mm	118-1946	
Bolt joint ø1/4" ø19mm	118-1949	
Snap-on ø7,3 ø16mm	118-1947	118-1919

Application notes

Provision for PE Grounding is located at the PE Stamp on the compressor

Model

Designation	TL4G	100-115V/50Hz	Conf. 1	Sales code:	102G3460
-------------	-------------	----------------------	---------	-------------	-----------------

Configuration

Motorconfiguration	CSIR
Power supply (nominal)	100-115V/50Hz 1~
Refrigerant	R134a
Application	LBP+MBP+HBP
Voltage range	90-127V
Starting torque	HST
Approvals	UL

Electrical accessories / wiring diagram



Ambient/ machine room temperatures minimum /maximum

Ambient temperature range:	10 - 43°C / 50 - 110°F
Machine room temperature range:	10 - 48°C / 50 - 119°F
Compressor cooling:	static

Operation pressure range

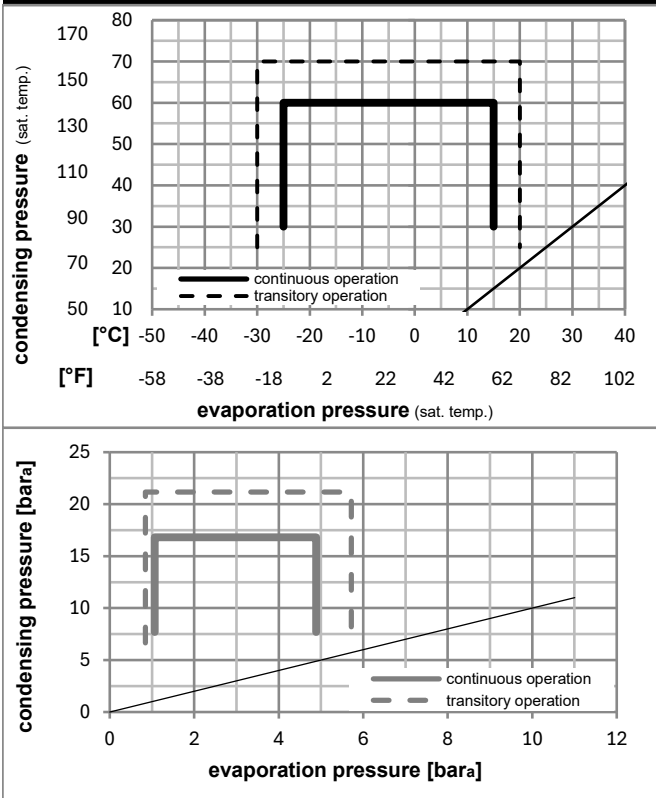

Components

a2	assy. relay	117U6003
c	start capacitor (240µF)	117U5023
b	plastic cover	103N2011
d	cord relief	103N1010

Model

Designation **TL4G** **100-115V/50Hz** Conf. 1 Sales code: **102G3460**

Optimization + standard conditions

R134a, 115V/50Hz, CSIR, static, UL

	Evaporating pressure (saturation temperature)				Cooling capacity			COP	EER	P1	Power consumption		ASHRAE	
	pe	pc	RGT	Tliq	[W]	[Btu/h]	[kcal/h]				I	m		
	[°C]	[°F]	[°C]	[°F]	[W]	[Btu/h]	[kcal/h]	[W/W]	[Btu/Wh]	[kcal/Wh]	[W]	[A]	[kg/h]	
	-23	54	32	32	74,6	255	64,2	0,78	2,66	0,67	95,7	1,75	1,45	ASHRAE LBP
	-10	130	90	90										
	-7	54	35	46	179,6	613	154,6	1,22	4,17	1,05	147,3	1,96	3,92	ASHRAE MBP
	20	130	95	115										
	7,2	54	35	46	337,4	1152	290,4	1,71	5,85	1,47	197,0	2,41	7,49	ASHRAE HBP
	45	130	95	115										
	-35	40	20	40	28,3	97	24,4	0,35	1,20	0,30	80,7	1,68	0,62	EN12900 LBP
	-31	104	68	104										
	-10	45	20	45	163,0	557	140,3	1,24	4,25	1,07	130,9	1,89	3,82	EN12900 MBP
	14	113	68	113										
	5	50	20	50	288,8	986	248,6	1,57	5,38	1,35	183,5	2,29	7,28	EN12900 HBP
	41	122	68	122										

Performance tables

R134a, 115V/50Hz, CSIR, static, UL

	pe		Cooling capacity			COP	EER		P1	I	m
	[°C]	[°F]	[W]	[Btu/h]	[kcal/h]		[Btu/Wh]	[kcal/Wh]			
[°C / °F]	-25	-13	68,1	233	58,6	0,73	2,48	0,62	93,9	1,75	1,48
cond. pressure	-23	-10	76,8	262	66,1	0,79	2,69	0,68	97,4	1,76	1,67
pc= 45/113	-9	15	173,9	594	149,6	1,31	4,48	1,13	132,5	1,90	3,81
return gas temp.	-4	25	226,3	773	194,8	1,52	5,19	1,31	148,8	2,00	4,98
RGT= 32/90	0	32	268,2	916	230,8	1,67	5,70	1,44	160,7	2,09	5,93
liquid temp	4,4	40	321,7	1099	276,8	1,84	6,30	1,59	174,5	2,22	7,16
Tliq= 45/113	15	59	474,1	1619	408,0	2,29	7,82	1,97	207,1	2,68	10,74
[°C / °F]	-25	-13	53,7	183	46,2	0,59	2,01	0,51	91,1	1,73	1,28
cond. pressure	-23	-10	60,3	206	51,9	0,63	2,16	0,54	95,4	1,75	1,44
pc= 55/131	-9	15	140,2	479	120,6	1,02	3,47	0,87	137,9	1,91	3,39
return gas temp	-4	25	185,8	635	159,9	1,18	4,03	1,02	157,3	2,03	4,52
RGT= 32/90	0	32	222,9	761	191,9	1,30	4,45	1,12	171,2	2,14	5,45
liquid temp	4,4	40	271,0	925	233,2	1,45	4,94	1,24	187,5	2,30	6,67
Tliq= 55/131	15	59	410,7	1403	353,5	1,82	6,21	1,56	225,9	2,84	10,32

Model

Designation	TL4G	115V/60Hz	Conf. 2	Sales code:	102G3460
-------------	-------------	------------------	----------------	-------------	-----------------

Configuration

Motorconfiguration	CSIR
Power supply (nominal)	115V/60Hz 1~
Refrigerant	R134a
Application	LBP+MBP+HBP
Voltage range	90-135V
Starting torque	HST
Approvals	UL

Electrical accessories / wiring diagram



Ambient/ machine room temperatures minimum /maximum

Ambient temperature range:	10 - 43°C / 50 - 110°F
Machine room temperature range:	10 - 48°C / 50 - 119°F
Compressor cooling:	static

Operation pressure range

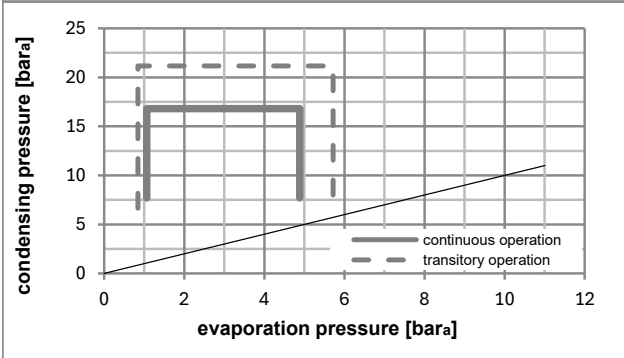
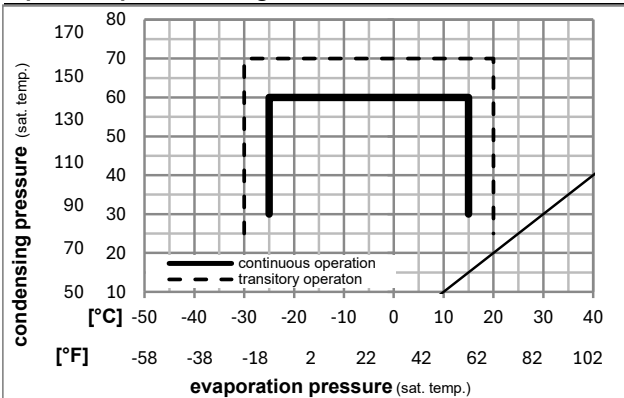

Components

a2	assy. relay	117U6003
c	start capacitor (240µF)	117U5023
b	plastic cover	103N2011
d	cord relief	103N1010

Model

Designation	TL4G	115V/60Hz	Conf. 2	Sales code:	102G3460
-------------	-------------	------------------	----------------	-------------	-----------------

Optimization + standard conditions

R134a, 115V/60Hz, CSIR, static, UL

	Evaporating pressure (saturation temperature)				Cooling capacity			COP	EER			Power consumption			ASHRAE
	pe	pc	RGT	Tliq	[W]	[Btu/h]	[kcal/h]		[W/W]	[Btu/Wh]	[kcal/Wh]	P1	I	m	
	[°C]	[°C]	[°C]	[°C]							[W]	[A]	[kg/h]		
	-23	54	32	32	89,5	306	77,0	0,94	3,19	0,81	95,7	1,75	1,74	ASHRAE LBP	
	[°F]														
	-10	130	90	90											
	[°C]														
	-7	54	35	46	215,6	736	185,5	1,46	5,00	1,26	147,3	1,96	4,70	ASHRAE MBP	
	[°F]														
	20	130	95	115											
	[°C]														
	7,2	54	35	46	404,9	1383	348,5	2,06	7,02	1,77	197,0	2,41	8,98	ASHRAE HBP	
	[°F]														
	45	130	95	115											
	[°C]														
	-35	40	20	40	34,0	116	29,2	0,42	1,44	0,36	80,7	1,68	0,75	EN12900 LBP	
	[°F]														
	-31	104	68	104											
	[°C]														
	-10	45	20	45	195,6	668	168,3	1,49	5,10	1,29	130,9	1,89	4,58	EN12900 MBP	
	[°F]														
	14	113	68	113											
	[°C]														
	5	50	20	50	346,6	1184	298,3	1,89	6,45	1,63	183,5	2,29	8,73	EN12900 HBP	
	[°F]														
	41	122	68	122											
	[°C]														

Performance tables

R134a, 115V/60Hz, CSIR, static, UL

	pe		Cooling capacity			COP	EER			P1	I	m
	[°C]	[°F]	[W]	[Btu/h]	[kcal/h]		[W/W]	[Btu/Wh]	[kcal/Wh]			
[°C / °F]	-25	-13	81,7	279	70,3	0,87	2,97	0,75	93,9	1,75	1,77	
cond. pressure	-23	-10	92,2	315	79,3	0,95	3,23	0,81	97,4	1,76	2,00	
pc= 45/113	-9	15	208,7	713	179,6	1,57	5,38	1,36	132,5	1,90	4,57	
return gas temp.	-4	25	271,6	928	233,7	1,82	6,23	1,57	148,8	2,00	5,98	
RGT= 32/90	0	32	321,9	1099	277,0	2,00	6,84	1,72	160,7	2,09	7,12	
liquid temp	4,4	40	386,0	1318	332,2	2,21	7,55	1,90	174,5	2,22	8,59	
Tliq= 45/113	15	59	569,0	1943	489,7	2,75	9,38	2,36	207,1	2,68	12,89	
[°C / °F]	-25	-13	64,4	220	55,4	0,71	2,41	0,61	91,1	1,73	1,54	
cond. pressure	-23	-10	72,4	247	62,3	0,76	2,59	0,65	95,4	1,75	1,73	
pc= 55/131	-9	15	168,2	574	144,7	1,22	4,16	1,05	137,9	1,91	4,07	
return gas temp	-4	25	222,9	761	191,9	1,42	4,84	1,22	157,3	2,03	5,43	
RGT= 32/90	0	32	267,5	914	230,2	1,56	5,34	1,34	171,2	2,14	6,54	
liquid temp	4,4	40	325,2	1110	279,8	1,73	5,92	1,49	187,5	2,30	8,01	
Tliq= 55/131	15	59	492,9	1683	424,2	2,18	7,45	1,88	225,9	2,84	12,38	

Model

Designation **TL4G** **100-115V/50Hz** Conf. 3 Sales code: **102G3460**

Configuration

Motorconfiguration RSIR
 Power supply (nominal) 100-115V/50Hz 1~
 Refrigerant R134a
 Application LBP+MBP+HBP
 Voltage range 90-127V
 Starting torque LST
 Approvals UL

Electrical accessories / wiring diagram

RSIR

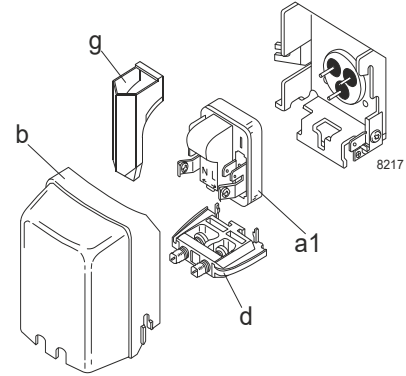

Ambient/ machine room temperatures minimum /maximum

Ambient temperature range: 10 - 43°C / 50 - 110°F
 Machine room temperature range: 10 - 48°C / 50 - 119°F
 Compressor cooling: static

Operation pressure range

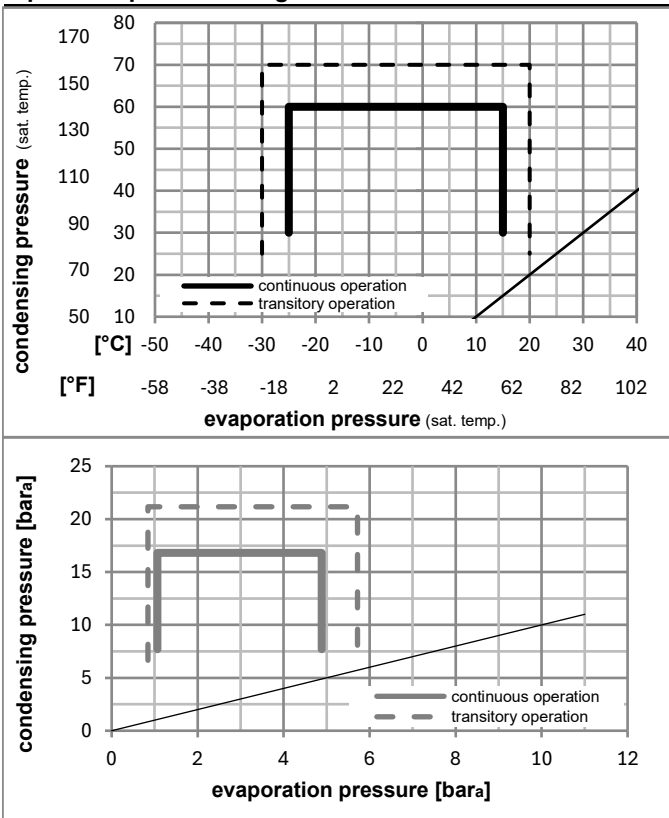

Components

a1	PTC starter (115V, 50hm, 6.3mm)	103N0026
b	plastic cover	103N2011
d	cord relief	103N1010
g	protection screen for PTC	103N0476

Alternative components

a1	PTC starter (115V, 50hm, 4.8mm)	103N0023
b	plastic cover	103N2011
d	cord relief	103N1010
g	protection screen for PTC	103N0476

Model

Designation **TL4G** **100-115V/50Hz** Conf. 3 Sales code: **102G3460**

Optimization + standard conditions

R134a, 115V/50Hz, RSIR, static, UL

	Evaporating pressure (saturation temperature)				Condensing pressure (saturation temperature)			Return gas temp.			Liquid temp.			Cooling capacity			COP	EER	Power consumption			
	pe	pc	RGT	Tliq	[W]	[Btu/h]	[kcal/h]	[W/W]	[Btu/Wh]	[kcal/Wh]	P1	I	Ref. mass flow									
[°C]											[W]	[A]	[kg/h]									
[°F]	-23	54	32	32	74,6	255	64,2	0,78	2,66	0,67	95,7	1,75	1,45								ASHRAE LBP	
	-10	130	90	90																		
[°C]	-7	54	35	46	179,6	613	154,6	1,22	4,17	1,05	147,3	1,96	3,92								ASHRAE MBP	
[°F]	20	130	95	115																		
[°C]	7,2	54	35	46	337,4	1152	290,4	1,71	5,85	1,47	197,0	2,41	7,49								ASHRAE HBP	
[°F]	45	130	95	115																		
[°C]	-35	40	20	40	28,3	97	24,4	0,35	1,20	0,30	80,7	1,68	0,62								EN12900 LBP	
[°F]	-31	104	68	104																		
[°C]	-10	45	20	45	163,0	557	140,3	1,24	4,25	1,07	130,9	1,89	3,82								EN12900 MBP	
[°F]	14	113	68	113																		
[°C]	5	50	20	50	288,8	986	248,6	1,57	5,38	1,35	183,5	2,29	7,28								EN12900 HBP	
[°F]	41	122	68	122																		

Performance tables

R134a, 115V/50Hz, RSIR, static, UL

	pe		Cooling capacity			COP	EER	P1	I	m	
	[°C]	[°F]	[W]	[Btu/h]	[kcal/h]	[W/W]	[Btu/Wh]	[kcal/Wh]	[W]	[A]	[kg/h]
[°C / °F]	-25	-13	68,1	233	58,6	0,73	2,48	0,62	93,9	1,75	1,48
cond. pressure	-23	-10	76,8	262	66,1	0,79	2,69	0,68	97,4	1,76	1,67
pc= 45/113	-9	15	173,9	594	149,6	1,31	4,48	1,13	132,5	1,90	3,81
return gas temp.	-4	25	226,3	773	194,8	1,52	5,19	1,31	148,8	2,00	4,98
RGT= 32/90	0	32	268,2	916	230,8	1,67	5,70	1,44	160,7	2,09	5,93
liquid temp	4,4	40	321,7	1099	276,8	1,84	6,30	1,59	174,5	2,22	7,16
Tliq= 45/113	15	59	474,1	1619	408,0	2,29	7,82	1,97	207,1	2,68	10,74
[°C / °F]	-25	-13	53,7	183	46,2	0,59	2,01	0,51	91,1	1,73	1,28
cond. pressure	-23	-10	60,3	206	51,9	0,63	2,16	0,54	95,4	1,75	1,44
pc= 55/131	-9	15	140,2	479	120,6	1,02	3,47	0,87	137,9	1,91	3,39
return gas temp	-4	25	185,8	635	159,9	1,18	4,03	1,02	157,3	2,03	4,52
RGT= 32/90	0	32	222,9	761	191,9	1,30	4,45	1,12	171,2	2,14	5,45
liquid temp	4,4	40	271,0	925	233,2	1,45	4,94	1,24	187,5	2,30	6,67
Tliq= 55/131	15	59	410,7	1403	353,5	1,82	6,21	1,56	225,9	2,84	10,32

Model

Designation	TL4G	100-115V/50Hz	Conf. 4	Sales code:	102G3460
-------------	-------------	----------------------	----------------	-------------	-----------------

Configuration

Motorconfiguration	CSIR
Power supply (nominal)	100-115V/50Hz 1~
Refrigerant	R513A
Application	LBP+MBP+HBP
Voltage range	90-127V
Starting torque	LST
Approvals	UL

Electrical accessories / wiring diagram

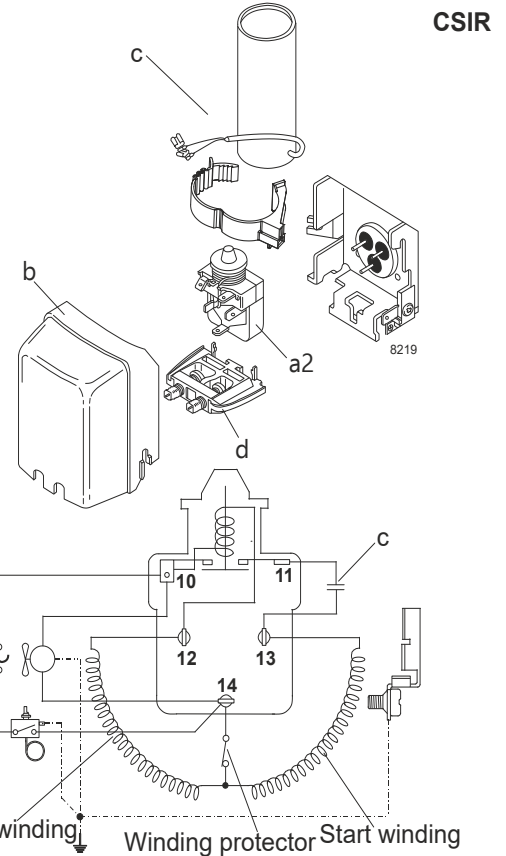

Ambient/ machine room temperatures minimum /maximum

Ambient temperature range:	10 - 43°C / 50 - 110°F
Machine room temperature range:	10 - 48°C / 50 - 119°F
Compressor cooling:	static

Operation pressure range

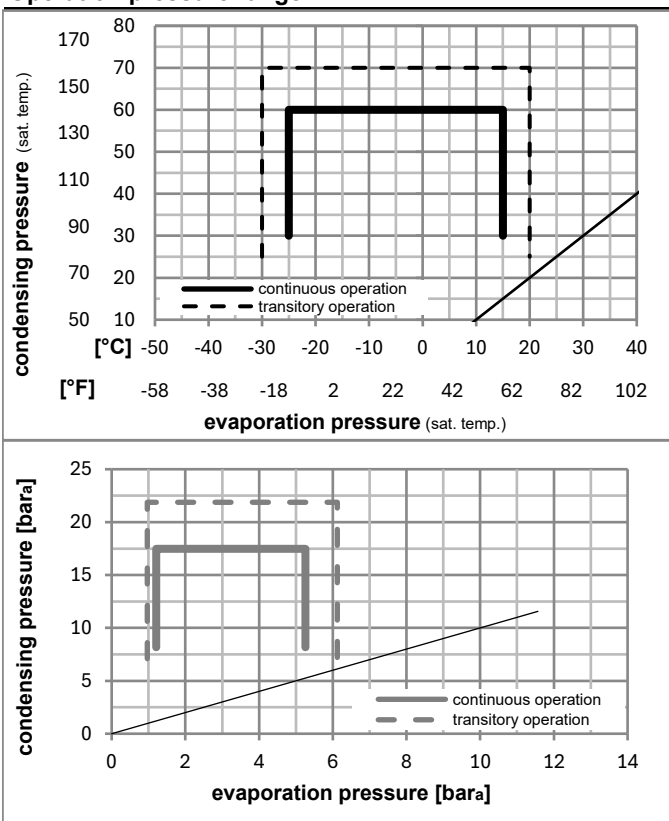

Components

a2	assy. relay	117U6003
c	start capacitor (240µF)	117U5023
b	plastic cover	103N2011
d	cord relief	103N1010

Model

Designation	TL4G	100-115V/50Hz	Conf. 4	Sales code:	102G3460
-------------	-------------	----------------------	----------------	-------------	-----------------

Optimization + standard conditions

R513A, 115V/50Hz, CSIR, static, UL

		Evaporating pressure (saturation temperature)				Condensing pressure (saturation temperature)			Return gas temp.			Liquid temp.			Cooling capacity			COP	EER	Power consumption			
		pe	pc	RGT	Tliq	[W]	[Btu/h]	[kcal/h]	[W/W]	[Btu/Wh]	[kcal/Wh]	P1	I	m	[W]	[A]	[kg/h]						
[°C]	[°F]	[°C]	[°F]	[°C]	[°F]																		
-23	-10	54	130	32	90	82,4	282	71,0	0,80	2,73	0,69	103,1	1,67	1,77							ASHRAE LBP		
-7	20	54	130	35	95	188,2	643	162,0	1,21	4,12	1,04	155,9	2,01	4,61							ASHRAE MBP		
7,2	45	54	130	35	95	346,3	1183	298,0	1,68	5,74	1,45	206,1	2,39	8,60							ASHRAE HBP		
-35	-31	40	104	20	68	31,6	108	27,2	0,36	1,22	0,31	88,3	1,60	0,78							EN12900 LBP		
-10	14	45	113	20	68	170,1	581	146,4	1,23	4,19	1,06	138,7	1,89	4,51							EN12900 MBP		
5	41	50	122	20	68	292,6	999	251,8	1,52	5,20	1,31	192,3	2,28	8,39							EN12900 HBP		

Performance tables

R513A, 115V/50Hz, CSIR, static, UL

	pe		Cooling capacity			COP	EER	P1	I	m	
	[°C]	[°F]	[W]	[Btu/h]	[kcal/h]	[W/W]	[Btu/Wh]	[kcal/Wh]	[W]	[A]	[kg/h]
[°C / °F]	-25	-13	74,0	253	63,7	0,73	2,50	0,63	101,1	1,66	1,80
cond. pressure	-23	-10	83,1	284	71,5	0,79	2,71	0,68	104,6	1,68	2,03
pc= 45/113	-9	15	182,8	624	157,3	1,30	4,45	1,12	140,4	1,90	4,50
return gas temp.	-4	25	235,7	805	202,9	1,50	5,13	1,29	157,0	2,02	5,83
RGT= 32/90	0	32	277,8	949	239,1	1,64	5,61	1,41	169,0	2,10	6,89
liquid temp	4,4	40	331,1	1131	285,0	1,81	6,18	1,56	182,9	2,21	8,25
Tliq= 45/113	15	59	482,0	1646	414,9	2,24	7,65	1,93	215,2	2,47	12,20
[°C / °F]	-25	-13	57,7	197	49,7	0,59	2,00	0,50	98,4	1,65	1,58
cond. pressure	-23	-10	64,6	220	55,6	0,63	2,14	0,54	102,8	1,67	1,77
pc= 55/131	-9	15	145,0	495	124,8	0,99	3,38	0,85	146,4	1,94	4,01
return gas temp	-4	25	190,3	650	163,8	1,15	3,91	0,99	166,1	2,08	5,29
RGT= 32/90	0	32	227,0	775	195,3	1,26	4,30	1,08	180,3	2,19	6,34
liquid temp	4,4	40	274,2	936	235,9	1,39	4,76	1,20	196,6	2,32	7,70
Tliq= 55/131	15	59	410,6	1402	353,3	1,75	5,97	1,51	234,8	2,64	11,73

Model

Designation	TL4G	115V/60Hz	Conf. 5	Sales code:	102G3460
-------------	-------------	------------------	----------------	-------------	-----------------

Configuration

Motorconfiguration	CSIR
Power supply (nominal)	115V/60Hz 1~
Refrigerant	R513A
Application	LBP+MBP+HBP
Voltage range	90-135V
Starting torque	LST
Approvals	UL

Electrical accessories / wiring diagram

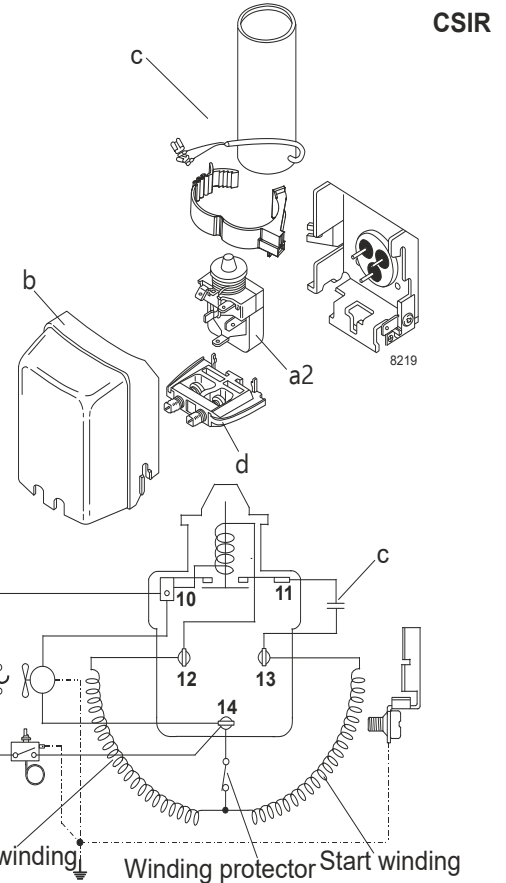

Ambient/ machine room temperatures minimum /maximum

Ambient temperature range:	10 - 43°C / 50 - 110°F
Machine room temperature range:	10 - 48°C / 50 - 119°F
Compressor cooling:	static

Operation pressure range

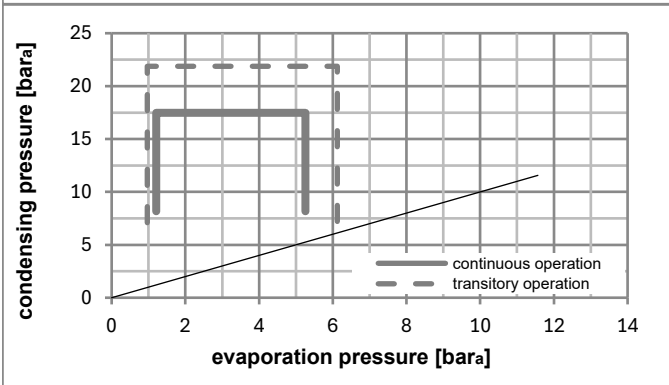
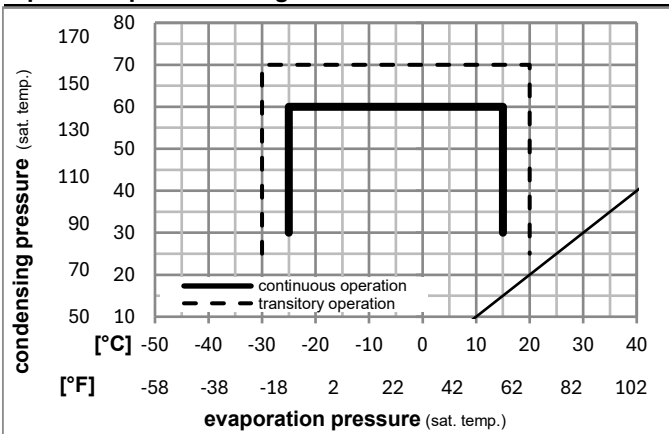

Components

a2	assy. relay	117U6003
c	start capacitor (240µF)	117U5023
b	plastic cover	103N2011
d	cord relief	103N1010

Model

Designation	TL4G	115V/60Hz	Conf. 5	Sales code:	102G3460
-------------	-------------	------------------	----------------	-------------	-----------------

Optimization + standard conditions

R513A, 115V/60Hz, CSIR, static, UL

		Evaporating pressure (saturation temperature)				Cooling capacity			COP			EER			Power consumption			
		Condensing pressure (saturation temperature)		Return gas temp.		Liquid temp.								Current consumption			Ref. mass flow	
		pe	pc	RGT	Tliq	[W]	[Btu/h]	[kcal/h]	[W/W]	[Btu/Wh]	[kcal/Wh]	P1	I	m				
[°C]	[°F]	[°C]	[°F]	[°C]	[°C]							[W]	[A]	[kg/h]				
-23	-10	54	130	32	32	99,1	338	85,3	0,96	3,28	0,83	103,1	1,68	2,13		ASHRAE LBP		
-7	20	54	130	35	46	226,2	773	194,7	1,45	4,96	1,25	155,9	2,01	5,54		ASHRAE MBP		
7,2	45	54	130	35	46	416,5	1422	358,4	2,03	6,92	1,74	205,5	2,38	10,35		ASHRAE HBP		
-35	-31	40	104	20	40	37,9	130	32,6	0,43	1,48	0,37	87,4	1,62	0,94		EN12900 LBP		
-10	14	45	113	20	45	204,5	698	176,0	1,47	5,03	1,27	138,9	1,89	5,42		EN12900 MBP		
5	41	50	122	20	50	351,8	1201	302,7	1,83	6,25	1,58	192,1	2,27	10,09		EN12900 HBP		

Performance tables

R513A, 115V/60Hz, CSIR, static, UL

	pe		Cooling capacity			COP			EER			P1	I	m
	[°C]	[°F]	[W]	[Btu/h]	[kcal/h]	[W/W]	[Btu/Wh]	[kcal/Wh]	[W]	[A]	[kg/h]			
[°C / °F]	-25	-13	88,9	304	76,5	0,88	3,01	0,76	100,8	1,67	2,17			
cond. pressure	-23	-10	99,8	341	85,9	0,96	3,27	0,82	104,4	1,69	2,44			
pc= 45/113	-9	15	219,7	750	189,0	1,56	5,34	1,35	140,5	1,90	5,40			
return gas temp.	-4	25	283,4	968	243,9	1,80	6,16	1,55	157,1	2,01	7,00			
RGT= 32/90	0	32	333,9	1140	287,4	1,97	6,74	1,70	169,1	2,10	8,28			
liquid temp	4,4	40	398,1	1359	342,6	2,18	7,44	1,87	182,8	2,20	9,92			
Tliq= 45/113	15	59	579,7	1980	498,9	2,70	9,23	2,33	214,5	2,46	14,67			
[°C / °F]	-25	-13	69,4	237	59,7	0,71	2,41	0,61	98,4	1,66	1,90			
cond. pressure	-23	-10	77,6	265	66,8	0,75	2,58	0,65	102,9	1,68	2,13			
pc= 55/131	-9	15	174,3	595	150,0	1,19	4,07	1,02	146,4	1,94	4,82			
return gas temp	-4	25	228,8	781	196,9	1,38	4,71	1,19	166,0	2,08	6,36			
RGT= 32/90	0	32	272,9	932	234,9	1,52	5,18	1,30	180,0	2,18	7,62			
liquid temp	4,4	40	329,7	1126	283,7	1,68	5,74	1,45	196,2	2,31	9,26			
Tliq= 55/131	15	59	493,9	1687	425,1	2,11	7,22	1,82	233,6	2,63	14,11			



TL Compressors



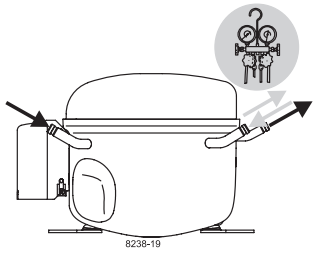

Service/Repair – R600a, R290

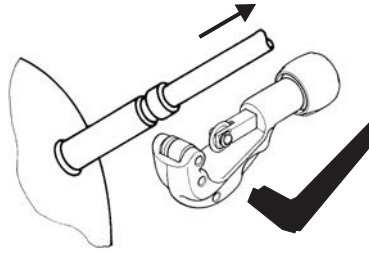

8545

Brazing on Suction Connectors (Direct Intake)

representative image

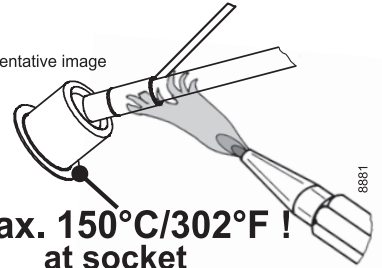

**! max. 150°C/302°F !
at socket**
brazing solder: phosphor (LP7) or silver

Refer to Product Bulletin:
**Brazing on Suction Connectors
(Compressors with Direct Suction Intake)**

Secop accepts no responsibility for possible errors in catalogs, brochures, and other printed material. Secop reserves the right to alter its products without notice. This also applies to products already on order provided that such alterations can be made without subsequential changes being necessary to specifications already agreed. All trademarks in this material are the property of the respective companies. Secop and the Secop logotype are trademarks of Secop GmbH. All rights reserved. www.secop.com