

## Single Pack SC12G 115V 60Hz CSIR

Single pack code number: **195B4120**

Position	Title	Code	Amount
1	Compressor SC12G	104G7250	1
2	Starting relay	117U6020	1
3	Starting capacitor (240 $\mu$ F 125V, 6.3mm)	117U5023	1
4	Cord relief	103N1004	1
5	Cover	103N2008	1
6	Bolt joint for one compressor   M6   $\varnothing$ 16mm	118-1917	1

**Secop GmbH** • Lise-Meitner-Straße 29 • 24941 Flensburg, Germany • Tel: +49 461 4941 0 • [www.secop.com](http://www.secop.com)

Secop accepts no responsibility for possible errors in catalogs, brochures, and other printed material. Secop reserves the right to alter its products without notice. This also applies to products already on order provided that such alterations can be made without subsequent changes being necessary to specifications already agreed. All trademarks in this material are the property of the respective companies. Secop and the Secop logotype are trademarks of Secop GmbH. All rights reserved.

## Model

Designation	<b>SC12G</b>	115V/60Hz 1~	Sales code:	<b>104G7250</b>
-------------	--------------	--------------	-------------	-----------------

## Compressor design

Oil type	Polyolester	Refrigerant(s)	<b>R134a, R513A</b>
Oil viscosity	22cST	Displacement	12,87cm <sup>3</sup> / 0,79cu.in
Oil quantity	500cm <sup>3</sup> / 16,9fl.oz	Compressors on pallet	80
Refr. charge - tech. limit	1300g / 45,9oz		
Free gas volume comp.	1460cm <sup>3</sup> / 49,4fl.oz		
Weight	13,1kg / 28,9lbs		
Motor protection	1# internal		
Winding resistance main	0,98Ω (at 25°C)		
Winding resistance aux	4,18Ω (at 25°C)		
Max. winding temp.	125°C / 257°F		
Max. discharge temp.	135°C / 275°F		



## General - Configurations with SC12G

	<b>Conf. 1</b>	<b>Conf. 2</b>
Motorconfiguration	CSIR	CSIR
Power supply (nominal)	115V/60Hz	115V/60Hz
Number of phases	1	1
Voltage range	103-127V	103-127V
Approvals	UL	UL
Starting torque	HST	HST
Note	- / -	

## Applications with SC12G

	<b>Conf. 1</b>	<b>Conf. 2</b>
Refrigerant	R134a	R513A
Application	LBP+MBP+HBP	LBP+MBP+HBP
System cooling	fan 1,5m/s	fan 1,5m/s
Hot gas defrost	OK	OK
Long interval pull down	OK	OK

## Electrical data - Configurations with SC12G

	<b>Conf. 1</b>	<b>Conf. 2</b>
Starting device type	relay	relay
Run capacitor	- / -	- / -
Start capacitor	240μF	240μF
LRA (locked rotor amps / 4s)	23,4A	23,4A
RLA (rated load amps / 1s)	4,3A	4,3A
Cut in current	23,4A	23,4A

## Model

Designation

**SC12G**

115V/60Hz 1~

Sales code:

**104G7250**

## Compressor dimensions

Housing	A Height	209mm / 8,23in
	B Height	203mm / 7,99in
	C Length shell	218mm / 8,58in
	D Length w. cover	255mm / 10,04in
	E Width	151mm / 5,94in

Connectors	Suction X	Discharge Y	Process Z
Diameter [mm]	øi 8,11-8,29	øi 6,41-6,59	øi 6,41-6,59
(i:inside, o:outside) [in]	øi 0,32-0,33	øi 0,25-0,26	øi 0,25-0,26
Material	copper	copper	copper
Horizontal angle ±2°	37°	37°	143°
Vertical angle ±2°	30°	0°	150°
Position l/h/w [mm]	107/183/55	115/100/63	-107/183/55
[in]	4,2/7,2/2,2	4,5/3,9/2,5	-4,2/7,2/2,2
Straight tube l. [mm]	12	12	12
[in]	0,5	0,5	0,5

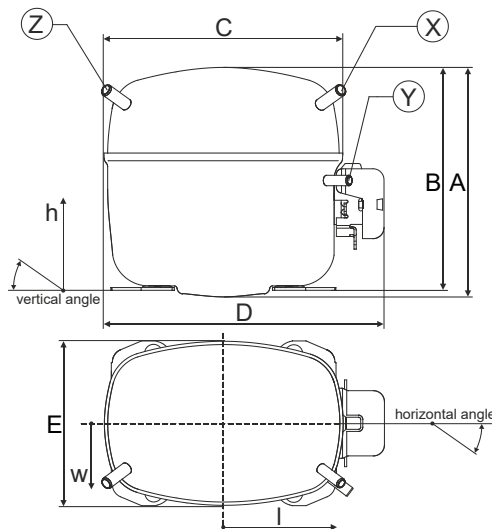

## Compressor fixation



## Bolt joint



## Snap-on



## Mounting accessories

Mounting accessories	one comp.	multi pack
Bolt joint   M6   ø16mm	118-1917	118-1918
Bolt joint   ø1/4"   ø16mm	118-1946	
Bolt joint   ø1/4"   ø19mm	118-1949	
Snap-on   ø7,3   ø16mm	118-1947	118-1919

## Application notes

Provision for PE Grounding is located at the PE Stamp on the compressor

## Model

Designation	<b>SC12G</b>	<b>115V/60Hz</b>	<b>Conf. 1</b>	Sales code:	<b>104G7250</b>
-------------	--------------	------------------	----------------	-------------	-----------------

## Configuration

Motorconfiguration	CSIR
Power supply (nominal)	115V/60Hz 1~
Refrigerant	R134a
Application	LBP+MBP+HBP
Voltage range	103-127V
Starting torque	HST
Approvals	UL

## Electrical accessories / wiring diagram

CSIR

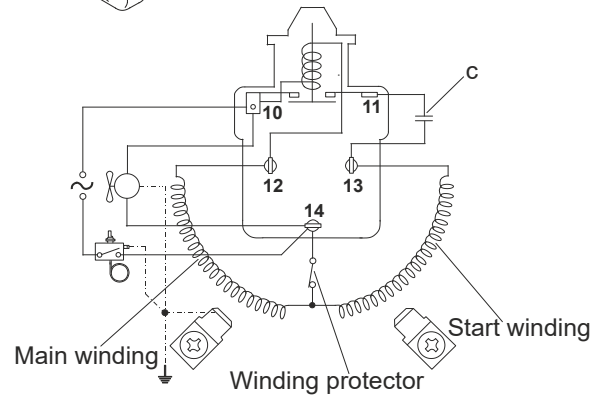
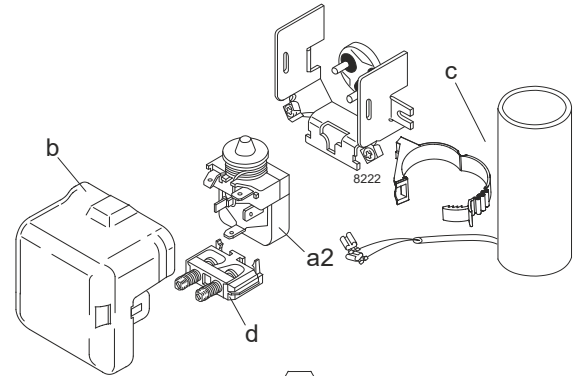

## Ambient/ machine room temperatures minimum /maximum

Ambient temperature range:	10 - 43°C / 50 - 110°F
Machine room temperature range:	10 - 48°C / 50 - 119°F
Compressor cooling:	fan 1,5m/s

## Operation Limits

## Operation pressure range

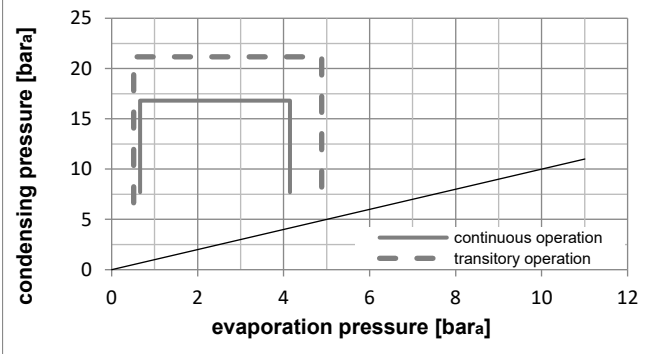
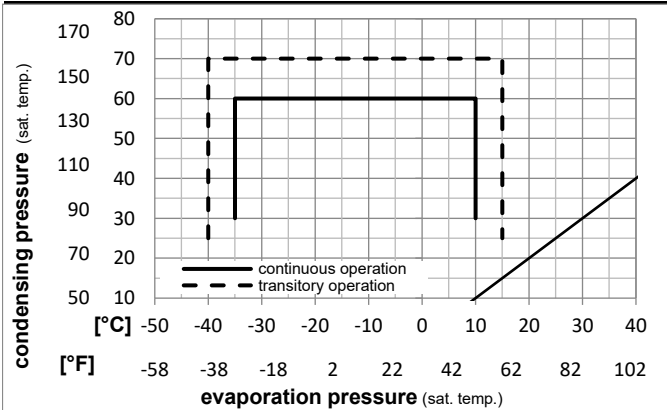

## Components

a2	relay	117U6020
c	start capacitor (240µF)	117U5023
d	cord relief	103N1004
b	plastic cover	103N2008

### Model

Designation	<b>SC12G</b>	<b>115V/60Hz</b>	<b>Conf. 1</b>	Sales code:	<b>104G7250</b>
-------------	--------------	------------------	----------------	-------------	-----------------

### Optimization + standard conditions

R134a, 115V/60Hz, CSIR, fan 1,5m/s, UL

	Evaporating pressure (saturation temperature)				Condensing pressure (saturation temperature)			Return gas temp.	Liquid temp.	Cooling capacity	COP	EER	Power consumption			ASHRAE LBP
	pe	pc	RGT	Tliq	[W]	[Btu/h]	[kcal/h]						P1	I	Ref. mass flow	
	[°C]	[°F]	[°C]	[°F]	[W]	[Btu/h]	[kcal/h]	[W/W]	[Btu/Wh]	[kcal/Wh]	[W]	[A]	[kg/h]			
	-23	54	32	32	294,8	1007	253,7	0,99	3,38	0,85	297,9	5,06	5,72	ASHRAE LBP		
	-10	130	90	90												
	-7	54	35	46	746,4	2549	642,3	1,56	5,33	1,34	478,3	6,05	16,28	ASHRAE MBP		
	20	130	95	115												
	7,2	54	35	46	1403,9	4795	1208,2	2,24	7,64	1,93	627,5	7,18	31,15	ASHRAE HBP		
	45	130	95	115												
	-35	40	20	40	131,1	448	112,8	0,64	2,20	0,55	203,8	4,92	2,88	EN12900 LBP		
	-31	104	68	104												
	-10	45	20	45	669,4	2286	576,1	1,59	5,44	1,37	420,3	5,71	15,67	EN12900 MBP		
	14	113	68	113												
	5	50	20	50	1204,3	4113	1036,4	2,09	7,13	1,80	576,7	6,85	30,35	EN12900 HBP		
	41	122	68	122												

### Performance tables

R134a, 115V/60Hz, CSIR, fan 1,5m/s, UL

	pe		Cooling capacity			COP	EER	P1	I	m	
	[°C]	[°F]	[W]	[Btu/h]	[kcal/h]	[W/W]	[Btu/Wh]	[kcal/Wh]	[W]	[A]	[kg/h]
[°C / °F]	-35	-31	118,0	403	101,6	0,61	2,08	0,52	193,5	4,81	2,55
cond. pressure	-23	-10	326,0	1113	280,6	1,06	3,64	0,92	306,3	5,12	7,07
pc= 45/113	-15	5	536,1	1831	461,4	1,42	4,84	1,22	378,3	5,46	11,69
return gas temp.	-9	15	713,7	2438	614,3	1,68	5,74	1,45	425,0	5,75	15,63
RGT= 32/90	0	32	1099,8	3756	946,5	2,17	7,42	1,87	505,9	6,34	24,32
liquid temp	4,4	40	1323,7	4521	1139,2	2,42	8,28	2,09	546,2	6,66	29,45
Tliq= 45/113	10	50	1646,5	5623	1417,0	2,74	9,37	2,36	600,1	7,11	36,95
[°C / °F]	-35	-31	42,6	146	36,7	0,28	0,97	0,24	149,8	4,61	1,01
cond. pressure	-23	-10	233,9	799	201,3	0,79	2,69	0,68	296,8	5,06	5,60
pc= 55/131	-15	5	421,7	1440	362,9	1,08	3,69	0,93	390,6	5,51	10,15
return gas temp	-9	15	579,7	1980	498,9	1,29	4,40	1,11	450,4	5,86	14,02
RGT= 32/90	0	32	923,6	3154	794,9	1,68	5,72	1,44	551,3	6,57	22,59
liquid temp	4,4	40	1123,9	3838	967,2	1,87	6,40	1,61	600,0	6,95	27,67
Tliq= 55/131	10	50	1413,6	4828	1216,6	2,13	7,28	1,83	663,4	7,47	35,14

## Model

Designation	<b>SC12G</b>	<b>115V/60Hz</b>	<b>Conf. 2</b>	Sales code:	<b>104G7250</b>
-------------	--------------	------------------	----------------	-------------	-----------------

## Configuration

Motorconfiguration	CSIR
Power supply (nominal)	115V/60Hz 1~
Refrigerant	R513A
Application	LBP+MBP+HBP
Voltage range	103-127V
Starting torque	HST
Approvals	UL

## Electrical accessories / wiring diagram

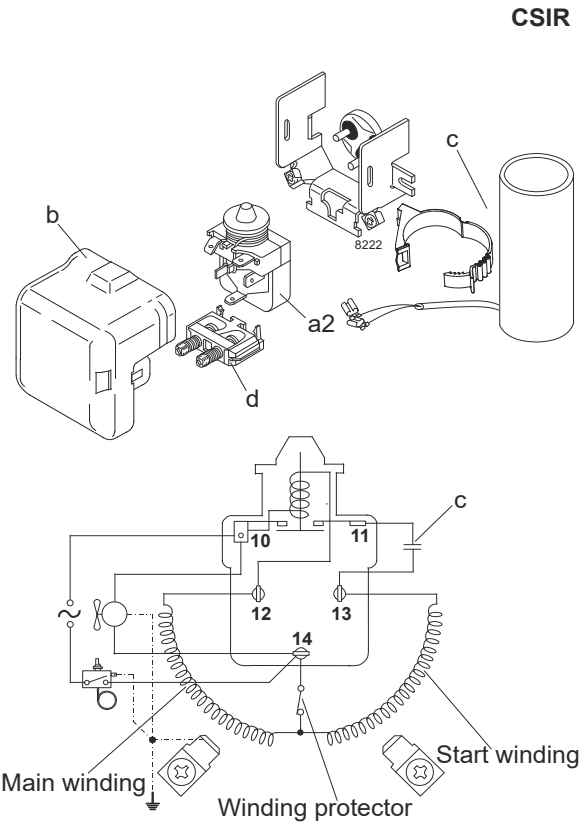

## Ambient/ machine room temperatures minimum /maximum

Ambient temperature range:	10 - 43°C / 50 - 110°F
Machine room temperature range:	10 - 48°C / 50 - 119°F
Compressor cooling:	fan 3m/s

## Operation Limits

## Operation pressure range

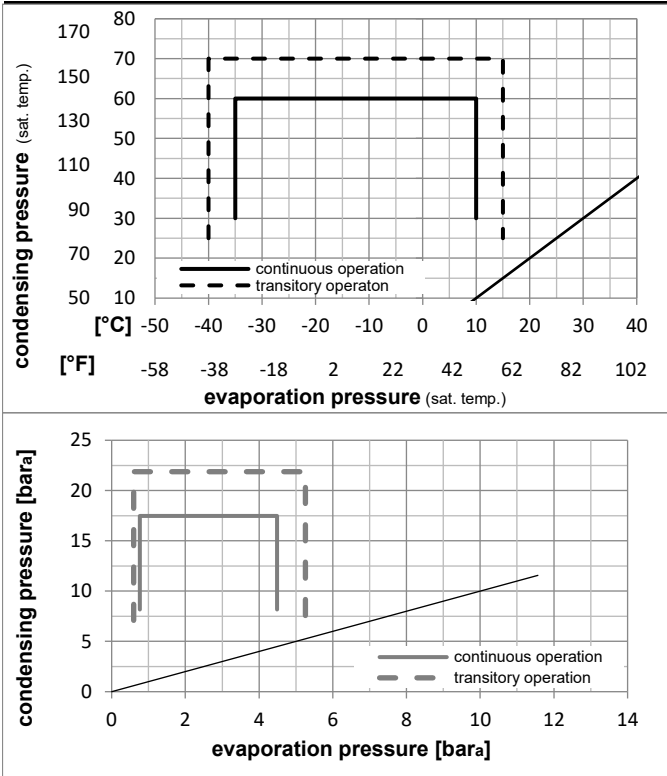

## Components

a2	relay	117U6020
c	start capacitor (240μF)	117U5023
d	cord relief	103N1004
b	plastic cover	103N2008

### Model

Designation	<b>SC12G</b>	<b>115V/60Hz</b>	<b>Conf. 2</b>	Sales code:	<b>104G7250</b>
-------------	--------------	------------------	----------------	-------------	-----------------

### Optimization + standard conditions

R513A, 115V/60Hz, CSIR, fan 3m/s, UL

	Evaporating pressure (saturation temperature)				Cooling capacity			COP	EER	P1	Power consumption			ASHRAE
	pe	pc	RGT	Tliq	[W]	[Btu/h]	[kcal/h]				Current consumption	Ref. mass flow		
	[°C]	[°F]	[°C]	[°F]	[W]	[Btu/h]	[kcal/h]	[W/W]	[Btu/Wh]	[kcal/Wh]	[W]	[A]	[kg/h]	
	-23	54	32	32	320,8	1095	276,1	1,05	3,57	0,90	306,8	4,22	6,90	ASHRAE LBP
	-10	130	90	90										
	-7	54	35	46	755,0	2578	649,8	1,58	5,41	1,36	477,0	5,34	18,49	ASHRAE MBP
	20	130	95	115										
	7,2	54	35	46	1407,3	4806	1211,2	2,25	7,69	1,94	625,4	6,32	34,96	ASHRAE HBP
	45	130	95	115										
	-35	40	20	40	162,0	553	139,4	0,77	2,62	0,66	211,5	3,59	4,01	EN12900 LBP
	-31	104	68	104										
	-10	45	20	45	668,7	2284	575,5	1,58	5,41	1,36	422,4	4,98	17,72	EN12900 MBP
	14	113	68	113										
	5	50	20	50	1180,5	4032	1015,9	2,03	6,94	1,75	581,3	6,03	33,85	EN12900 HBP
	41	122	68	122										

### Performance tables

R513A, 115V/60Hz, CSIR, fan 3m/s, UL

	pe		Cooling capacity			COP	EER	P1	I	m	
	[°C]	[°F]	[W]	[Btu/h]	[kcal/h]						
[°C / °F]	-35	-31	136,0	465	117,1	0,67	2,27	0,57	204,5	3,55	3,30
cond. pressure	-23	-10	333,3	1138	286,8	1,09	3,74	0,94	304,4	4,21	8,13
pc= 45/113	-15	5	541,5	1849	466,0	1,43	4,90	1,23	377,7	4,69	13,27
return gas temp.	-9	15	718,5	2454	618,3	1,68	5,74	1,45	427,3	5,02	17,67
RGT= 32/90	0	32	1100,8	3760	947,4	2,15	7,33	1,85	512,7	5,58	27,30
liquid temp	4,4	40	1320,5	4510	1136,4	2,39	8,15	2,05	553,2	5,85	32,91
Tliq= 45/113	10	50	1634,7	5583	1406,8	2,71	9,24	2,33	604,0	6,18	41,04
[°C / °F]	-35	-31	86,2	294	74,2	0,44	1,52	0,38	193,9	3,48	2,35
cond. pressure	-23	-10	249,6	853	214,8	0,81	2,78	0,70	307,1	4,22	6,84
pc= 55/131	-15	5	426,8	1458	367,3	1,09	3,72	0,94	391,5	4,78	11,76
return gas temp	-9	15	579,8	1980	499,0	1,29	4,41	1,11	449,2	5,16	16,04
RGT= 32/90	0	32	915,6	3127	788,0	1,67	5,69	1,43	549,6	5,82	25,57
liquid temp	4,4	40	1110,8	3794	956,0	1,86	6,35	1,60	597,8	6,14	31,19
Tliq= 55/131	10	50	1392,1	4754	1198,0	2,11	7,22	1,82	658,7	6,54	39,41



# SC Compressors







# SC Compressors

## Service/Repair – R290



8545



Secop accepts no responsibility for possible errors in catalogs, brochures, and other printed material. Secop reserves the right to alter its products without notice. This also applies to products already on order provided that such alterations can be made without subsequent changes being necessary to specifications already agreed. All trademarks in this material are the property of the respective companies. Secop and the Secop logotype are trademarks of Secop GmbH. All rights reserved. [www.secop.com](http://www.secop.com)