

Single Pack KLF7.7CNH 115-127V 60Hz CSIR

Single pack code number: **195B4727**

Position	Title	Code	Amount
1	Compressor KLF7.7CNH	106H3812	1
2	KL accessories	103N1060	1
3	Starting capacitor (240 μ F 125V, 6.3mm)	117U5002	1
4	Starting relay (QLZ-17.3A, overload protector T1141/L6)	117U7078	1
5	Bolt joint for one compressor M6 \varnothing 16mm	118-1917	1

Secop GmbH • Lise-Meitner-Straße 29 • 24941 Flensburg, Germany • Tel: +49 461 4941 0 • www.secop.com

Secop accepts no responsibility for possible errors in catalogs, brochures, and other printed material. Secop reserves the right to alter its products without notice. This also applies to products already on order provided that such alterations can be made without subsequent changes being necessary to specifications already agreed. All trademarks in this material are the property of the respective companies. Secop and the Secop logotype are trademarks of Secop GmbH. All rights reserved.

Model

Designation	KLF7.7CNH	115-127V/60Hz 1~	Sales code:	106H3812
-------------	------------------	------------------	-------------	-----------------

Compressor design

Oil type	Polyolester	Refrigerant(s)	R290
Oil viscosity	19,2cSt	Displacement	7,7cm ³ / 0,47cu.in
Oil quantity	162cm ³ / 5,5fl.oz	Compressors on pallet	100
Refr. charge - tech. limit	200g / 7,1oz		
Free gas volume comp.	1575cm ³ / 53,3fl.oz		
Weight	9,7kg / 21,4lbs		
Motor protection	external		
Winding resistance main	1,4Ω (at 25°C)		
Winding resistance aux	5,9Ω (at 25°C)		
Max. winding temp.	125°C / 257°F		
Max. discharge temp.	130°C / 266°F		



General - Configurations with KLF7.7CNH

	Conf. 1
Motorconfiguration	CSIR
Power supply (nominal)	115-127V/60Hz
Number of phases	1
Voltage range	95-140V
Approvals	UL
Starting torque	HST
Note	Electrical equipment is included and pre-assembled to compressor.

Applications with KLF7.7CNH

	Conf. 1
Refrigerant	R290
Application	LBP+MBP
System cooling	fan 3m/s
Hot gas defrost	OK
Long interval pull down	OK

Electrical data - Configurations with KLF7.7CNH

	Conf. 1
Starting device type	relay
Run capacitor	-/-
Start capacitor	240μF
LRA (locked rotor amps / 4s/ U(N))	35,6A
RLA (rated load amps / 1s/ U(N))	4,9A
Cut in current (U(N))	

Model

Designation	KLF7.7CNH	115-127V/60Hz 1~	Sales code:	106H3812
-------------	------------------	------------------	-------------	-----------------

Compressor dimensions

Housing	A Height	182mm / 7,17in
	B Height	175mm / 6,89in
	C Length shell	198mm / 7,8in
	D Length w. cover	238mm / 9,37in
	E Width	160mm / 6,3in

Connectors		Suction	Discharge	Process
		X	Y	Z
Diameter	[mm]	øi 8,11-8,29	øi 6,41-6,59	øi 6,41-6,59
(i:inside, o:outside)	[in]	øi 0,32-0,33	øi 0,25-0,26	øi 0,25-0,26
Material		copper	copper	copper
Horizontal angle	±2°	35°	13°	0°
Vertical angle	±2°	30°	40°	145°
Position l/h/w	[mm]	119/73/59	117/107/66	-88/101/71
	[in]	4,7/2,9/2,3	4,6/4,2/2,6	-3,5/4/2,8
Straight tube l.	[mm]	14	14	14
	[in]	0,5	0,5	0,5

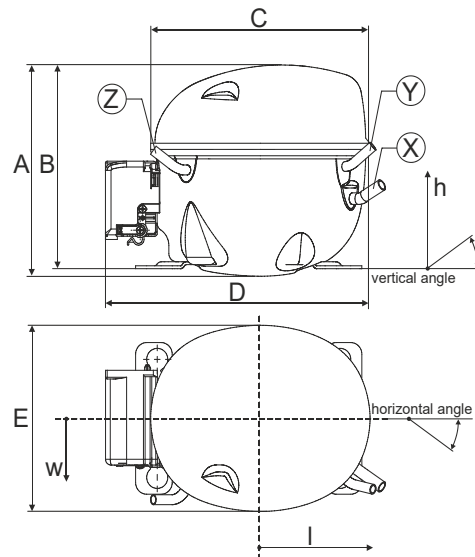

Compressor fixation

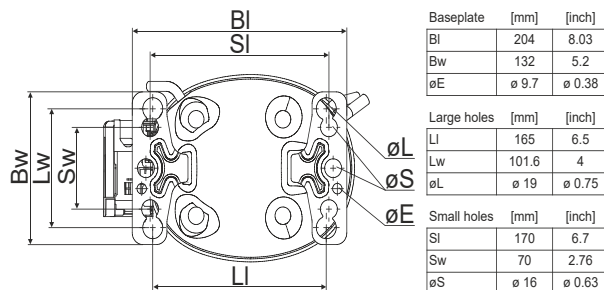

Bolt joint

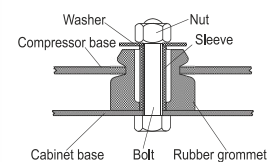

Snap-on

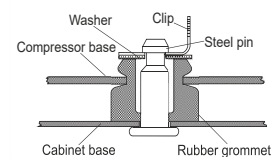

Mounting accessories	one comp.	multi pack
Bolt joint M6 ø16mm	118-1917	118-1918
Bolt joint ø1/4" ø16mm	118-1946	
Bolt joint ø1/4" ø19mm	118-1949	
Snap-on ø7,3 ø16mm	118-1947	118-1919

Application notes

Provision for PE Grounding is located at the PE Stamp on the compressor
Compressor comes on a wooden pallet

Model

Designation	KLF7.7CNH	115-127V/60Hz	Conf. 1	Sales code:	106H3812
-------------	------------------	----------------------	----------------	-------------	-----------------

Configuration

Motorconfiguration	CSIR
Power supply (nominal)	115-127V/60Hz 1~
Refrigerant	R290
Application	LBP+MBP
Voltage range	95-140V
Starting torque	HST
Approvals	UL

Electrical accessories / wiring diagram

CSIR



Ambient/ machine room temperatures minimum /maximum

Ambient temperature range:	10 - 43°C / 50 - 110°F
Machine room temperature range:	10 - 48°C / 50 - 119°F
Compressor cooling:	fan 3m/s



Operation pressure range



Components (already pre-assembled)

a5	current relay (T1141/L6-S6)	117U7078
c	start capacitor (240µF)	117U5002
b, d	cover + clamp + screws(5VA) in bag	103N1060

Alternative comp. (already pre-assembled)

b, d	100x cover + clamp + screws(5VA)	103N2060
b, d	cover + clamp + screws(5VA-compl.)	103N0600

Model

Designation **KLF7.7CNH** **115-127V/60Hz** Conf. 1 Sales code: **106H3812**

Optimization + standard conditions

R290, 115V/60Hz, CSIR, fan 3m/s, UL

	Evaporating pressure (saturation temperature)				Cooling capacity			COP	EER	Power consumption			ASHRAE	
	pe	pc	RGT	Tliq	[W]	[Btu/h]	[kcal/h]			P1	I	m		
	[°C]	[°C]	[°C]	[°C]				[W/W]	[Btu/Wh]	[kcal/Wh]	[W]	[A]	[kg/h]	
	-23	54	32	32	475,1	1622	408,9	1,62	5,53	1,39	293,6	3,44	4,81	ASHRAE LBP
	[°F]													
	-10	130	90	90										
	-25	55	32	55	356,6	1218	306,9	1,26	4,32	1,09	282,1	3,36	4,44	cecomaf LBP
	[°F]													
	-13	131	90	131										
	-35	40	20	40	267,4	913	230,1	1,23	4,20	1,06	217,4	2,94	3,05	EN12900 LBP
	[°F]													
	-31	104	68	104										
	-7	54	35	46	842,2	2876	724,8	2,06	7,02	1,77	409,7	4,31	9,61	ASHRAE MBP
	[°F]													
	20	130	95	115										
	-10	55	32	55	668,0	2281	574,9	1,72	5,86	1,48	389,3	4,15	8,45	cecomaf MBP
	[°F]													
	14	131	90	131										
	-10	45	20	45	750,4	2563	645,8	2,08	7,12	1,79	359,9	3,92	9,21	EN12900 MBP
	[°F]													
	14	113	68	113										

Performance tables

R290, 115V/60Hz, CSIR, fan 3m/s, UL

	pe		Cooling capacity			COP	EER	P1	I	m	
	[°C]	[°F]	[W]	[Btu/h]	[kcal/h]						
[°C / °F]	-40	-40	203,2	694	174,9	1,03	3,52	0,89	197,3	2,84	2,27
cond. pressure	-34	-30	269,8	921	232,2	1,20	4,10	1,03	224,9	2,98	3,02
pc= 45/113	-23	-10	453,5	1549	390,3	1,58	5,41	1,36	286,6	3,38	5,12
return gas temp.	-15	5	643,1	2196	553,5	1,93	6,59	1,66	333,5	3,72	7,32
RGT= 32/90	-4	25	977,1	3337	840,9	2,51	8,58	2,16	388,9	4,14	11,27
liquid temp	0	32	1118,5	3820	962,6	2,76	9,44	2,38	404,7	4,27	12,97
Tliq= 45/113	7,2	45	1417,8	4842	1220,2	3,32	11,34	2,86	427,0	4,45	16,66
[°C / °F]	-40	-40	175,9	601	151,4	0,95	3,25	0,82	185,0	2,76	2,17
cond. pressure	-34	-30	229,9	785	197,9	1,05	3,60	0,91	218,3	2,94	2,84
pc= 55/131	-23	-10	384,1	1312	330,5	1,31	4,46	1,12	294,0	3,44	4,79
return gas temp	-15	5	547,4	1869	471,1	1,55	5,28	1,33	354,0	3,88	6,88
RGT= 32/90	-4	25	840,9	2872	723,7	1,95	6,68	1,68	430,2	4,48	10,73
liquid temp	0	32	966,6	3301	831,9	2,13	7,27	1,83	454,2	4,67	12,42
Tliq= 55/131	7,2	45	1235,0	4218	1062,8	2,51	8,56	2,16	492,9	4,99	16,09



KL Compressors



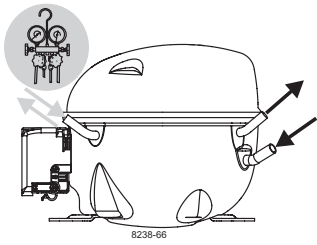

KL Compressors



Service/Repair – R290

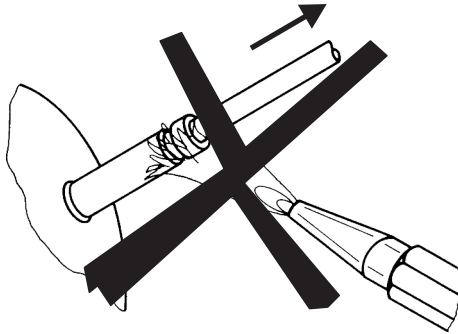

8545

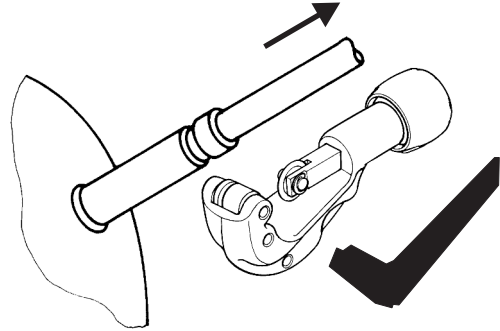

Secop accepts no responsibility for possible errors in catalogs, brochures, and other printed material. Secop reserves the right to alter its products without notice. This also applies to products already on order provided that such alterations can be made without subsequent changes being necessary to specifications already agreed. All trademarks in this material are the property of the respective companies. Secop and the Secop logotype are trademarks of Secop GmbH. All rights reserved. www.secop.com